

Table of Contents

SECTION 1 - SHEAVE NOMENCLATURE	2
SECTION 2 - BORED-TO-SIZE SHEAVES	
AK	3
2AK	4
BK	5
2BK	6
SECTION 3 - H BUSHING SHEAVES	
AK	7
2AK	8
BK	9
2BK	10
SECTION 4 - QD SHEAVES	
A/B	11
C	15
3V	19
5V	22
8V	26
SECTION 5 - LIGHT DUTY ADJUSTMENT SHEAVES	
1VL LIGHT DUTY ADJUSTABLE	28
AL LIGHT DUTY	28
SECTION 6 - VARIABLE PITCH SHEAVES	
1VP	29
2VP	29
SECTION 7 - BUSHINGS	
H AND QD®	30
TAPER-LOCK®	32
DOUBLE SPLIT TAPER	35
QD BUSHING/SHEAVE INSTALLATION	37
PRODUCT SPECIFICATIONS	38
SECTION 8 - SYNCHRONOUS TIMING PULLEYS	
STOCK BORE (XL, L, H, HTD)	40
QD® (L, H)	45
TAPER-LOCK® (L, H)	48
HTD (5M, 8M, 14M)	50
SECTION 9 - V-BELTS	
POWER KING® (A, B, C, D, E)	55
POWER ACE® (3V, 5V, 8V)	58
POWER KING® COG (AX, BX, CX)	59
POWER ACE® COG (3VX, 5VX)	61
POWER KING® COMBO (B, C, D)	62
POWER ACE® COMBO (3V, 5V, 8V)	63
DOUBLE (AA, BB, CC)	64
DURAFLEX GL® FHP (3L, 4L, 5L)	65
SECTION 10 - TIMING BELTS	
SYNCHRO-LINK® (XL, L, H)	67
SYNCHRO-LINK® METRIC (5M, 8M, 14M)	74
METRIC CONVERSION CHART	77
INCH-DECIMAL-MM CONVERSION CHART	80

QD is a registered trademark of Emerson Electric
 Taper-Lock and TL are registered trademarks of Reliance Electric
 Power King is a registered trademark of Bando USA
 Power Ace is a registered trademark of Bando USA
 Duraflex GL is a registered trademark of Bando USA
 Syncho-Link is a registered trademark of Bando USA
 IDC SELECT is a registered trademark of Independent Distributors Cooperative – USA

A-B QD Sheaves

2B 80 SK

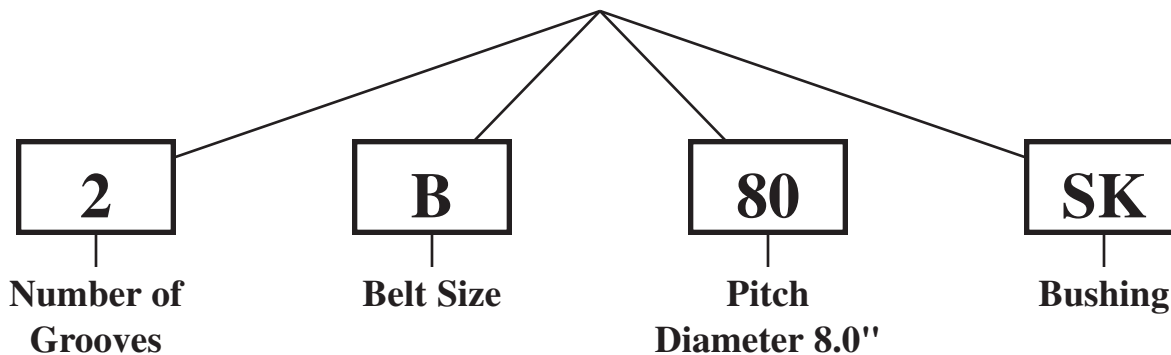

C QD Sheaves

6C 440 J

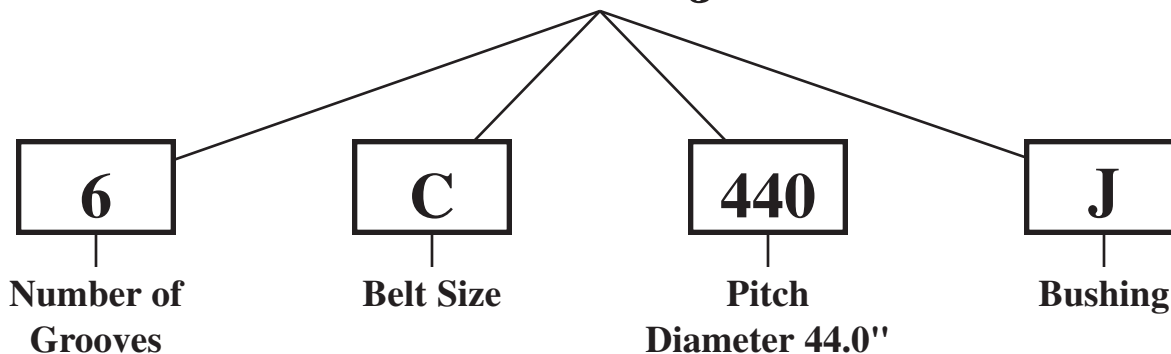

3V, 5V & 8V QD Sheaves

10-8V 1320 J

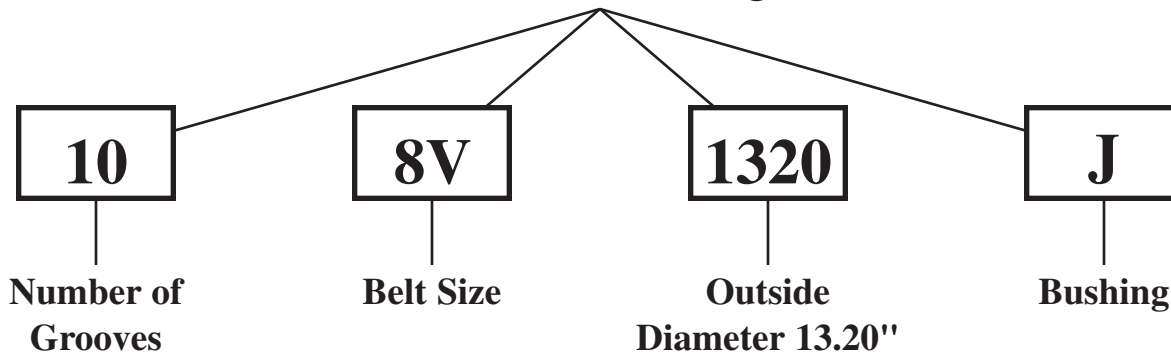

BORED-TO-SIZE SHEAVES AK

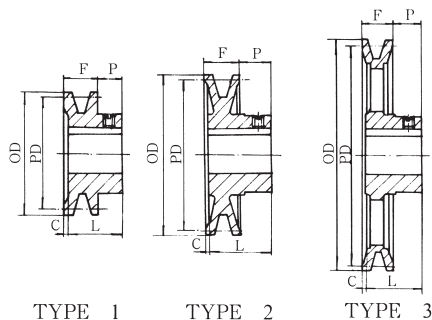

Single Groove Sheaves for “3L” “4L” & “A” Belts

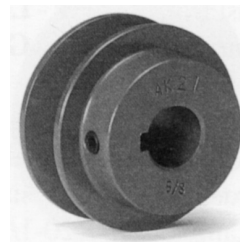

Part No.	Diameters (in.)		Type	Dimensions (in.)				Stock Bores (in.)	
	O.D.	Pitch		F	L	P	C		
AK17	1.75	1.16	1.50	1	2 ¹ / ₃₂	1 ⁵ / ₁₆	7 ¹ / ₁₆	5 ³ / ₃₂	1/2, 5/8
AK20	2.00	1.46	1.80	1	2 ¹ / ₃₂	1 ⁵ / ₁₆	7 ¹ / ₁₆	5 ³ / ₃₂	1/2, 5/8, 3/4
AK21	2.10	1.56	1.90	1	2 ¹ / ₃₂	1 ⁵ / ₁₆	7 ¹ / ₁₆	5 ³ / ₃₂	1/2, 5/8, 3/4
AK22	2.20	1.66	2.00	1	2 ¹ / ₃₂	1 ⁵ / ₁₆	7 ¹ / ₁₆	5 ³ / ₃₂	1/2, 5/8, 3/4
AK23	2.30	1.76	2.10	1	2 ¹ / ₃₂	1 ⁵ / ₁₆	7 ¹ / ₁₆	5 ³ / ₃₂	1/2, 5/8, 3/4, 7/8
AK25	2.50	1.96	2.30	2	2 ¹ / ₃₂	1 ⁵ / ₁₆	7 ¹ / ₁₆	5 ³ / ₃₂	1/2, 5/8, 3/4, 7/8, 1
AK26	2.60	2.06	2.40	2	2 ¹ / ₃₂	1 ⁵ / ₁₆	7 ¹ / ₁₆	5 ³ / ₃₂	1/2, 5/8, 3/4
AK27	2.70	2.16	2.50	2	2 ¹ / ₃₂	1 ⁵ / ₁₆	7 ¹ / ₁₆	5 ³ / ₃₂	1/2, 5/8, 3/4
AK28	2.80	2.26	2.60	2	2 ¹ / ₃₂	1 ⁵ / ₁₆	7 ¹ / ₁₆	5 ³ / ₃₂	1/2, 5/8, 3/4, 7/8, 1
AK30	3.05	2.46	2.80	2	2 ¹ / ₃₂	1 ⁵ / ₁₆	7 ¹ / ₁₆	5 ³ / ₃₂	1/2, 5/8, 3/4, 7/8, 1
AK32	3.25	2.66	3.00	2	2 ¹ / ₃₂	1 ⁵ / ₁₆	7 ¹ / ₁₆	5 ³ / ₃₂	1/2, 5/8, 3/4, 7/8, 1, 1 1/8
AK34	3.45	2.86	3.20	2	2 ¹ / ₃₂	1 ⁵ / ₁₆	7 ¹ / ₁₆	5 ³ / ₃₂	1/2, 5/8, 3/4, 7/8, 1, 1 1/8
AK39	3.75	3.16	3.50	2	3/4	1 5/32	1 5/32	1/16	1/2, 5/8, 3/4, 7/8, 1 5/16, 1, 1 1/8
AK41	3.95	3.36	3.70	2	3/4	1 5/32	1 5/32	1/16	1/2, 5/8, 3/4, 7/8, 1 5/16, 1
AK44	4.25	3.66	4.00	3	3/4	1 5/32	1 5/32	1/16	1/2, 5/8, 3/4, 7/8, 1 5/16, 1, 1 1/8
AK46	4.45	3.86	4.20	3	3/4	1 5/32	1 5/32	1/16	1/2, 5/8, 3/4, 7/8, 1 5/16, 1, 1 1/8
AK49	4.75	4.16	4.50	3	3/4	1 5/32	1 5/32	1/16	1/2, 5/8, 3/4, 7/8, 1 5/16, 1, 1 1/8
AK51	4.95	4.36	4.70	3	3/4	1 5/32	1 5/32	1/16	1/2, 5/8, 3/4, 7/8, 1, 1 1/8
AK54	5.25	4.66	5.00	3	3/4	1 5/32	1 5/32	1/16	1/2, 5/8, 3/4, 7/8, 1 5/16, 1, 1 1/8, 1 3/16
AK56	5.45	4.86	5.20	3	3/4	1 5/32	1 5/32	1/16	1/2, 5/8, 3/4, 7/8, 1 5/16, 1, 1 1/8, 1 3/16
AK59	5.75	5.16	5.50	3	3/4	1 5/32	1 5/32	1/16	1/2, 5/8, 3/4, 7/8, 1 5/16, 1, 1 1/8, 1 3/16
AK61	5.95	5.36	5.70	3	3/4	1 5/32	1 5/32	1/16	1/2, 5/8, 3/4, 7/8, 1 5/16, 1, 1 1/8, 1 3/16
AK64	6.25	5.66	6.00	3	3/4	1 5/32	1 5/32	1/16	1/2, 5/8, 3/4, 7/8, 1 5/16, 1, 1 1/8, 1 3/16
AK66	6.45	5.86	6.20	3	3/4	1 5/32	1 5/32	1/16	1/2, 5/8, 3/4, 1, 1 1/8
AK69	6.75	6.16	6.50	3	3/4	1 15/32	23/32	0	3/4, 1, 1 1/8
AK71	6.95	6.36	6.70	3	3/4	1 15/32	23/32	0	1/2, 5/8, 3/4, 1, 1 1/8, 1 7/16
AK74	7.25	6.66	7.00	3	3/4	1 15/32	23/32	0	1/2, 5/8, 3/4, 1 5/16, 1, 1 1/8, 1 3/16, 1 1/4, 1 7/16
AK79	7.75	7.16	7.50	3	3/4	1 15/32	23/32	0	3/4, 1, 1 1/8, 1 7/16
AK84	8.25	7.66	8.00	3	3/4	1 15/32	23/32	0	1/2, 5/8, 3/4, 1 5/16, 1, 1 3/16, 1 7/16
AK89	8.75	8.16	8.50	3	3/4	1 15/32	23/32	0	3/4, 1, 1 1/8, 1 7/16
AK94	9.25	8.66	9.00	3	3/4	1 15/32	23/32	0	1/2, 5/8, 3/4, 1 5/16, 1, 1 3/16, 1 1/4, 1 7/16
AK99	9.75	9.16	9.50	3	3/4	1 15/32	23/32	0	3/4, 1, 1 7/16
AK104	10.25	9.66	10.00	3	3/4	1 15/32	23/32	0	5/8, 3/4, 1, 1 3/16, 1 1/4, 1 3/8, 1 7/16
AK109	10.75	10.16	10.50	3	3/4	1 15/32	23/32	0	3/4, 1, 1 3/8, 1 7/16
AK114	11.25	10.66	11.00	3	3/4	1 15/32	23/32	0	3/4, 1, 1 3/16, 1 7/16
AK124	12.25	11.66	12.00	3	3/4	1 15/32	23/32	0	5/8, 3/4, 1, 1 3/16, 1 1/4, 1 7/16
AK134	13.25	12.66	13.00	3	3/4	1 15/32	23/32	0	3/4, 1, 1 3/16, 1 3/8, 1 7/16
AK144	14.25	13.66	14.00	3	3/4	1 15/32	23/32	0	3/4, 1, 1 3/16, 1 7/16
AK154	15.25	14.66	15.00	3	3/4	1 15/32	23/32	0	3/4, 1, 1 3/16, 1 3/8, 1 7/16
AK184	18.25	17.66	18.00	3	3/4	1 15/32	23/32	0	3/4, 1, 1 3/16, 1 7/16

Standard Keyseats	
Bore-Range	Keyseat
1/2	None
5/8 - 7/8	3/16 x 3/32
1 5/16 - 1 1/4	1/4 x 1/8
1 5/16 - 1 3/8	1/4 x 5/32
1 7/16 - 1 1/4	3/8 x 3/16

AK Sheaves are precision machined from gray cast iron, statically balanced, painted with baked enamel finish and individually packaged. Sheaves are furnished with standard keyways & set screws.

BORED-TO-SIZE SHEAVES 2AK

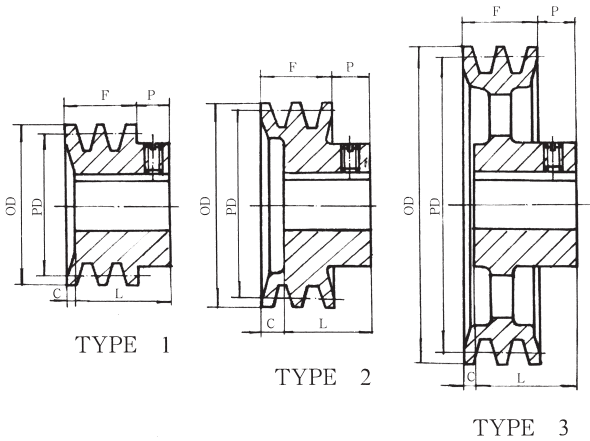

Two Groove Sheaves For "3L" "4L" & "A" Belts

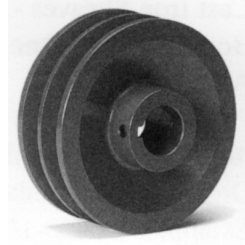

Part No.	Diameters (in.)		Type	Dimensions (in.)				Stock Bores (in.)	
	O.D.	Pitch		F	L	P	C		
		"3L"							"4L+A"
2AK20	2.00	1.46	1.80	1	1 3/8	1 21/32	15/32	3/16	1/2, 5/8, 3/4, 7/8
2AK21	2.15	1.56	1.90	1	1 3/8	1 21/32	15/32	3/16	1/2, 5/8, 3/4
2AK22	2.25	1.66	2.00	1	1 3/8	1 21/32	15/32	3/16	1/2, 5/8, 3/4, 7/8
2AK23	2.35	1.76	2.10	1	1 3/8	1 21/32	15/32	3/16	5/8, 3/4, 7/8, 1
2AK25	2.55	1.96	2.30	1	1 3/8	1 21/32	15/32	3/16	5/8, 3/4, 7/8, 1
2AK26	2.65	2.06	2.40	1	1 3/8	1 21/32	15/32	3/16	5/8, 3/4, 7/8, 1
2AK27	2.75	2.16	2.50	1	1 3/8	1 21/32	15/32	3/16	5/8, 3/4, 7/8, 1
2AK28	2.85	2.26	2.60	1	1 3/8	1 21/32	15/32	3/16	5/8, 3/4, 7/8, 1
2AK30	3.05	2.46	2.80	1	1 3/8	1 21/32	15/32	3/16	1/2, 5/8, 3/4, 7/8, 1, 1 1/8
2AK32	3.25	2.66	3.00	1	1 3/8	1 21/32	15/32	3/16	1/2, 5/8, 3/4, 7/8, 1, 1 1/8
2AK34	3.45	2.86	3.20	1	1 3/8	1 21/32	15/32	3/16	1/2, 5/8, 3/4, 7/8, 1, 1 1/8
2AK39	3.75	3.16	3.50	2	1 3/8	1 11/32	15/32	1/2	1/2, 5/8, 3/4, 7/8, 1, 1 1/8
2AK41	3.95	3.36	3.70	2	1 3/8	1 11/32	15/32	1/2	5/8, 3/4, 7/8, 1, 1 1/8
2AK44	4.25	3.66	4.00	2	1 3/8	1 11/32	15/32	1/2	5/8, 3/4, 7/8, 1, 1 1/8
2AK46	4.45	3.86	4.20	2	1 3/8	1 11/32	15/32	1/2	7/8, 1, 1 1/8
2AK49	4.75	4.16	4.50	2	1 3/8	1 11/32	15/32	1/2	3/4, 7/8, 1, 1 1/8, 1 3/8
2AK51	4.95	4.36	4.70	2	1 3/8	1 11/32	15/32	1/2	3/4, 7/8, 1, 1 1/8, 1 3/8
2AK54	5.25	4.66	5.00	3	1 3/8	1 11/32	15/32	1/2	5/8, 3/4, 7/8, 1, 1 1/8, 1 3/8
2AK56	5.45	4.86	5.20	3	1 3/8	1 11/32	15/32	1/2	5/8, 3/4, 7/8, 1, 1 1/8, 1 3/8
2AK59	5.75	5.16	5.50	3	1 3/8	1 11/32	15/32	1/2	1, 1 1/8, 1 3/8
2AK61	5.95	5.36	5.70	3	1 3/8	1 11/32	15/32	1/2	3/4, 7/8, 1, 1 1/8, 1 3/8
2AK64	6.25	5.66	6.00	3	1 3/8	1 19/32	11/32	1/8	3/4, 1, 1 1/8, 1 3/16, 1 3/8, 1 7/16
2AK74	7.25	6.66	7.00	3	1 3/8	1 19/32	11/32	1/8	3/4, 1, 1 1/8, 1 3/16, 1 3/8, 1 7/16
2AK84	8.25	7.66	8.00	3	1 3/8	1 19/32	11/32	1/8	3/4, 15/16, 1, 1 1/8, 1 3/16, 1 3/8, 1 7/16
2AK94	9.25	8.66	9.00	3	1 3/8	1 19/32	11/32	1/8	3/4, 1, 1 1/8, 1 3/16, 1 3/8, 1 7/16
2AK104	10.25	9.66	10.00	3	1 3/8	1 19/32	11/32	1/8	3/4, 15/16, 1, 1 7/16
2AK114	11.25	10.66	11.00	3	1 3/8	1 19/32	11/32	1/8	3/4, 1, 1 3/16, 1 3/8, 1 7/16
2AK124	12.25	11.66	12.00	3	1 3/8	1 19/32	11/32	1/8	3/4, 1, 1 3/16, 1 7/16
2AK134	13.25	12.66	13.00	3	1 3/8	1 19/32	11/32	1/8	1 3/16, 1 7/16
2AK144	14.25	13.66	14.00	3	1 3/8	1 19/32	11/32	1/8	1, 1 7/16
2AK154	15.25	14.66	15.00	3	1 3/8	1 19/32	11/32	1/8	1 3/16, 1 7/16
2AK184	18.25	17.66	18.00	3	1 3/8	1 19/32	11/32	1/8	1 3/16, 1 7/16

Standard Keyseats	
Bore-Range	Keyseat
1/2	None
5/8 - 7/8	3/16 x 3/32
15/16 - 1 1/4	1/4 x 1/8
1 5/16 - 1 3/8	5/16 x 5/32
1 7/16 - 1 1/4	3/8 x 3/16

2AK Sheaves are precision machined from gray cast iron, statically balanced, painted with baked enamel finish and individually packaged. Sheaves are furnished with standard keyways & set screws.

BORED-TO-SIZE SHEAVES BK

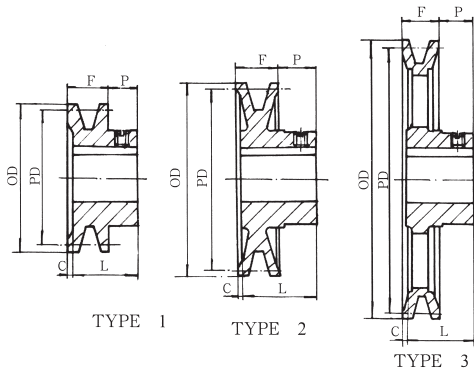

Single Groove Sheaves for "4L" "5L" & "B" Belts



Part No.	Diameters (in.)		Type	Dimensions (in.)				Stock Bores (in.)	
	O.D.	Pitch		F	L	P	C		
BK24	2.40	1.80	2.20	1	13/16	1 1/16	13/32	5/32	1/2, 5/8, 3/4, 7/8
BK25	2.50	1.90	2.30	1	13/16	1 1/16	13/32	5/32	1/2, 5/8, 3/4, 7/8, 1
BK26	2.60	2.00	2.40	1	13/16	1 1/16	13/32	5/32	1/2, 5/8, 3/4, 7/8
BK27	2.70	2.10	2.50	2	13/16	1 1/16	13/32	5/32	1/2, 5/8, 3/4, 7/8, 1
BK28	2.95	2.20	2.60	2	13/16	1 1/16	13/32	5/32	1/2, 5/8, 3/4, 7/8, 1, 1 1/8
BK30	3.15	2.40	2.80	2	13/16	1 1/16	13/32	5/32	1/2, 5/8, 3/4, 7/8, 1
BK32	3.35	2.60	3.00	2	13/16	1 1/16	13/32	5/32	1/2, 5/8, 3/4, 7/8
BK34	3.55	2.80	3.20	2	7/8	1 5/32	13/32	1/8	1/2, 5/8, 3/4, 7/8, 1, 1 1/8
BK36	3.75	3.00	3.40	2	7/8	1 5/32	13/32	1/8	1/2, 5/8, 3/4, 7/8, 1, 1 1/8
BK40	3.95	3.20	3.60	2	7/8	1 5/32	13/32	1/8	1/2, 5/8, 3/4, 7/8, 1, 1 1/8
BK45	4.25	3.50	3.90	2	7/8	1 5/32	13/32	1/8	1/2, 5/8, 3/4, 7/8, 1, 1 1/8
BK47	4.45	3.70	4.10	2	7/8	1 5/32	13/32	1/8	1/2, 5/8, 3/4, 7/8, 1, 1 1/8
BK50	4.75	4.00	4.40	3	7/8	1 5/32	13/32	1/8	1/2, 5/8, 3/4, 7/8, 1, 1 1/8
BK52	4.95	4.20	4.60	3	7/8	1 5/32	13/32	1/8	1/2, 5/8, 3/4, 7/8, 1, 1 1/8
BK55	5.25	4.50	4.90	3	7/8	1 5/32	13/32	1/8	1/2, 5/8, 3/4, 7/8, 1, 1 1/8, 1 3/16
BK57	5.45	4.70	5.10	3	7/8	1 5/32	13/32	1/8	5/8, 3/4, 7/8, 1 5/16, 1, 1 1/8
BK60	5.75	5.00	5.40	3	7/8	1 5/32	13/32	1/8	1/2, 5/8, 3/4, 7/8, 1, 1 1/8, 1 3/16
BK62	5.95	5.20	5.60	3	7/8	1 5/32	13/32	1/8	1/2, 5/8, 3/4, 7/8, 1 5/16, 1, 1 1/8, 1 3/16
BK65	6.25	5.50	5.90	3	7/8	1 5/32	13/32	1/8	5/8, 3/4, 1, 1 1/8
BK67	6.45	5.70	6.10	3	7/8	1 5/32	13/32	1/8	5/8, 3/4, 1, 1 1/8
BK70	6.75	6.00	6.40	3	7/8	1 15/32	2 1/32	1/16	5/8, 3/4, 7/8, 1 5/16, 1, 1 1/8, 1 3/16, 1 7/16
BK72	6.95	6.20	6.60	3	7/8	1 15/32	2 1/32	1/16	3/4, 1, 1 1/8, 1 3/8
BK75	7.25	6.50	6.90	3	7/8	1 15/32	2 1/32	1/16	3/4, 1, 1 1/8, 1 3/8
BK77	7.45	6.70	7.10	3	7/8	1 15/32	2 1/32	1/16	3/4, 1, 1 1/8, 1 3/8
BK80	7.75	7.00	7.40	3	7/8	1 15/32	2 1/32	1/16	5/8, 3/4, 7/8, 1, 1 1/8, 1 3/16, 1 1/4, 1 3/8, 1 7/16
BK85	8.25	7.50	7.90	3	7/8	1 15/32	2 1/32	1/16	3/4, 1, 1 1/8, 1 3/8, 1 7/16
BK90	8.75	8.00	8.40	3	7/8	1 15/32	2 1/32	1/16	3/4, 7/8, 1 5/16, 1, 1 1/8, 1 3/16, 1 3/8, 1 7/16
BK95	9.25	8.50	8.90	3	7/8	1 15/32	2 1/32	1/16	3/4, 1, 1 1/8, 1 3/8, 1 7/16
BK100	9.75	9.00	9.40	3	7/8	1 15/32	2 1/32	1/16	3/4, 7/8, 1 5/16, 1, 1 1/8, 1 3/16, 1 1/4, 1 3/8, 1 7/16
BK105	10.25	9.50	9.90	3	7/8	1 15/32	2 1/32	1/16	1, 1 3/8, 1 7/16
BK110	10.75	10.00	10.40	3	7/8	1 15/32	2 1/32	1/16	3/4, 1, 1 1/8, 1 3/16, 1 3/8, 1 7/16
BK115	11.25	10.50	10.90	3	7/8	1 15/32	2 1/32	1/16	1, 1 3/8, 1 7/16
BK120	11.75	11.00	11.40	3	7/8	1 15/32	2 1/32	1/16	3/4, 1, 1 3/16, 1 1/4, 1 3/8, 1 7/16
BK130	12.75	12.00	12.40	3	7/8	1 15/32	2 1/32	1/16	3/4, 1, 1 1/8, 1 3/16, 1 1/4, 1 7/16
BK140	13.75	13.00	13.40	3	7/8	1 15/32	2 1/32	1/16	3/4, 1, 1 3/16, 1 7/16
BK160	15.75	15.00	15.40	3	7/8	1 15/32	2 1/32	1/16	1, 1 1/8, 1 3/16, 1 1/4, 1 7/16
BK190	18.75	18.00	18.40	3	7/8	1 15/32	2 1/32	1/16	1, 1 3/16, 1 1/4, 1 7/16

Standard Keyseats	
Bore-Range	Keyseat
1/2	None
5/8 - 7/8	3/16 x 3/32
15/16 - 1 1/4	1/4 x 1/8
1 3/16 - 1 3/8	5/16 x 3/32
1 7/16 - 1 1/4	3/8 x 3/16

BK Sheaves are precision machined from gray cast iron, statically balanced, painted with baked enamel finish and individually packaged. Sheaves are furnished with standard keyways & set screws.

BORED-TO-SIZE SHEAVES 2BK

Two Groove Sheaves for "4L" "5L" "A" & "B" Belts

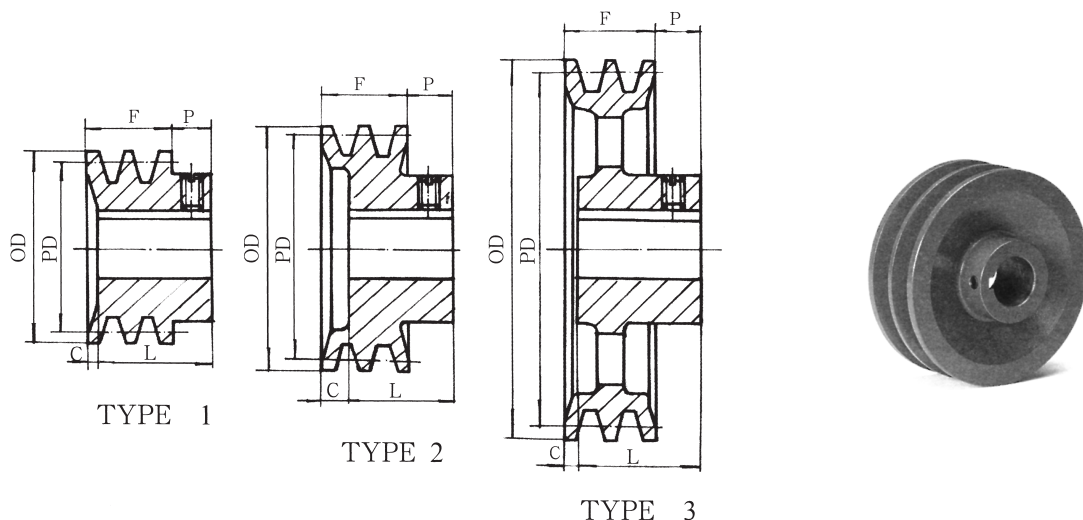

Part No.	Diameters (in.)			Type	Dimensions (in.)				Stock Bores (in.)
	O.D.	Pitch			F	L	P	C	
		"4L+A"	"5L+B"						
2BK25	2.50	1.90	2.30	1	1 3/4	1 31/32	15/32	1/4	1/2, 5/8, 3/4, 7/8
2BK27	2.70	2.10	2.50	1	1 3/4	1 31/32	15/32	1/4	1/2, 5/8, 3/4, 7/8, 1, 1 1/8
2BK28	2.95	2.20	2.60	1	1 3/4	1 31/32	15/32	1/4	1/2, 5/8, 3/4, 7/8, 1, 1 1/8
2BK30	3.15	2.40	2.80	1	1 3/4	1 31/32	15/32	1/4	1/2, 5/8, 3/4, 7/8, 1, 1 1/8, 1 3/8
2BK32	3.35	2.60	3.00	1	1 3/4	1 31/32	15/32	1/4	5/8, 3/4, 7/8, 1, 1 1/8
2BK34	3.55	2.80	3.20	1	1 3/4	1 31/32	15/32	1/4	5/8, 3/4, 7/8, 1, 1 1/8
2BK36	3.75	3.00	3.40	1	1 3/4	1 31/32	15/32	1/4	3/4, 7/8, 1, 1 1/8, 1 3/8
2BK40	3.95	3.20	3.60	2	1 3/4	1 15/32	15/32	3/4	5/8, 3/4, 7/8, 1, 1 1/8
2BK45	4.25	3.50	3.90	2	1 3/4	1 15/32	15/32	3/4	1, 1 1/8, 1 3/8
2BK47	4.45	3.70	4.10	2	1 3/4	1 15/32	15/32	3/4	7/8, 1, 1 1/8, 1 3/8
2BK50	4.75	4.00	4.40	2	1 3/4	1 15/32	15/32	3/4	3/4, 1, 1 1/8, 1 3/8
2BK52	4.95	4.20	4.60	2	1 3/4	1 15/32	15/32	3/4	5/8, 7/8, 1, 1 1/8, 1 3/8
2BK55	5.25	4.50	4.90	2	1 3/4	1 15/32	15/32	3/4	1 1/8, 1 3/8
2BK57	5.45	4.70	5.10	2	1 3/4	1 15/32	15/32	3/4	1, 1 1/8, 1 3/8
2BK60	5.75	5.00	5.40	3	1 3/4	1 15/32	15/32	3/4	3/4, 7/8, 1, 1 1/8, 1 3/8
2BK62	5.95	5.20	5.60	3	1 3/4	1 15/32	15/32	3/4	1, 1 1/8
2BK65	6.25	5.50	5.90	3	1 3/4	1 15/32	15/32	3/4	1, 1 1/8, 1 3/8
2BK67	6.45	5.70	6.10	3	1 3/4	1 15/32	15/32	3/4	1, 1 1/8, 1 3/8
2BK70	6.75	6.00	6.40	3	1 3/4	1 19/32	11/32	1/2	3/4, 1, 1 1/8, 1 3/16, 1 3/8, 1 7/16
2BK80	7.75	7.00	7.40	3	1 3/4	1 19/32	11/32	1/2	3/4, 1, 1 1/8, 1 3/16, 1 3/8, 1 7/16
2BK90	8.75	8.00	8.40	3	1 3/4	1 19/32	11/32	1/2	3/4, 1, 1 1/8, 1 3/16, 1 3/8, 1 7/16
2BK100	9.75	9.00	9.40	3	1 3/4	1 19/32	11/32	1/2	3/4, 1, 1 3/16, 1 3/8, 1 7/16
2BK110	10.75	10.00	10.40	3	1 3/4	1 19/32	11/32	1/2	1, 1 3/16, 1 7/16
2BK120	11.75	11.00	11.40	3	1 3/4	1 19/32	11/32	1/2	1, 1 3/16, 1 7/16
2BK130	12.75	12.00	12.40	3	1 3/4	1 19/32	11/32	1/2	1, 1 3/16, 1 7/16
2BK140	13.75	13.00	13.40	3	1 3/4	1 19/32	11/32	1/2	1, 1 3/16, 1 7/16
2BK160	15.75	15.00	15.40	3	1 3/4	1 19/32	11/32	1/2	1, 1 3/16, 1 7/16
2BK190	18.75	18.00	18.40	3	1 3/4	1 19/32	11/32	1/2	1 3/16, 1 1/4, 1 7/16

Standard Keyseats	
Bore-Range	Keyseat
1/2	None
5/8 - 7/8	3/16 x 3/32
15/16 - 1 1/4	1/4 x 1/8
1 5/16 - 1 3/8	5/16 x 5/32
1 7/16 - 1 1/4	3/8 x 3/16

2BK Sheaves are precision machined from gray cast iron, statically balanced, painted with baked enamel finish and individually packaged. Sheaves are furnished with standard keyways & set screws.

H BUSHING SHEAVES AK

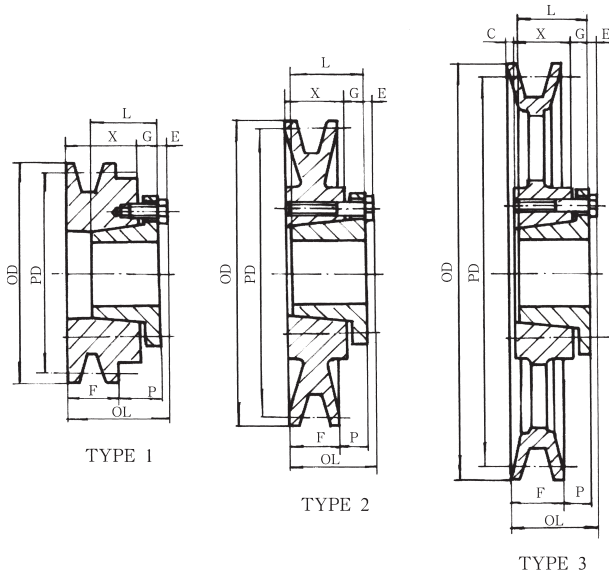

Single Groove Sheaves for "3L" "4L" & "A" Belts



For All Sheaves:

- F = 3/4
- L = 1 1/4
- G = 7/16
- E = 3/16

Stock H Bushings

Stock Bores	Keyseat
3/8	None
7/16	None
1/2	1/8 x 1/16
9/16	1/8 x 1/16
5/8	3/16 x 3/32
11/16	3/16 x 3/32
3/4	3/16 x 3/32
13/16	3/16 x 3/32
7/8	3/16 x 3/32
15/16	1/4 x 1/8
1	1/4 x 1/8
1 1/16	1/4 x 1/8
1 1/8	1/4 x 1/8
1 3/16	1/4 x 1/8
1 1/4	1/4 x 1/8
1 5/16	5/16 x 1/16*
1 3/8	5/16 x 1/16*
1 7/16	3/8 x 1/16*
1 1/2	3/8 x 1/16*

* Indicates shallow keyseat—keystock is supplied with bushing.

Part No.	Diameters (in.)		Type	Dimensions (in.)			
	O.D.	Pitch		O.L.	P	X	
		"3L"					"4L+A"
AK30H	3.05	2.46	2.80	1	1 13/16	7/8	1 3/16
AK32H	3.25	2.66	3.00	1	1 13/16	7/8	1 3/16
AK34H	3.45	2.86	3.20	2	1 1/2	9/16	7/8
AK39H	3.75	3.16	3.50	2	1 1/2	9/16	7/8
AK41H	3.95	3.36	3.70	2	1 1/2	9/16	7/8
AK44H	4.25	3.66	4.00	2	1 1/2	9/16	7/8
AK46H	4.45	3.86	4.20	2	1 1/2	9/16	7/8
AK49H	4.75	4.16	4.50	2	1 1/2	9/16	7/8
AK51H	4.95	4.36	4.70	2	1 1/2	9/16	7/8
AK54H	5.25	4.66	5.00	2	1 1/2	9/16	7/8
AK56H	5.45	4.86	5.20	2	1 1/2	9/16	7/8
AK59H	5.75	5.16	5.50	2	1 1/2	9/16	7/8
AK61H	5.95	5.36	5.70	3	1 1/2	9/16	7/8
AK64H	6.25	5.66	6.00	3	1 1/2	9/16	7/8
AK66H	6.45	5.86	6.20	3	1 1/2	9/16	7/8
AK69H	6.75	6.16	6.50	3	1 1/2	9/16	7/8
AK71H	6.95	6.36	6.70	3	1 1/2	9/16	7/8
AK74H	7.25	6.66	7.00	3	1 1/2	9/16	7/8
AK79H	7.75	7.16	7.50	3	1 1/2	9/16	7/8
AK84H	8.25	7.66	8.00	3	1 1/2	9/16	7/8
AK89H	8.75	8.16	8.50	3	1 1/2	9/16	7/8
AK94H	9.25	8.66	9.00	3	1 1/2	9/16	7/8
AK99H	9.75	9.16	9.50	3	1 1/2	9/16	7/8
AK104H	10.25	9.66	10.00	3	1 1/2	9/16	7/8
AK109H	10.75	10.16	10.50	3	1 1/2	9/16	7/8
AK114H	11.25	10.66	11.00	3	1 1/2	9/16	7/8
AK124H	12.25	11.66	12.00	3	1 1/2	9/16	7/8
AK134H	13.25	12.66	13.00	3	1 1/2	9/16	7/8
AK144H	14.25	13.66	14.00	3	1 1/2	9/16	7/8
AK154H	15.25	14.66	15.00	3	1 1/2	9/16	7/8
AK184H	18.25	17.66	18.00	3	1 1/2	9/16	7/8

AKH Sheaves are precision machined from gray cast iron, statically balanced, painted with baked enamel finish and individually packaged.

Millimeter Bores

Bore Range	Keyseat
10 mm	None
11 mm	None
14 mm	5 mm x 5 mm
15 mm	5 mm x 5 mm
16 mm	5 mm x 5 mm
18 mm	6 mm x 6 mm
19 mm	6 mm x 6 mm
20 mm	6 mm x 6 mm
22 mm	6 mm x 6 mm
24 mm	8 mm x 7 mm
25 mm	8 mm x 7 mm
28 mm	8 mm x 7 mm
30 mm	8 mm x 7 mm
32 mm	10 mm x 7 mm
35 mm	10 mm x 7 mm
38 mm	10 mm x 7 mm

H BUSHING SHEAVES 2AK

Two Groove Sheaves for "3L" "4L" & "A" Belts

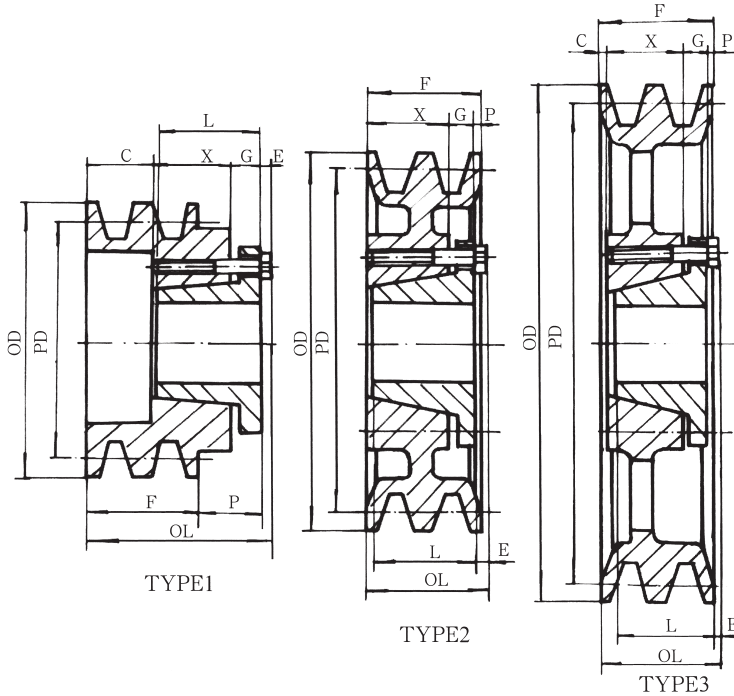

For All Sheaves:

- F = 1 3/4
- L = 1 1/4
- X = 7/8
- G = 7/16
- E = 3/16



Stock H Bushings

Stock Bores	Keyseat
3/8	None
7/16	None
1/2	1/8 x 1/16
9/16	1/8 x 1/16
5/8	3/16 x 3/32
11/16	3/16 x 3/32
3/4	3/16 x 3/32
13/16	3/16 x 3/32
7/8	3/16 x 3/32
15/16	1/4 x 1/8
1	1/4 x 1/8
1 1/16	1/4 x 1/8
1 1/8	1/4 x 1/8
1 3/16	1/4 x 1/8
1 1/4	1/4 x 1/8
1 5/16	5/16 x 1/16*
1 3/8	5/16 x 1/16*
1 7/16	3/8 x 1/16*
1 1/2	3/8 x 1/16*

* Indicates shallow keyseat—keystock is supplied with bushing.

Part No.	Diameters (in.)		Type	Dimensions (in.)			
	O.D.	Pitch		O.L.	P	C	
		"3L"					"4L+A"
2AK30H	3.05	2.46	2.80	1	2 7/16	7/8	15/16
2AK32H	3.25	2.66	3.00	1	2 7/16	7/8	15/16
2AK34H	3.45	2.86	3.20	1	2	7/16	1/2
2AK39H	3.75	3.16	3.50	1	2	7/16	1/2
2AK41H	3.95	3.36	3.70	2	1 1/2	1/16	-
2AK44H	4.25	3.66	4.00	2	1 1/2	1/16	-
2AK46H	4.45	3.86	4.20	2	1 1/2	1/16	-
2AK49H	4.75	4.16	4.50	2	1 1/2	1/16	-
2AK51H	4.95	4.36	4.70	2	1 1/2	1/16	-
2AK54H	5.25	4.66	5.00	2	1 1/2	1/16	-
2AK56H	5.45	4.86	5.20	2	1 1/2	1/16	-
2AK59H	5.75	5.16	5.50	3	1 1/2	1/16	-
2AK61H	5.95	5.36	5.70	3	1 1/2	1/16	-
2AK64H	6.25	5.66	6.00	3	1 1/2	1/16	-
2AK74H	7.25	6.66	7.00	3	1 1/2	1/16	-
2AK84H	8.25	7.66	8.00	3	1 1/2	1/16	-
2AK94H	9.25	8.66	9.00	3	1 1/2	1/16	-
2AK104H	10.25	9.66	10.00	3	1 1/2	1/16	-
2AK114H	11.25	10.66	11.00	3	1 1/2	1/16	-
2AK124H	12.25	11.66	12.00	3	1 1/2	1/16	-
2AK134H	13.25	12.66	13.00	3	1 1/2	1/16	-
2AK144H	14.25	13.66	14.00	3	1 1/2	1/16	-
2AK154H	15.25	14.66	15.00	3	1 1/2	1/16	-
2AK184H	18.25	17.66	18.00	3	1 1/2	1/16	-

2AKH Sheaves are precision machined from gray cast iron, statically balanced, painted with baked enamel finish and individually packaged.

Millimeter Bores

Bore Range	Keyseat
10 mm	None
11 mm	None
14 mm	5 mm x 5 mm
15 mm	5 mm x 5 mm
16 mm	5 mm x 5 mm
18 mm	6 mm x 6 mm
19 mm	6 mm x 6 mm
20 mm	6 mm x 6 mm
22 mm	6 mm x 6 mm
24 mm	8 mm x 7 mm
25 mm	8 mm x 7 mm
28 mm	8 mm x 7 mm
30 mm	8 mm x 7 mm
32 mm	10 mm x 7 mm
35 mm	10 mm x 7 mm
38 mm	10 mm x 7 mm

H BUSHING SHEAVES BK

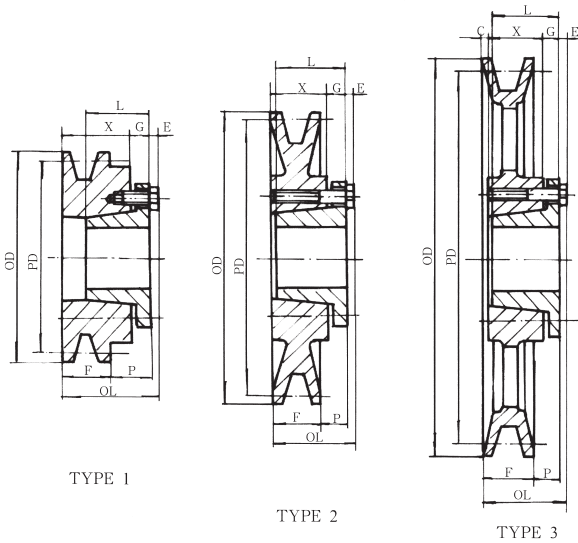

Single Groove Sheaves for "4L" "5L" "A" & "B" Belts



For All Sheaves:

- F = 7/8
- L = 1 1/4
- G = 7/16
- E = 3/16

Stock H Bushings

Stock Bores	Keyseat
3/8	None
7/16	None
1/2	1/8 x 1/16
9/16	1/8 x 1/16
5/8	3/16 x 3/32
11/16	3/16 x 3/32
3/4	3/16 x 3/32
13/16	3/16 x 3/32
7/8	3/16 x 3/32
15/16	1/4 x 1/8
1	1/4 x 1/8
1 1/16	1/4 x 1/8
1 1/8	1/4 x 1/8
1 3/16	1/4 x 1/8
1 1/4	1/4 x 1/8
1 5/16	5/16 x 1/16*
1 3/8	5/16 x 1/16*
1 7/16	3/8 x 1/16*
1 1/2	3/8 x 1/16*

* Indicates shallow keyseat—keystock is supplied with bushing.

Part No.	Diameters (in.)		Type	Dimensions (in.)				
	O.D.	Pitch		O.L.	P	C	X	
		"4L+A"						"5L+B"
BK30H	3.15	2.40	2.80	1	1 15/16	7/8	—	15/16
BK32H	3.35	2.60	3.00	1	1 15/16	7/8	—	15/16
BK34H	3.55	2.80	3.20	1	1 15/16	7/8	—	15/16
BK36H	3.75	3.00	3.40	2	1 1/2	7/16	—	7/8
BK40H	3.95	3.20	3.60	2	1 1/2	7/16	—	7/8
BK45H	4.25	3.50	3.90	2	1 1/2	7/16	—	7/8
BK47H	4.45	3.70	4.10	2	1 1/2	7/16	—	7/8
BK50H	4.75	4.00	4.40	2	1 1/2	7/16	—	7/8
BK52H	4.95	4.20	4.60	2	1 1/2	7/16	—	7/8
BK55H	5.25	4.50	4.90	2	1 1/2	7/16	—	7/8
BK57H	5.45	4.70	5.10	2	1 1/2	7/16	—	7/8
BK60H	5.75	5.00	5.40	2	1 1/2	7/16	—	7/8
BK62H	5.95	5.20	5.60	2	1 1/2	7/16	—	7/8
BK65H	6.25	5.50	5.90	2	1 1/2	7/16	—	7/8
BK67H	6.45	5.70	6.10	2	1 1/2	7/16	—	7/8
BK70H	6.75	6.00	6.40	3	1 9/16	1/2	1/16	7/8
BK72H	6.95	6.20	6.60	3	1 9/16	1/2	1/16	7/8
BK75H	7.25	6.50	6.90	3	1 9/16	1/2	1/16	7/8
BK77H	7.45	6.70	7.10	3	1 9/16	1/2	1/16	7/8
BK80H	7.75	7.00	7.40	3	1 9/16	1/2	1/16	7/8
BK85H	8.25	7.50	7.90	3	1 9/16	1/2	1/16	7/8
BK90H	8.75	8.00	8.40	3	1 9/16	1/2	1/16	7/8
BK95H	9.25	8.50	8.90	3	1 9/16	1/2	1/16	7/8
BK100H	9.75	9.00	9.40	3	1 9/16	1/2	1/16	7/8
BK105H	10.25	9.50	9.90	3	1 9/16	1/2	1/16	7/8
BK110H	10.75	10.00	10.40	3	1 9/16	1/2	1/16	7/8
BK115H	11.25	10.50	10.90	3	1 9/16	1/2	1/16	7/8
BK120H	11.75	11.00	11.40	3	1 9/16	1/2	1/16	7/8
BK130H	12.75	12.00	12.40	3	1 9/16	1/2	1/16	7/8
BK140H	13.75	13.00	13.40	3	1 9/16	1/2	1/16	7/8
BK150H	14.75	14.00	14.40	3	1 9/16	1/2	1/16	7/8
BK160H	15.75	15.00	15.40	3	1 9/16	1/2	1/16	7/8
BK190H	18.75	18.00	18.40	3	1 9/16	1/2	1/16	7/8

BKH Sheaves are precision machined from gray cast iron, statically balanced, painted with baked enamel finish and individually packaged.

Millimeter Bores

Bore Range	Keyseat
10 mm	None
11 mm	None
14 mm	5 mm x 5 mm
15 mm	5 mm x 5 mm
16 mm	5 mm x 5 mm
18 mm	6 mm x 6 mm
19 mm	6 mm x 6 mm
20 mm	6 mm x 6 mm
22 mm	6 mm x 6 mm
24 mm	8 mm x 7 mm
25 mm	8 mm x 7 mm
28 mm	8 mm x 7 mm
30 mm	8 mm x 7 mm
32 mm	10 mm x 7 mm
35 mm	10 mm x 7 mm
38 mm	10 mm x 7 mm

H BUSHING SHEAVES 2BK

Two Groove Sheaves for "4L" "5L" "A" & "B" Belts

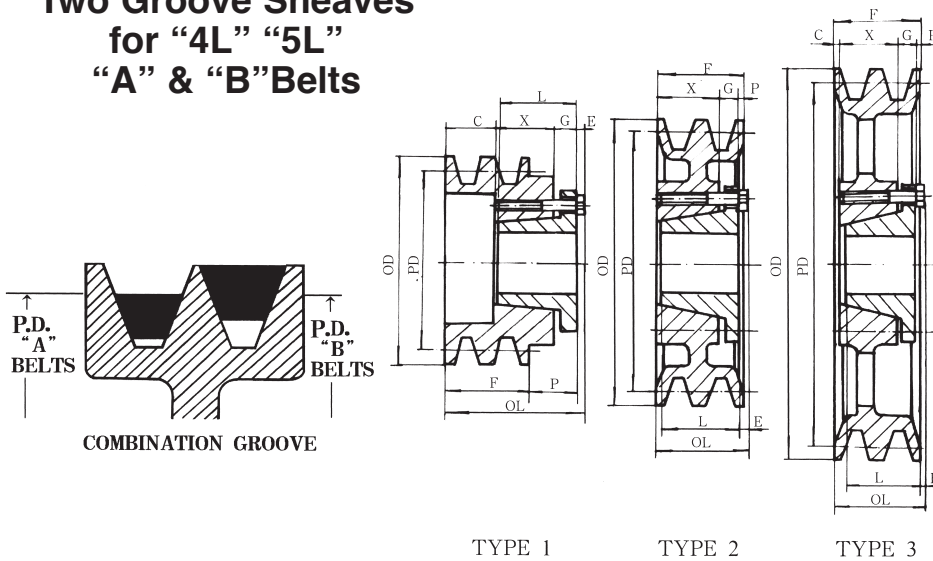

For All Sheaves:
 F = 1 3/4
 L = 1 1/4
 X = 7/8
 G = 7/16
 E = 3/16

Stock H Bushings

Stock Bores	Keyseat
3/8	None
7/16	None
1/2	1/8 x 1/16
9/16	1/8 x 1/16
5/8	3/16 x 3/32
11/16	3/16 x 3/32
3/4	3/16 x 3/32
13/16	3/16 x 3/32
7/8	3/16 x 3/32
15/16	1/4 x 1/8
1	1/4 x 1/8
1 1/16	1/4 x 1/8
1 1/8	1/4 x 1/8
1 3/16	1/4 x 1/8
1 1/4	1/4 x 1/8
1 5/16	5/16 x 1/16*
1 3/8	5/16 x 1/16*
1 7/16	3/8 x 1/16*
1 1/2	3/8 x 1/16*

* Indicates shallow keyseat—keystock is supplied with bushing.

Part No.	Diameters (in.)		Type	Dimensions (in.)			
	O.D.	Pitch		O.L.	P	C	
		"4L+A"					"5L+B"
2BK32H	3.35	2.60	3.00	1	2 13/16	7/8	1 5/16
2BK34H	3.55	2.80	3.20	1	2 13/16	7/8	1 5/16
2BK36H	3.75	3.00	3.40	1	2 3/8	7/16	7/8
2BK40H	3.95	3.20	3.60	1	2 3/8	7/16	7/8
2BK45H	4.25	3.50	3.90	1	2 3/8	7/16	7/8
2BK47H	4.45	3.70	4.10	2	1 3/4	7/16	—
2BK50H	4.75	4.00	4.40	2	1 3/4	7/16	—
2BK52H	4.95	4.20	4.60	2	1 3/4	7/16	—
2BK55H	5.25	4.50	4.90	2	1 3/4	7/16	—
2BK57H	5.45	4.70	5.10	2	1 3/4	7/16	—
2BK60H	5.75	5.00	5.40	2	1 3/4	7/16	—
2BK62H	5.95	5.20	5.60	2	1 3/4	7/16	—
2BK65H	6.25	5.50	5.90	3	1 3/4	7/16	1/4
2BK67H	6.45	5.70	6.10	3	1 3/4	7/16	1/4
2BK70H	6.75	6.00	6.40	3	1 3/4	7/16	1/4
2BK80H	7.75	7.00	7.40	3	1 3/4	7/16	1/4
2BK90H	8.75	8.00	8.40	3	1 3/4	7/16	1/4
2BK100H	9.75	9.00	9.40	3	1 3/4	7/16	1/4
2BK110H	10.75	10.00	10.40	3	1 3/4	7/16	1/4
2BK120H	11.75	11.00	11.40	3	1 3/4	7/16	1/4
2BK130H	12.75	12.00	12.40	3	1 3/4	7/16	1/4
2BK140H	13.75	13.00	13.40	3	1 3/4	7/16	1/4
2BK160H	15.75	15.00	15.40	3	1 3/4	7/16	1/4
2BK190H	18.75	18.00	18.40	3	1 3/4	7/16	1/4

2BKH Sheaves are precision machined from gray cast iron, statically balanced, painted with baked enamel finish and individually packaged.

Millimeter Bores

Bore Range	Keyseat
10 mm	None
11 mm	None
14 mm	5 mm x 5 mm
15 mm	5 mm x 5 mm
16 mm	5 mm x 5 mm
18 mm	6 mm x 6 mm
19 mm	6 mm x 6 mm
20 mm	6 mm x 6 mm
22 mm	6 mm x 6 mm
24 mm	8 mm x 7 mm
25 mm	8 mm x 7 mm
28 mm	8 mm x 7 mm
30 mm	8 mm x 7 mm
32 mm	10 mm x 7 mm
35 mm	10 mm x 7 mm
38 mm	10 mm x 7 mm

Heavy Duty One and Two Groove Sheaves

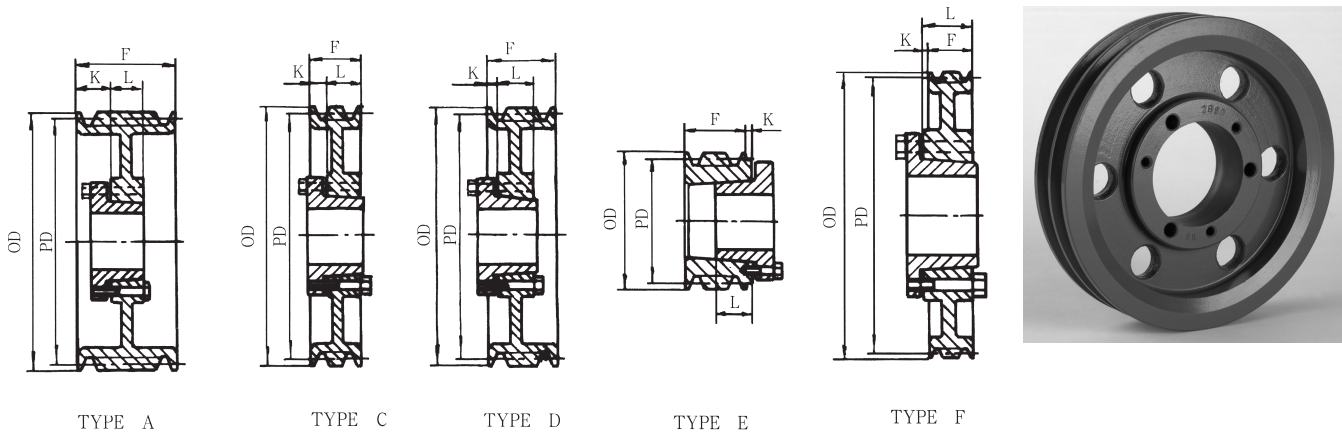

O.D.	P.D.		1 Groove F = 7/8 thru 1B 64 SDS/F = 1					2 Groove F = 1 3/4				
	A	B	Part No.	Bush	Type*	K	L	Part No.	Bush	Type*	K	L
3.75	3.00	3.40	1B34SH	SH	D-1	0"	1 5/16	2B34SH	SH	E-1	0	1 5/16
3.95	3.20	3.60	1B36SH	SH	D-1	0	1 5/16	2B36SH	SH	D-1	3/16	1 5/16
4.15	3.40	3.80	1B38SH	SH	D-1	0	1 5/16	2B38SH	SH	D-1	3/16	1 5/16
4.35	3.60	4.00	1B40SH	SH	C-1	1/16	1 5/16	2B40SH	SH	A-1	1 1/16	1 5/16
4.55	3.80	4.20	1B42SH	SH	C-1	1/16	1 5/16	2B42SH	SH	A-1	1 1/16	1 5/16
4.75	4.00	4.40	1B44SH	SH	C-1	1/16	1 5/16	2B44SH	SH	A-1	1 1/16	1 5/16
4.95	4.20	4.60	1B46SDS	SDS	C-1	1/8	1 5/16	2B46SDS	SDS	A-1	1 1/16	1 5/16
5.15	4.40	4.80	1B48SDS	SDS	C-1	1/8	1 5/16	2B48SDS	SDS	A-1	1 1/16	1 5/16
5.35	4.60	5.00	1B50SDS	SDS	C-1	1/8	1 5/16	2B50SDS	SDS	A-1	1 1/16	1 5/16
5.55	4.80	5.20	1B52SDS	SDS	C-1	1/8	1 5/16	2B52SDS	SDS	A-1	1 1/16	1 5/16
5.75	5.00	5.40	1B54SDS	SDS	C-1	1/8	1 5/16	2B54SDS	SDS	A-1	1 1/16	1 5/16
5.95	5.20	5.60	1B56SDS	SDS	C-1	1/8	1 5/16	2B56SDS	SDS	A-1	1 1/16	1 5/16
6.15	5.40	5.80	1B58SDS	SDS	C-1	1/8	1 5/16	2B58SDS	SDS	A-1	1 1/16	1 5/16
6.35	5.60	6.00	1B60SDS	SDS	C-2	1/8	1 5/16	2B60SDS	SDS	A-2	1 1/16	1 5/16
6.55	5.80	6.20	1B62SDS	SDS	C-2	1/8	1 5/16	2B62SDS	SDS	A-2	1 1/16	1 5/16
6.75	6.00	6.40	1B64SDS	SDS	C-2	1/8	1 5/16	2B64SDS	SDS	A-2	1 1/16	1 5/16
6.95	6.20	6.60	1B66SDS	SDS	C-2	1/4	1 5/16	2B66SDS	SDS	A-2	1 1/16	1 5/16
7.15	6.40	6.80	1B68SDS	SDS	C-2	1/4	1 5/16	2B68SDS	SDS	A-2	1 1/16	1 5/16
7.35	6.60	7.00	1B70SDS	SDS	C-2	1/4	1 5/16	2B70SK	SK	D-2	7/16	1 15/16
7.75	7.00	7.40	1B74SDS	SDS	C-2	1/4	1 5/16	2B74SK	SK	D-2	7/16	1 15/16
8.35	7.60	8.00	1B80SDS	SDS	C-2	1/4	1 5/16	2B80SK	SK	D-2	7/16	1 15/16
8.95	8.20	8.60	1B86SDS	SDS	C-3	1/4	1 5/16	2B86SK	SK	D-3	7/16	1 15/16
9.75	9.00	9.40	1B94SDS	SDS	C-3	1/4	1 5/16	2B94SK	SK	D-3	7/16	1 15/16
11.35	10.60	11.00	1B110SDS	SDS	C-3	1/4	1 5/16	2B110SK	SK	D-3	7/16	1 15/16
12.75	12.00	12.40	1B124SDS	SDS	C-3	1/4	1 5/16	2B124SK	SK	D-3	7/16	1 15/16
13.95	13.20	13.60	1B136SDS	SDS	C-3	1/4	1 5/16	2B136SK	SK	D-3	7/16	1 15/16
15.75	15.00	15.40	1B154SK	SK	F-3	1/4	1 15/16	2B154SK	SK	D-3	7/16	1 15/16
16.35	15.60	16.00	1B160SK	SK	F-3	1/4	1 15/16	2B160SK	SK	D-3	7/16	1 15/16
18.75	18.00	18.40	1B184SK	SK	F-3	1/4	1 15/16	2B184SK	SK	D-3	7/16	1 15/16
20.35	19.60	20.00	1B200SK	SK	F-3	1/4	1 15/16	2B200SF	SF	D-3	3/8	2 1/16
25.35	24.60	25.00	1B250SF	SF	F-3	1/4	1 1/4	2B250SF	SF	D-3	3/8	2 1/16
30.35	29.60	30.00	1B300SF	SF	F-3	1/4	1 1/4	2B300SF	SF	D-3	3/8	2 1/16
38.35	37.60	38.00						2B380SF	SF	D-3	3/8	2 1/16

*Suffix on Type indicates construction:
1 = Solid 2 = Web 3 = Arm/Spoke

Order bushings separately from pages 30-31.

Sheaves are precision machined from gray cast iron, statically balanced, painted with baked enamel finish and individually packaged.

Heavy Duty Three and Four Groove Sheaves

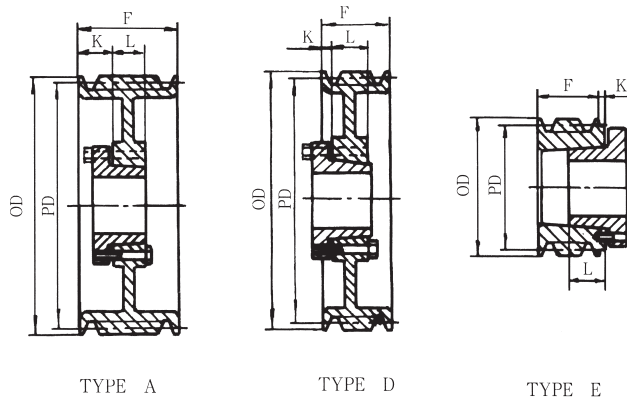

O.D.	P.D.		3 Groove F = 2 1/2					4 Groove F = 3 1/4				
	A	B	Part No.	Bush	Type*	K	L	Part No.	Bush	Type*	K	L
3.75	3.00	3.40	3B34SH	SH	E-1	0	1 5/16	4B34SD	SD	E-1	5/16	1 13/16
3.95	3.20	3.60	3B36SH	SH	D-1	3/16	1 5/16	4B36SD	SD	E-1	5/16	1 13/16
4.15	3.40	3.80	3B38SH	SH	D-1	3/16	1 5/16	4B38SD	SD	E-1	5/16	1 13/16
4.35	3.60	4.00	3B40SH	SH	A-1	1 1/16	1 5/16	4B40SD	SD	E-1	0	1 13/16
4.55	3.80	4.20	3B42SH	SH	A-1	1 1/16	1 5/16	4B42SD	SD	E-1	0	1 13/16
4.75	4.00	4.40	3B44SH	SH	A-1	1 1/16	1 5/16	4B44SD	SD	E-1	0	1 13/16
4.95	4.20	4.60	3B46SD	SD	A-1	1 1/16	1 13/16	4B46SD	SD	A-1	1 5/16	1 13/16
5.15	4.40	4.80	3B48SD	SD	A-1	1 1/16	1 13/16	4B48SD	SD	A-1	1 5/16	1 13/16
5.35	4.60	5.00	3B50SD	SD	A-1	1 1/16	1 13/16	4B50SD	SD	A-1	1 5/16	1 13/16
5.55	4.80	5.20	3B52SD	SD	A-1	1 1/16	1 13/16	4B52SD	SD	A-1	1 5/16	1 13/16
5.75	5.00	5.40	3B54SD	SD	A-1	1 1/16	1 13/16	4B54SD	SD	A-1	1 5/16	1 13/16
5.95	5.20	5.60	3B56SD	SD	A-1	1 1/16	1 13/16	4B56SD	SD	A-1	1 5/16	1 13/16
6.15	5.40	5.80	3B58SD	SD	A-1	1 1/16	1 13/16	4B58SD	SD	A-1	1 5/16	1 13/16
6.35	5.60	6.00	3B60SD	SD	A-1	1 1/16	1 13/16	4B60SD	SD	A-1	1 5/16	1 13/16
6.55	5.80	6.20	3B62SD	SD	A-2	1 1/16	1 13/16	4B62SD	SD	A-2	1 5/16	1 13/16
6.75	6.00	6.40	3B64SD	SD	A-2	1 1/16	1 13/16	4B64SD	SD	A-2	1 5/16	1 13/16
6.95	6.20	6.60	3B66SD	SD	A-2	1 1/16	1 15/16	4B66SD	SD	A-2	1 5/16	1 13/16
7.15	6.40	6.80	3B68SD	SD	A-2	1 1/16	1 15/16	4B68SD	SD	A-2	1 5/16	1 13/16
7.35	6.60	7.00	3B70SK	SK	A-2	1 1/16	1 15/16	4B70SK	SK	A-2	1	1 15/16
7.75	7.00	7.40	3B74SK	SK	A-2	1 1/16	1 15/16	4B74SK	SK	A-2	1	1 15/16
8.35	7.60	8.00	3B80SK	SK	A-2	1 1/16	1 15/16	4B80SK	SK	A-2	1	1 15/16
8.95	8.20	8.60	3B86SK	SK	A-3	1 1/16	1 15/16	4B86SK	SK	A-2	1	1 15/16
9.75	9.00	9.40	3B94SK	SK	A-3	1 1/16	1 15/16	4B94SK	SK	A-3	1	1 15/16
11.35	10.60	11.00	3B110SK	SK	A-3	1 1/16	1 15/16	4B110SK	SK	A-3	1	1 15/16
12.75	12.00	12.40	3B124SK	SK	A-3	1 1/16	1 15/16	4B124SK	SK	A-3	1	1 15/16
13.95	13.20	13.60	3B136SK	SK	A-3	1 1/16	1 15/16	4B136SK	SK	A-3	1	1 15/16
15.75	15.00	15.40	3B154SK	SK	A-3	1 1/16	1 15/16	4B154SF	SF	A-3	1	2 1/16
16.35	15.60	16.00	3B160SK	SK	A-3	1 1/16	1 15/16	4B160SF	SF	A-3	1	2 1/16
18.75	18.00	18.40	3B184SK	SK	A-3	1 1/16	1 15/16	4B184SF	SF	A-3	1	2 1/16
20.35	19.60	20.00	3B200SF	SF	D-3	5/8	2 1/16	4B200SF	SF	A-3	1	2 1/16
25.35	24.60	25.00	3B250SF	SF	D-3	5/8	2 1/16	4B250E	E	A-3	1	2 3/4
30.35	29.60	30.00	3B300SF	SF	D-3	5/8	2 1/16	4B300E	E	A-3	1	2 3/4
38.35	37.60	38.00	3B380E	E	D-3	5/8	2 3/4	4B380E	E	A-3	1	2 3/4

*Suffix on Type indicates construction:
 1 = Solid 2 = Web 3 = Arm/Spoke

Order bushings separately from pages 30-31.

Sheaves are precision machined from gray cast iron, statically balanced, painted with baked enamel finish and individually packaged.

Heavy Duty Five and Six Groove Sheaves

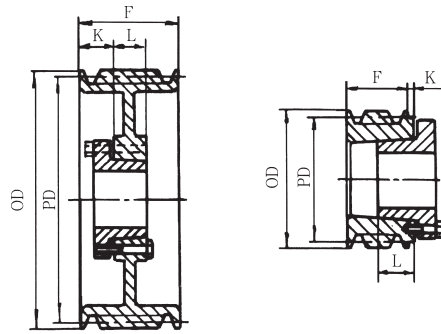

TYPE A

TYPE E

O.D.	P.D.		5 Groove F = 4					6 Groove F = 4¾				
	A	B	Part No.	Bush	Type*	K	L	Part No.	Bush	Type*	K	L
3.75	3.00	3.40	5B34SD	SD	E-1	5/16	1 13/16	6B34SD	SD	E-1	5/16	1 13/16
3.95	3.20	3.60	5B36SD	SD	E-1	5/16	1 13/16	6B36SD	SD	E-1	5/16	1 13/16
4.15	3.40	3.80	5B38SD	SD	E-1	5/16	1 13/16	6B38SD	SD	E-1	5/16	1 13/16
4.35	3.60	4.00	5B40SD	SD	E-1	0	1 13/16	6B40SD	SD	E-1	0	1 13/16
4.55	3.80	4.20	5B42SD	SD	E-1	0	1 13/16	6B42SD	SD	E-1	0	1 13/16
4.75	4.00	4.40	5B44SD	SD	E-1	0	1 13/16	6B44SD	SD	E-1	0	1 13/16
4.95	4.20	4.60	5B46SD	SD	A-1	1 5/16	1 13/16	6B46SD	SD	A-1	1 3/16	1 13/16
5.15	4.40	4.80	5B48SD	SD	A-1	1 5/16	1 13/16	6B48SD	SD	A-1	1 3/16	1 13/16
5.35	4.60	5.00	5B50SD	SD	A-1	1 5/16	1 13/16	6B50SD	SD	A-1	1 3/16	1 13/16
5.55	4.80	5.20	5B52SD	SD	A-1	1 5/16	1 13/16	6B52SD	SD	A-1	1 3/16	1 13/16
5.75	5.00	5.40	5B54SK	SK	A-1	1 5/16	1 15/16	6B54SK	SK	A-1	1 5/16	1 15/16
5.95	5.20	5.60	5B56SK	SK	A-1	1 5/16	1 15/16	6B56SK	SK	A-1	1 5/16	1 15/16
6.15	5.40	5.80	5B58SK	SK	A-1	1 5/16	1 15/16	6B58SK	SK	A-1	1 5/16	1 15/16
6.35	5.60	6.00	5B60SK	SK	A-1	1 5/16	1 15/16	6B60SK	SK	A-1	1 5/16	1 15/16
6.55	5.80	6.20	5B62SK	SK	A-1	1 5/16	1 15/16	6B62SK	SK	A-1	1 5/16	1 15/16
6.75	6.00	6.40	5B64SK	SK	A-1	1 5/16	1 15/16	6B64SK	SK	A-1	1 5/16	1 15/16
6.95	6.20	6.60	5B66SK	SK	A-1	1 5/16	1 15/16	6B66SK	SK	A-1	1 5/16	1 15/16
7.15	6.40	6.80	5B68SK	SK	A-1	1 5/16	1 15/16	6B68SK	SK	A-1	1 5/16	1 15/16
7.35	6.60	7.00	5B70SF	SF	A-1	1 5/16	2 1/16	6B70SF	SF	A-1	1 11/16	2 1/16
7.75	7.00	7.40	5B74SF	SF	A-1	1 5/16	2 1/16	6B74SF	SF	A-2	1 11/16	2 1/16
8.35	7.60	8.00	5B80SF	SF	A-2	1 5/16	2 1/16	6B80SF	SF	A-2	1 11/16	2 1/16
8.95	8.20	8.60	5B86SF	SF	A-2	1 5/16	2 1/16	6B86SF	SF	A-2	1 11/16	2 1/16
9.75	9.00	9.40	5B94SF	SF	A-2	1 5/16	2 1/16	6B94SF	SF	A-2	1 11/16	2 1/16
11.35	10.60	11.00	5B110SF	SF	A-3	1 5/16	2 1/16	6B110SF	SF	A-3	1 11/16	2 1/16
12.75	12.00	12.40	5B124SF	SF	A-3	1 5/16	2 1/16	6B124SF	SF	A-3	1 11/16	2 1/16
13.95	13.20	13.60	5B136SF	SF	A-3	1 5/16	2 1/16	6B136SF	SF	A-3	1 11/16	2 1/16
15.75	15.00	15.40	5B154SF	SF	A-3	1 5/16	2 1/16	6B154SF	SF	A-3	1 11/16	2 1/16
16.35	15.60	16.00	5B160SF	SF	A-3	1 5/16	2 1/16	6B160SF	SF	A-3	1 11/16	2 1/16
18.75	18.00	18.40	5B184SF	SF	A-3	1 5/16	2 1/16	6B184SF	SF	A-3	1 11/16	2 1/16
20.35	19.60	20.00	5B200E	E	A-3	1 1/4	2 3/4	6B200E	E	A-3	1 3/8	2 3/4
25.35	24.60	25.00	5B250E	E	A-3	1 1/4	2 3/4	6B250E	E	A-3	1 3/8	2 3/4
30.35	29.60	30.00	5B300E	E	A-3	1 1/4	2 3/4	6B300E	E	A-3	1 3/8	2 3/4
38.35	37.60	38.00	5B380E	E	A-3	1 1/4	2 3/4	6B380E	E	A-3	1 3/8	2 3/4

*Suffix on Type indicates construction:
 1 = Solid 2 = Web 3 = Arm/Spoke

Order bushings separately from pages 30-31.

Sheaves are precision machined from gray cast iron, statically balanced, painted with baked enamel finish and individually packaged.

Heavy Duty Eight and Ten Groove Sheaves

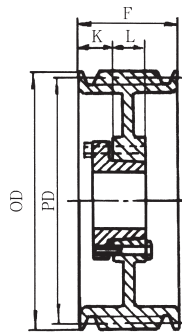

TYPE A

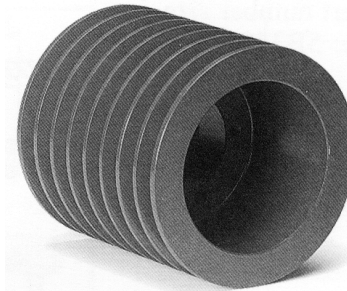

O.D.	P.D.		8 Groove F = 6¼					10 Groove F = 7¾				
	A	B	Part No.	Bush	Type*	K	L	Part No.	Bush	Type*	K	L
5.75	5.00	5.40	8B54SK	SK	A-1	1 13/16	1 15/16	10B54SK	SK	A-1	2 9/16	1 15/16
5.95	5.20	5.60	8B56SK	SK	A-1	1 13/16	1 15/16	10B56SK	SK	A-1	2 9/16	1 15/16
6.15	5.40	5.80	8B58SK	SK	A-1	1 13/16	1 15/16	10B58SK	SK	A-1	2 9/16	1 15/16
6.35	5.60	6.00	8B60SK	SK	A-1	1 13/16	1 15/16	10B60SK	SK	A-1	2 9/16	1 15/16
6.55	5.80	6.20	8B62SF	SF	A-1	1 13/16	2 1/16	10B62SF	SF	A-1	2 9/16	2 1/16
6.75	6.00	6.40	8B64SF	SF	A-1	1 13/16	2 1/16	10B64SF	SF	A-1	2 9/16	2 1/16
6.95	6.20	6.60	8B66SF	SF	A-1	1 13/16	2 1/16	10B66SF	SF	A-1	2 9/16	2 1/16
7.15	6.40	6.80	8B68SF	SF	A-1	1 13/16	2 1/16	10B68SF	SF	A-1	2 9/16	2 1/16
7.35	6.60	7.00	8B70SF	SF	A-1	1 13/16	2 1/16	10B70SF	SF	A-1	2 9/16	2 1/16
7.75	7.00	7.40	8B74SF	SF	A-1	1 13/16	2 1/16	10B74SF	SF	A-1	2 9/16	2 1/16
8.95	8.20	8.60	8B86E	E	A-1	2 3/8	2 3/4	10B86E	E	A-1	3 1/8	2 3/4
9.75	9.00	9.40	8B94E	E	A-1	2 3/8	2 3/4	10B94E	E	A-2	3 1/8	2 3/4
11.35	10.60	11.00	8B110E	E	A-2	2 3/8	2 3/4	10B110E	E	A-2	3 1/8	2 3/4
12.75	12.00	12.40	8B124E	E	A-3	2 3/8	2 3/4	10B124E	E	A-3	3 1/8	2 3/4
13.95	13.20	13.60	8B136E	E	A-3	2 3/8	2 3/4	10B136F	F	A-3	2 1/16	3 3/4
15.75	15.00	15.40	8B154E	E	A-3	2 3/8	2 3/4	10B154F	F	A-3	2 1/16	3 3/4
16.35	15.60	16.00	8B160E	E	A-3	2 3/8	2 3/4	10B160F	F	A-3	2 1/16	3 3/4
18.75	18.00	18.40	8B184F	F	A-3	1 5/16	3 3/4	10B184F	F	A-3	2 1/16	3 3/4
20.35	19.60	20.00	8B200F	F	A-3	1 5/16	3 3/4	10B200F	F	A-3	2 1/16	3 3/4
25.35	24.60	25.00	8B250F	F	A-3	1 5/16	3 3/4	10B250F	F	A-3	2 1/16	3 3/4
30.35	29.60	30.00	8B300F	F	A-3	1 5/16	3 3/4	10B300F	F	A-3	2 1/16	3 3/4
38.35	37.60	38.00	8B380F	F	A-3	1 5/16	3 3/4	10B380J	J	A-3	1 9/16	4 5/8

*Suffix on Type indicates construction:
 1 = Solid 2 = Web 3 = Arm/Spoke

Order bushings separately from pages 30-31.

Sheaves are precision machined from gray cast iron, statically balanced, painted with baked enamel finish and individually packaged.

Heavy Duty One and Two Groove C-QD® Sheaves

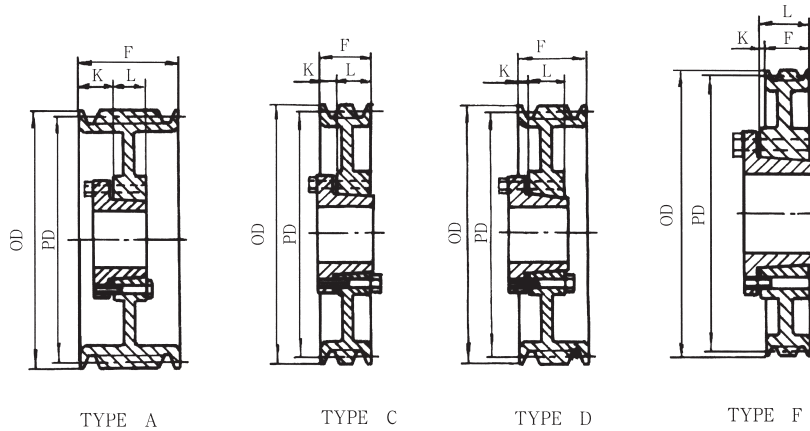

Diameters		1 Groove F = 1 3/8					2 Groove F = 2 3/8				
O.D.	P.D.	Part No.	Bush	Type*	K	L	Part No.	Bush	Type*	K	L
6.40	6.00	1C60SK	SK	C-1	1/8	1 15/16	2C60SF	SF	A-1	7/8	1 15/16
7.40	7.00	1C70SF	SF	C-1	1/8	2 1/16	2C70SF	SF	A-1	13/16	2 1/16
7.90	7.50	1C75SF	SF	C-1	1/8	2 1/16	2C75SF	SF	A-1	13/16	2 1/16
8.40	8.00	1C80SF	SF	C-1	1/8	2 1/16	2C80SF	SF	A-1	13/16	2 1/16
8.90	8.50	1C85SF	SF	C-2	1/8	2 1/16	2C85SF	SF	A-2	13/16	2 1/16
9.40	9.00	1C90SF	SF	C-2	1/8	2 1/16	2C90SF	SF	A-2	13/16	2 1/16
9.90	9.50	1C95SF	SF	C-2	1/8	2 1/16	2C95SF	SF	A-2	13/16	2 1/16
10.40	10.00	1C100SF	SF	C-2	1/8	2 1/16	2C100SF	SF	A-2	13/16	2 1/16
10.90	10.50	1C105SF	SF	C-3	1/8	2 1/16	2C105SF	SF	A-3	13/16	2 1/16
11.40	11.00	1C110SF	SF	C-3	1/8	2 1/16	2C110SF	SF	A-3	13/16	2 1/16
12.40	12.00	1C120SF	SF	C-3	1/8	2 1/16	2C120SF	SF	D-3	9/16	2 1/16
13.40	13.00	1C130SF	SF	C-3	1/8	2 1/16	2C130SF	SF	D-3	9/16	2 1/16
14.40	14.00	1C140SF	SF	C-3	1/8	2 1/16	2C140SF	SF	D-3	9/16	2 1/16
15.40	15.00	1C150SF	SF	C-3	1/8	2 1/16	2C150SF	SF	D-3	9/16	2 1/16
16.40	16.00	1C160SF	SF	C-3	1/8	2 1/16	2C160SF	SF	D-3	9/16	2 1/16
18.40	18.00	1C180SF	SF	C-3	1/8	2 1/16	2C180SF	SF	D-3	9/16	2 1/16
20.40	20.00	1C200SF	SF	C-3	1/8	2 1/16	2C200SF	SF	D-3	9/16	2 1/16
24.40	24.00	1C240SF	SF	C-3	1/8	2 1/16	2C240SF	SF	D-3	9/16	2 1/16
27.40	27.00						2C270F	F	F-3	1/8	3 3/4
30.40	30.00						2C300F	F	F-3	1/8	3 3/4

*Suffix on Type indicates construction:
 1 = Solid 2 = Web 3 = Arm/Spoke

Order bushings separately from pages 30-31.

Sheaves are precision machined from gray cast iron, statically balanced, painted with baked enamel finish and individually packaged.

Heavy Duty Three and Four Groove C-QD[®] Sheaves

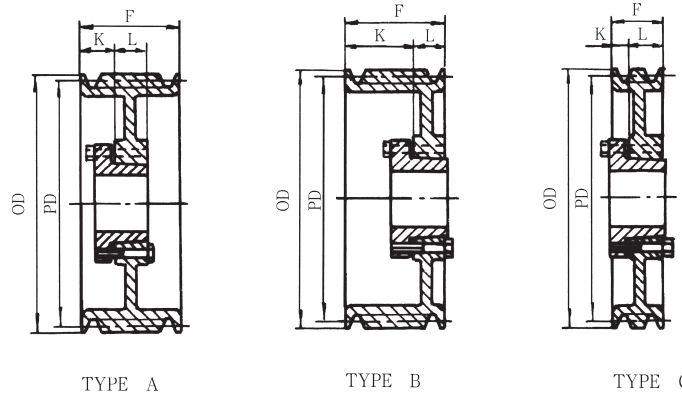

Diameters		3 Groove F = 3 ³ / ₈					4 Groove F = 4 ³ / ₈				
O.D.	P.D.	Part No.	Bush	Type*	K	L	Part No.	Bush	Type*	K	L
5.40	5.00	3C50SD	SD	A-1	1 ¹ / ₄	1 ¹³ / ₁₆	4C50SD	SD	A-1	1 ¹ / ₄	1 ¹³ / ₁₆
5.80	5.40	3C54SD	SD	A-1	1 ⁵ / ₁₆	1 ¹³ / ₁₆	4C54SD	SD	A-1	1 ⁵ / ₁₆	1 ¹³ / ₁₆
5.90	5.50	3C55SD	SD	A-1	1 ⁵ / ₁₆	1 ¹³ / ₁₆	4C55SD	SD	A-1	1 ⁵ / ₁₆	1 ¹³ / ₁₆
6.00	5.60	3C56SD	SD	A-1	1 ⁵ / ₁₆	1 ¹³ / ₁₆	4C56SD	SD	A-1	1 ⁵ / ₁₆	1 ¹³ / ₁₆
6.40	6.00	3C60SF	SF	A-1	7 ⁷ / ₈	1 ¹⁵ / ₁₆	4C60SF	SF	A-1	7 ⁷ / ₈	1 ¹⁵ / ₁₆
7.40	7.00	3C70SF	SF	A-1	1 ⁵ / ₁₆	2 ¹ / ₁₆	4C70SF	SF	A-1	1 ⁹ / ₁₆	2 ¹ / ₁₆
7.90	7.50	3C75SF	SF	A-1	1 ⁵ / ₁₆	2 ¹ / ₁₆	4C75SF	SF	A-1	1 ⁹ / ₁₆	2 ¹ / ₁₆
8.40	8.00	3C80E	E	B-1	1 ³ / ₄	2 ³ / ₄	4C80E	E	A-1	2	2 ³ / ₄
8.90	8.50	3C85E	E	B-1	1 ³ / ₄	2 ³ / ₄	4C85E	E	A-1	2	2 ³ / ₄
9.40	9.00	3C90E	E	B-1	1 ³ / ₄	2 ³ / ₄	4C90E	E	A-1	2	2 ³ / ₄
9.90	9.50	3C95E	E	B-1	1 ³ / ₄	2 ³ / ₄	4C95E	E	A-1	2	2 ³ / ₄
10.40	10.00	3C100E	E	B-2	1 ³ / ₄	2 ³ / ₄	4C100E	E	A-2	2	2 ³ / ₄
10.90	10.50	3C105E	E	B-2	1 ³ / ₄	2 ³ / ₄	4C105E	E	A-2	2	2 ³ / ₄
11.40	11.00	3C110E	E	B-3	1 ³ / ₄	2 ³ / ₄	4C110E	E	A-3	2	2 ³ / ₄
12.40	12.00	3C120E	E	B-3	1 ³ / ₄	2 ³ / ₄	4C120E	E	A-3	2	2 ³ / ₄
13.40	13.00	3C130E	E	B-3	1 ³ / ₄	2 ³ / ₄	4C130E	E	A-3	2	2 ³ / ₄
14.40	14.00	3C140E	E	B-3	1 ³ / ₄	2 ³ / ₄	4C140E	E	A-3	2	2 ³ / ₄
15.40	15.00	3C150E	E	B-3	1 ³ / ₄	2 ³ / ₄	4C150E	E	A-3	2	2 ³ / ₄
16.40	16.00	3C160E	E	B-3	1 ³ / ₄	2 ³ / ₄	4C160E	E	A-3	2	2 ³ / ₄
18.40	18.00	3C180E	E	B-3	1 ³ / ₄	2 ³ / ₄	4C180E	E	A-3	2	2 ³ / ₄
20.40	20.00	3C200E	E	A-3	1	2 ³ / ₄	4C200E	E	A-3	1 ¹ / ₂	2 ³ / ₄
24.40	24.00	3C240E	E	A-3	1	2 ³ / ₄	4C240F	F	A-3	1 ⁵ / ₁₆	3 ³ / ₄
27.40	27.00	3C270F	F	C-3	7 ⁷ / ₈	3 ³ / ₄	4C270F	F	A-3	1 ⁵ / ₁₆	3 ³ / ₄
30.40	30.00	3C300F	F	C-3	7 ⁷ / ₈	3 ³ / ₄	4C300F	F	A-3	1 ⁵ / ₁₆	3 ³ / ₄
36.40	36.00	3C360F	F	C-3	7 ⁷ / ₈	3 ³ / ₄	4C360F	F	A-3	1 ⁵ / ₁₆	3 ³ / ₄
44.40	44.00	3C440F	F	C-3	1 ³ / ₁₆	3 ³ / ₄	4C440J	J	A-3	1 ⁹ / ₁₆	4 ⁵ / ₈
50.40	50.00	3C500F	F	C-3	1 ³ / ₁₆	3 ³ / ₄	4C500J	J	A-3	1 ⁹ / ₁₆	4 ⁵ / ₈

*Suffix on Type indicates construction:
 1 = Solid 2 = Web 3 = Arm/Spoke

Order bushings separately from pages 30-31.

Sheaves are precision machined from gray cast iron, statically balanced, painted with baked enamel finish and individually packaged.

Heavy Duty Five and Six Groove C-QD® Sheaves

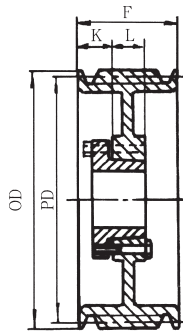

TYPE A



Diameters		5 Groove F = 5 3/8					6 Groove F = 6 3/8				
O.D.	P.D.	Part No.	Bush	Type*	K	L	Part No.	Bush	Type*	K	L
6.40	6.00	5C60SF	SF	A-1	7/8	1 15/16	6C60SF	SF	A-1	7/8	1 15/16
7.40	7.00	5C70SF	SF	A-1	1 15/16	2 1/16	6C70SF	SF	A-1	1 15/16	2 1/16
7.90	7.50	5C75SF	SF	A-1	1 15/16	2 1/16	6C75SF	SF	A-1	1 15/16	2 1/16
8.40	8.00	5C80E	E	A-1	2 3/8	2 3/4	6C80E	E	A-1	2 3/8	2 3/4
8.90	8.50	5C85E	E	A-1	2 3/8	2 3/4	6C85E	E	A-1	2 3/8	2 3/4
9.40	9.00	5C90E	E	A-1	2 3/8	2 3/4	6C90F	F	A-1	1 7/16	3 3/4
9.90	9.50	5C95E	E	A-1	2 3/8	2 3/4	6C95F	F	A-1	1 7/16	3 3/4
10.40	10.00	5C100E	E	A-2	2 3/8	2 3/4	6C100F	F	A-1	1 7/16	3 3/4
10.90	10.50	5C105E	E	A-2	2 3/8	2 3/4	6C105F	F	A-1	1 7/16	3 3/4
11.40	11.00	5C110E	E	A-3	2 3/8	2 3/4	6C110F	F	A-2	1 7/16	3 3/4
12.40	12.00	5C120E	E	A-3	2 3/8	2 3/4	6C120F	F	A-2	1 7/16	3 3/4
13.40	13.00	5C130E	E	A-3	2 3/8	2 3/4	6C130F	F	A-3	1 7/16	3 3/4
14.40	14.00	5C140E	E	A-3	2 3/8	2 3/4	6C140F	F	A-3	1 7/16	3 3/4
15.40	15.00	5C150E	E	A-3	2 3/8	2 3/4	6C150F	F	A-3	1 7/16	3 3/4
16.40	16.00	5C160E	E	A-3	2 3/8	2 3/4	6C160F	F	A-3	1 7/16	3 3/4
18.40	18.00	5C180E	E	A-3	2 3/8	2 3/4	6C180F	F	A-3	1 7/16	3 3/4
20.40	20.00	5C200F	F	A-3	1 5/16	3 3/4	6C200F	F	A-3	1 15/16	3 3/4
24.40	24.00	5C240F	F	A-3	1 5/16	3 3/4	6C240F	F	A-3	1 15/16	3 3/4
27.40	27.00	5C270F	F	A-3	1 5/16	3 3/4	6C270J	J	A-3	1 9/16	4 5/8
30.40	30.00	5C300F	F	A-3	1 5/16	3 3/4	6C300J	J	A-3	1 9/16	4 5/8
36.40	36.00	5C360J	J	A-3	1 9/16	4 5/8	6C360J	J	A-3	1 9/16	4 5/8
44.40	44.00	5C440J	J	A-3	1 9/16	4 5/8	6C440J	J	A-3	1 9/16	4 5/8
50.40	50.00	5C500J	J	A-3	1 9/16	4 5/8	6C500M	M	A-3	1 15/16	6 3/4

*Suffix on Type indicates construction:
 1 = Solid 2 = Web 3 = Arm/Spoke

Order bushings separately from pages 30-31.

Sheaves are precision machined from gray cast iron, statically balanced, painted with baked enamel finish and individually packaged.

Heavy Duty Eight and Ten Groove C-QD® Sheaves

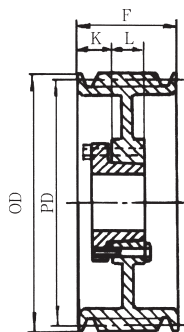

TYPE A



Diameters		8 Groove F = 8 ³ / ₈					10 Groove F = 10 ³ / ₈				
O.D.	P.D.	Part No.	Bush	Type*	K	L	Part No.	Bush	Type*	K	L
7.40	7.00	8C70SF	SF	A-1	3 ¹ / ₈	2 ¹ / ₁₆					
8.40	8.00	8C80E	E	A-1	3 ¹ / ₄	2 ³ / ₄	10C80E	E	A-1	3 ¹ / ₄	2 ³ / ₄
8.90	8.50	8C85E	E	A-1	3 ¹ / ₄	2 ³ / ₄	10C85E	E	A-1	3 ¹ / ₄	2 ³ / ₄
9.40	9.00	8C90F	F	A-1	3 ⁵ / ₁₆	3 ³ / ₄	10C90J	J	A-1	3 ⁹ / ₁₆	4 ⁵ / ₈
9.90	9.50	8C95F	F	A-1	3 ⁵ / ₁₆	3 ³ / ₄	10C95J	J	A-1	3 ⁹ / ₁₆	4 ⁵ / ₈
10.40	10.00	8C100F	F	A-1	3 ⁵ / ₁₆	3 ³ / ₄	10C100J	J	A-1	3 ⁹ / ₁₆	4 ⁵ / ₈
10.90	10.50	8C105F	F	A-1	3 ⁵ / ₁₆	3 ³ / ₄	10C105J	J	A-1	3 ⁹ / ₁₆	4 ⁵ / ₈
11.40	11.00	8C110F	F	A-1	3 ⁵ / ₁₆	3 ³ / ₄	10C110J	J	A-1	3 ⁹ / ₁₆	4 ⁵ / ₈
12.40	12.00	8C120F	F	A-2	3 ⁵ / ₁₆	3 ³ / ₄	10C120J	J	A-1	3 ⁹ / ₁₆	4 ⁵ / ₈
13.40	13.00	8C130F	F	A-2	3 ⁵ / ₁₆	3 ³ / ₄	10C130J	J	A-2	3 ⁹ / ₁₆	4 ⁵ / ₈
14.40	14.00	8C140F	F	A-2	3 ⁵ / ₁₆	3 ³ / ₄	10C140J	J	A-2	3 ⁹ / ₁₆	4 ⁵ / ₈
15.40	15.00	8C150F	F	A-2	3 ⁵ / ₁₆	3 ³ / ₄					
16.40	16.00	8C160F	F	A-3	3 ⁵ / ₁₆	3 ³ / ₄	10C160J	J	A-3	3 ⁹ / ₁₆	4 ⁵ / ₈
18.40	18.00	8C180F	F	A-3	3 ⁵ / ₁₆	3 ³ / ₄	10C180J	J	A-3	3 ⁹ / ₁₆	4 ⁵ / ₈
20.40	20.00	8C200J	J	A-3	1 ⁹ / ₁₆	4 ⁵ / ₈	10C200J	J	A-3	3 ⁹ / ₁₆	4 ⁵ / ₈
24.40	24.00	8C240J	J	A-3	1 ⁹ / ₁₆	4 ⁵ / ₈	10C240M	M	A-3	3 ⁹ / ₁₆	6 ³ / ₄
27.40	27.00	8C270J	J	A-3	1 ⁹ / ₁₆	4 ⁵ / ₈					
30.40	30.00	8C300J	J	A-3	1 ⁹ / ₁₆	4 ⁵ / ₈	10C300M	M	A-3	1 ¹⁵ / ₁₆	6 ³ / ₄
36.40	36.00	8C360M	M	A-3	1 ¹⁵ / ₁₆	6 ³ / ₄	10C360M	M	A-3	1 ¹⁵ / ₁₆	6 ³ / ₄
44.40	44.00	8C440M	M	A-3	1 ¹⁵ / ₁₆	6 ³ / ₄	10C440M	M	A-3	1 ¹⁵ / ₁₆	6 ³ / ₄
50.40	50.00	8C500M	M	A-3	1 ¹⁵ / ₁₆	6 ³ / ₄	10C500M	M	A-3	1 ¹⁵ / ₁₆	6 ³ / ₄

*Suffix on Type indicates construction:
 1 = Solid 2 = Web 3 = Arm/Spoke

Order bushings separately from pages 30-31.

Sheaves are precision machined from gray cast iron, statically balanced, painted with baked enamel finish and individually packaged.

Heavy Duty One and Two Groove 3V QD® Sheaves

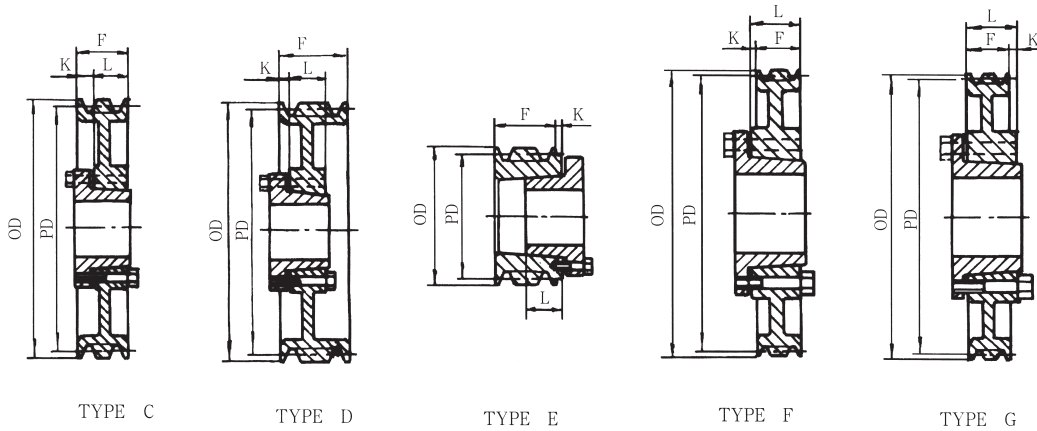

Diameters		1 Groove F = 11/16					2 Groove F = 1 3/32				
O.D.	P.D.	Part No.	Bush	Type*	K	L	Part No.	Bush	Type*	K	L
2.20	2.15	1-3V220JA	JA	E-1	7/16	1	2-3V220JA	JA	E-1	7/16	1
2.35	2.30	1-3V235JA	JA	E-1	7/16	1	2-3V235JA	JA	E-1	7/16	1
2.50	2.45	1-3V250JA	JA	E-1	7/16	1	2-3V250JA	JA	E-1	7/16	1
2.65	2.60	1-3V265JA	JA	C-1	1/8	1	2-3V265JA	JA	D-1	1/8	1
2.80	2.75	1-3V280JA	JA	C-1	1/8	1	2-3V280JA	JA	D-1	1/8	1
3.00	2.95	1-3V300JA	JA	C-1	1/8	1	2-3V300JA	JA	D-1	1/8	1
3.15	3.10	1-3V315JA	JA	C-1	1/8	1	2-3V315JA	JA	D-1	1/8	1
3.35	3.30	1-3V335JA	JA	C-1	1/8	1	2-3V335SH	SH	D-1	9/64	1 5/16
3.65	3.60	1-3V365SH	SH	G-1	1/8	1 5/16	2-3V365SH	SH	D-1	9/64	1 5/16
4.12	4.07	1-3V412SH	SH	G-1	1/8	1 5/16	2-3V412SH	SH	D-1	9/32	1 5/16
4.50	4.45	1-3V450SH	SH	G-1	1/8	1 5/16	2-3V450SH	SH	D-1	9/32	1 5/16
4.75	4.70	1-3V475SH	SH	G-1	1/8	1 5/16	2-3V475SH	SH	D-1	9/32	1 5/16
5.00	4.90	1-3V500SH	SH	G-1	1/8	1 5/16	2-3V500SH	SH	D-1	9/32	1 5/16
5.30	5.25	1-3V530SH	SH	G-2	1/8	1 5/16	2-3V530SH	SH	D-1	9/32	1 5/16
5.60	5.55	1-3V560SH	SH	G-2	1/8	1 5/16	2-3V560SH	SH	D-2	9/32	1 5/16
6.00	5.95	1-3V600SH	SH	G-2	1/8	1 5/16	2-3V600SH	SH	D-2	9/32	1 5/16
6.50	6.45	1-3V650SH	SH	G-2	1/8	1 5/16	2-3V650SDS	SDS	D-2	5/16	1 5/16
6.90	6.85	1-3V690SH	SH	G-3	1/8	1 5/16	2-3V690SDS	SDS	D-2	5/16	1 5/16
8.00	7.95	1-3V800SDS	SDS	G-3	0	1 5/16	2-3V800SDS	SDS	D-3	5/16	1 5/16
10.60	10.55	1-3V1060SDS	SDS	G-3	0	1 5/16	2-3V1060SK	SK	F-3	5/32	1 15/16
14.00	13.95	1-3V1400SK	SK	G-3	7/16	1 15/16	2-3V1400SK	SK	F-3	5/32	1 15/16
19.00	18.95	1-3V1900SK	SK	G-3	7/16	1 15/16	2-3V1900SK	SK	F-3	5/32	1 15/16
25.00	24.95						2-3V2500SF	SF	E-3	1/4	2 1/16

*Suffix on Type indicates construction:
 1 = Solid 2 = Web 3 = Arm/Spoke

Order bushings separately from pages 30-31.

Sheaves are precision machined from gray cast iron, statically balanced, painted with baked enamel finish and individually packaged.

Heavy Duty Three and Four Groove 3V QD[®] Sheaves

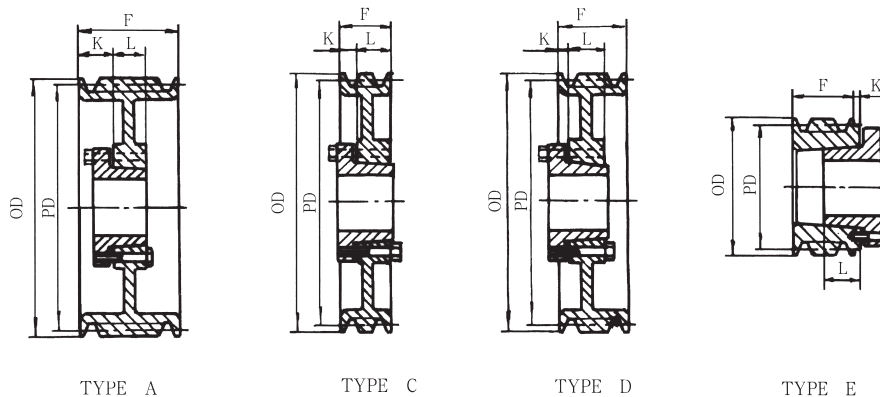

Diameters		3 Groove F = 1 1/2					4 Groove F = 1 29/32				
O.D.	P.D.	Part No.	Bush	Type*	K	L	Part No.	Bush	Type*	K	L
2.50	2.45	3-3V250JA	JA	E-1	7/16	1					
2.65	2.60	3-3V265JA	JA	D-1	1/8	1	4-3V265JA	JA	D-1	1/8	1
2.80	2.75	3-3V280JA	JA	D-1	1/8	1	4-3V280JA	JA	D-1	1/8	1
3.00	2.95	3-3V300SH	SH	E-1	5/16	1 5/16	4-3V300SH	SH	E-1	0	1 5/16
3.15	3.10	3-3V315SH	SH	E-1	5/16	1 5/16	4-3V315SH	SH	E-1	0	1 5/16
3.35	3.30	3-3V335SH	SH	D-1	1/8	1 5/16	4-3V335SH	SH	D-1	1/8	1 5/16
3.65	3.60	3-3V365SH	SH	D-1	1/8	1 5/16	4-3V365SH	SH	D-1	1/8	1 5/16
4.12	4.07	3-3V412SH	SH	A-1	11/16	1 5/16	4-3V412SH	SH	A-1	13/16	1 5/16
4.50	4.45	3-3V450SDS	SDS	A-1	11/16	1 5/16	4-3V450SDS	SDS	A-1	13/16	1 5/16
4.75	4.70	3-3V475SDS	SDS	A-1	11/16	1 5/16	4-3V475SDS	SDS	A-1	13/16	1 5/16
5.00	4.95	3-3V500SDS	SDS	A-1	11/16	1 5/16	4-3V500SDS	SDS	A-1	13/16	1 5/16
5.30	5.25	3-3V530SDS	SDS	A-1	11/16	1 5/16	4-3V530SDS	SDS	A-1	13/16	1 5/16
5.60	5.55	3-3V560SDS	SDS	A-1	11/16	1 5/16	4-3V560SDS	SDS	A-1	13/16	1 5/16
6.00	5.95	3-3V600SDS	SDS	A-2	11/16	1 5/16	4-3V600SK	SK	D-1	5/8	1 15/16
6.50	6.45	3-3V650SDS	SDS	A-2	11/16	1 5/16	4-3V650SK	SK	D-2	5/8	1 15/16
6.90	6.85	3-3V690SDS	SDS	A-2	11/16	1 5/16	4-3V690SK	SK	D-2	5/8	1 15/16
8.00	7.95	3-3V800SK	SK	C-3	1/4	1 15/16	4-3V800SK	SK	D-3	5/8	1 15/16
10.60	10.55	3-3V1060SK	SK	C-3	1/4	1 15/16	4-3V1060SK	SK	D-3	5/8	1 15/16
14.00	13.95	3-3V1400SK	SK	C-3	1/4	1 15/16	4-3V1400SK	SK	D-3	5/8	1 15/16
19.00	18.95	3-3V1900SF	SF	C-3	1/4	2 1/16	4-3V1900SF	SF	C-3	2 1/32	2 1/16
25.00	24.95	3-3V2500SF	SF	C-3	1/4	2 1/16	4-3V2500SF	SF	C-3	2 1/32	2 1/16
33.50	33.45	3-3V3350SF	SF	C-3	1/4	2 1/16	4-3V3350E	E	C-3	9/32	2 3/4

*Suffix on Type indicates construction:
 1 = Solid 2 = Web 3 = Arm/Spoke

Order bushings separately from pages 30-31.

Sheaves are precision machined from gray cast iron, statically balanced, painted with baked enamel finish and individually packaged.

Heavy Duty Five, Six, Eight and Ten Groove 3V QD[®] Sheaves

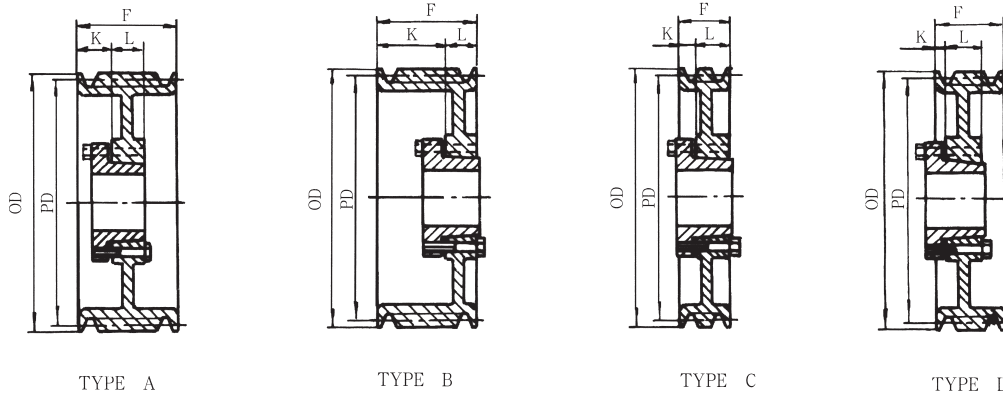

Diameters		5 Groove F = 2 ⁵ / ₁₆					6 Groove F = 2 ²³ / ₃₂				
O.D.	P.D.	Part No.	Bush	Type*	K	L	Part No.	Bush	Type*	K	L
4.75	4.70	5-3V475SDS	SDS	A-1	1 ³ / ₁₆	1 ⁵ / ₁₆	6-3V475SK	SK	D-1	1/8	1 ¹⁵ / ₁₆
5.00	4.95	5-3V500SDS	SDS	A-1	1 ³ / ₁₆	1 ⁵ / ₁₆	6-3V500SK	SK	D-1	1/8	1 ¹⁵ / ₁₆
5.30	5.25	5-3V530SK	SK	A-1	1 ⁵ / ₁₆	1 ¹⁵ / ₁₆	6-3V530SK	SK	A-1	1 ⁵ / ₁₆	1 ¹⁵ / ₁₆
5.60	5.55	5-3V560SK	SK	A-1	1 ⁵ / ₁₆	1 ¹⁵ / ₁₆	6-3V560SK	SK	A-1	1 ⁵ / ₁₆	1 ¹⁵ / ₁₆
6.00	5.95	5-3V600SK	SK	A-1	1 ⁵ / ₁₆	1 ¹⁵ / ₁₆	6-3V600SK	SK	A-1	1 ⁵ / ₁₆	1 ¹⁵ / ₁₆
6.50	6.45	5-3V650SK	SK	A-1	1 ⁵ / ₁₆	1 ¹⁵ / ₁₆	6-3V650SK	SK	A-1	1 ⁵ / ₁₆	1 ¹⁵ / ₁₆
6.90	6.85	5-3V690SK	SK	A-2	1 ⁵ / ₁₆	1 ¹⁵ / ₁₆	6-3V690SK	SK	A-2	1 ⁵ / ₁₆	1 ¹⁵ / ₁₆
8.00	7.95	5-3V800SK	SK	A-2	1 ⁵ / ₁₆	1 ¹⁵ / ₁₆	6-3V800SK	SK	A-2	1 ⁵ / ₁₆	1 ¹⁵ / ₁₆
10.60	10.55	5-3V1060SK	SK	A-3	1 ⁵ / ₁₆	1 ¹⁵ / ₁₆	6-3V1060SF	SF	A-2	7/8	2 ¹ / ₁₆
14.00	13.95	5-3V1400SF	SF	A-3	7/8	2 ¹ / ₁₆	6-3V1400SF	SF	A-3	7/8	2 ¹ / ₁₆
19.00	18.95	5-3V1900SF	SF	A-3	7/8	2 ¹ / ₁₆	6-3V1900E	E	B-3	1 ³ / ₃₂	2 ³ / ₄
25.00	24.95	5-3V2500E	E	C-3	1 ¹ / ₁₆	2 ³ / ₄	6-3V2500E	E	B-3	1 ³ / ₃₂	2 ³ / ₄
33.50	33.45	5-3V3350E	E	C-3	1 ¹ / ₁₆	2 ³ / ₄	6-3V3350E	E	B-3	1 ³ / ₃₂	2 ³ / ₄
Diameters		8 Groove F = 3 ¹⁷ / ₃₂					10 Groove F = 4 ¹¹ / ₃₂				
O.D.	P.D.	Part No.	Bush	Type*	K	L	Part No.	Bush	Type*	K	L
4.75	4.70	8-3V475SK	SK	D-1	1/8	1 ¹⁵ / ₁₆	10-3V475SK	SK	D-1	1/8	1 ¹⁵ / ₁₆
5.00	4.95	8-3V500SK	SK	D-1	1/8	1 ¹⁵ / ₁₆	10-3V500SK	SK	D-1	1/8	1 ¹⁵ / ₁₆
5.30	5.25	8-3V530SK	SK	A-1	1 ⁵ / ₁₆	1 ¹⁵ / ₁₆	10-3V530SK	SK	A-1	1 ⁷ / ₁₆	1 ¹⁵ / ₁₆
5.60	5.55	8-3V560SK	SK	A-1	1 ⁵ / ₁₆	1 ¹⁵ / ₁₆	10-3V560SK	SK	A-1	1 ⁷ / ₁₆	1 ¹⁵ / ₁₆
6.00	5.95	8-3V600SK	SK	A-1	1 ⁵ / ₁₆	1 ¹⁵ / ₁₆	10-3V600SK	SK	A-1	1 ⁷ / ₁₆	1 ¹⁵ / ₁₆
6.50	6.45	8-3V650SK	SK	A-1	1 ⁵ / ₁₆	1 ¹⁵ / ₁₆	10-3V650SK	SK	A-1	1 ⁷ / ₁₆	1 ¹⁵ / ₁₆
6.90	6.85	8-3V690SK	SK	A-2	1 ⁵ / ₁₆	1 ¹⁵ / ₁₆	10-3V690SK	SK	A-2	1 ⁷ / ₁₆	1 ¹⁵ / ₁₆
8.00	7.95	8-3V800SF	SF	A-2	1 ¹ / ₈	2 ¹ / ₁₆	10-3V800SF	SF	A-2	1 ¹ / ₂	2 ¹ / ₁₆
10.60	10.55	8-3V1060SF	SF	A-3	1 ¹ / ₈	2 ¹ / ₁₆	10-3V1060E	E	A-2	1 ¹ / ₄	2 ³ / ₄
14.00	13.95	8-3V1400E	E	A-3	1 ¹ / ₄	2 ³ / ₄	10-3V1400E	E	A-3	1 ¹ / ₄	2 ³ / ₄
19.00	18.95	8-3V1900E	E	A-3	1 ¹ / ₄	2 ³ / ₄	10-3V1900E	E	A-3	1 ¹ / ₄	2 ³ / ₄
25.00	24.95	8-3V2500E	E	A-3	1 ¹ / ₄	2 ³ / ₄	10-3V2500F	F	A-3	1 ⁵ / ₁₆	3 ³ / ₄
33.50	33.45	8-3V3350F	F	B-3	1 ¹ / ₃₂	3 ³ / ₄	10-3V3350F	F	A-3	1 ⁵ / ₁₆	3 ³ / ₄

*Suffix on Type indicates construction:
 1 = Solid 2 = Web 3 = Arm/Spoke

Order bushings separately from pages 30-31.

Sheaves are precision machined from gray cast iron, statically balanced, painted with baked enamel finish and individually packaged.

Heavy Duty Two and Three Groove 5V QD[®] Sheaves

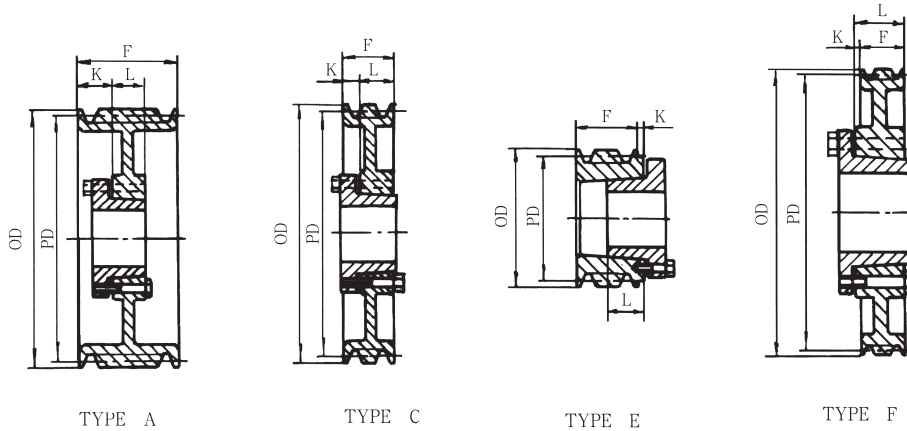

Diameters		2 Groove F = 1 11/16					3 Groove F = 2 3/8				
O.D.	P.D.	Part No.	Bush	Type*	K	L	Part No.	Bush	Type*	K	L
4.40	4.30	2-5V440SH	SH	A-1	1 1/16	1 5/16	3-5V440SDS	SDS	E-1	0	1 5/16
4.65	4.55	2-5V465SDS	SDS	E-1	3/16	1 5/16	3-5V465SDS	SDS	E-1	0	1 5/16
4.90	4.80	2-5V490SDS	SDS	A-1	1 1/16	1 5/16	3-5V490SDS	SDS	A-1	1 1/16	1 5/16
5.20	5.10	2-5V520SDS	SDS	A-1	1 1/16	1 5/16	3-5V520SDS	SDS	A-1	1 1/16	1 5/16
5.50	5.40	2-5V550SDS	SDS	A-1	1 1/16	1 5/16	3-5V550SDS	SDS	A-1	1 1/16	1 5/16
5.90	5.80	2-5V590SDS	SDS	A-1	1 1/16	1 5/16	3-5V590SDS	SDS	A-1	1 1/16	1 5/16
6.30	6.20	2-5V630SK	SK	C-1	7/16	1 15/16	3-5V630SK	SK	A-1	1 1/16	1 15/16
6.70	6.60	2-5V670SK	SK	C-1	7/16	1 15/16	3-5V670SK	SK	A-1	1 1/8	1 15/16
7.10	7.00	2-5V710SK	SK	C-1	7/16	1 15/16	3-5V710SF	SF	A-1	1 1/8	2 1/16
7.50	7.40	2-5V750SK	SK	C-1	7/16	1 15/16	3-5V750SF	SF	A-1	1 1/8	2 1/16
8.00	7.90	2-5V800SK	SK	C-2	7/16	1 15/16	3-5V800SF	SF	A-1	1 1/8	2 1/16
8.50	8.40	2-5V850SK	SK	C-2	7/16	1 15/16	3-5V850SF	SF	A-2	1 1/8	2 1/16
9.00	8.90	2-5V900SK	SK	C-2	7/16	1 15/16	3-5V900SF	SF	A-2	1 1/8	2 1/16
9.25	9.15	2-5V925SK	SK	C-2	7/16	1 15/16	3-5V925SF	SF	A-2	1 1/8	2 1/16
9.75	9.65	2-5V975SK	SK	C-3	7/16	1 15/16	3-5V975SF	SF	A-2	1 1/8	2 1/16
10.30	10.20	2-5V1030SK	SK	C-3	7/16	1 15/16	3-5V1030SF	SF	A-2	1 1/8	2 1/16
10.90	10.80	2-5V1090SK	SK	C-3	7/16	1 15/16	3-5V1090SF	SF	A-2	1 1/8	2 1/16
11.30	11.20	2-5V1130SK	SK	C-3	7/16	1 15/16	3-5V1130SF	SF	A-3	1 1/8	2 1/16
11.80	11.70	2-5V1180SK	SK	C-3	7/16	1 15/16	3-5V1180SF	SF	A-3	1 1/8	2 1/16
12.50	12.40	2-5V1250SK	SK	C-3	7/16	1 15/16	3-5V1250E	E	C-3	3/4	2 3/4
13.20	13.10	2-5V1320SF	SF	C-3	7/16	2 1/16	3-5V1320E	E	C-3	3/4	2 3/4
14.00	13.90	2-5V1400SF	SF	C-3	7/16	2 1/16	3-5V1400E	E	C-3	3/4	2 3/4
15.00	14.90	2-5V1500SF	SF	C-3	7/16	2 1/16	3-5V1500E	E	C-3	3/4	2 3/4
16.00	15.90	2-5V1600SF	SF	C-3	7/16	2 1/16	3-5V1600E	E	C-3	3/4	2 3/4
18.70	18.60	2-5V1870SF	SF	C-3	7/16	2 1/16	3-5V1870E	E	C-3	3/4	2 3/4
21.20	21.10	2-5V2120SF	SF	C-3	7/16	2 1/16	3-5V2120E	E	C-3	3/4	2 3/4
23.60	23.50	2-5V2360E	E	C-3	1/16	2 3/4	3-5V2360E	E	C-3	3/4	2 3/4
28.00	27.90	2-5V2800E	E	C-3	1/16	2 3/4	3-5V2800E	E	C-3	3/4	2 3/4
31.50	31.40						3-5V3150F	F	F-3	1/8	3 3/4
37.50	37.40						3-5V3750F	F	F-3	1/8	3 3/4
50.00	49.90						3-5V5000F	F	F-3	1/8	3 3/4

*Suffix on Type indicates construction:
 1 = Solid 2 = Web 3 = Arm/Spoke

Order bushings separately from pages 30-31.

Sheaves are precision machined from gray cast iron, statically balanced, painted with baked enamel finish and individually packaged.

Heavy Duty Four and Five Groove 5V QD[®] Sheaves

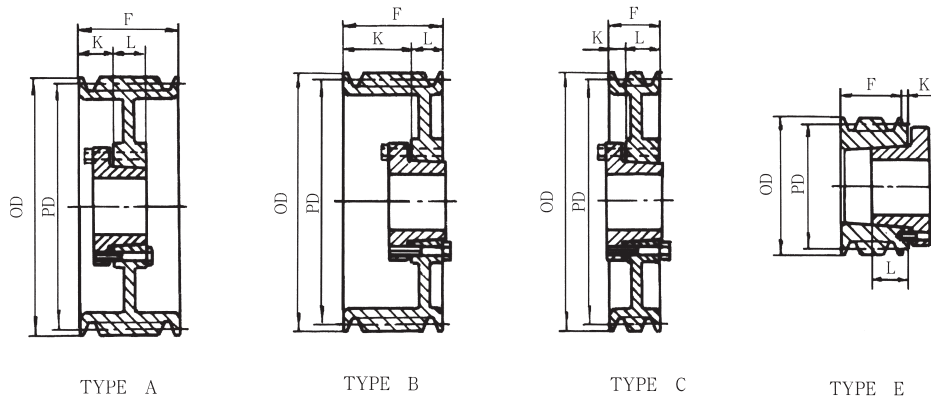

Diameters		4 Groove F = 3 1/16					5 Groove F = 3 3/4				
O.D.	P.D.	Part No.	Bush	Type*	K	L	Part No.	Bush	Type*	K	L
4.40	4.30	4-5V440SD	SD	E-1	0	1 13/16	5-5V440SD	SD	E-1	0	1 13/16
4.65	4.55	4-5V465SD	SD	E-1	0	1 13/16	5-5V465SD	SD	E-1	0	1 13/16
4.90	4.80	4-5V490SD	SD	A-1	1 5/16	1 13/16	5-5V490SD	SD	A-1	1 5/16	1 13/16
5.20	5.10	4-5V520SD	SD	A-1	1 5/16	1 13/16	5-5V520SD	SD	A-1	1 5/16	1 13/16
5.50	5.40	4-5V550SD	SD	A-1	1 5/16	1 13/16	5-5V550SD	SD	A-1	1 5/16	1 13/16
5.90	5.80	4-5V590SD	SD	A-1	1 5/16	1 13/16	5-5V590SK	SK	A-1	1 5/16	1 15/16
6.30	6.20	4-5V630SK	SK	A-1	1 5/16	1 19/16	5-5V630SK	SK	A-1	1 5/16	1 15/16
6.70	6.60	4-5V670SK	SK	A-1	1 5/16	1 19/16	5-5V670SF	SF	A-1	1 3/8	2 1/16
7.10	7.00	4-5V710SF	SF	A-1	1 1/16	2 1/16	5-5V710SF	SF	A-1	1 3/8	2 1/16
7.50	7.40	4-5V750SF	SF	A-1	1 1/16	2 1/16	5-5V750SF	SF	A-1	1 3/8	2 1/16
8.00	7.90	4-5V800E	E	B-1	1 7/16	2 3/4	5-5V800E	E	A-1	1 3/4	2 3/4
8.50	8.40	4-5V850E	E	B-1	1 7/16	2 3/4	5-5V850E	E	A-1	1 3/4	2 3/4
9.00	8.90	4-5V900E	E	B-1	1 7/16	2 3/4	5-5V900E	E	A-1	1 3/4	2 3/4
9.25	9.15	4-5V925E	E	B-1	1 7/16	2 3/4	5-5V925E	E	A-1	1 3/4	2 3/4
9.75	9.65	4-5V975E	E	B-2	1 7/16	2 3/4	5-5V975E	E	A-2	1 3/4	2 3/4
10.30	10.20	4-5V1030E	E	B-2	1 7/16	2 3/4	5-5V1030E	E	A-2	1 3/4	2 3/4
10.90	10.80	4-5V1090E	E	B-2	1 7/16	2 3/4	5-5V1090E	E	A-2	1 3/4	2 3/4
11.30	11.20	4-5V1130E	E	B-2	1 7/16	2 3/4	5-5V1130E	E	A-2	1 3/4	2 3/4
11.80	11.70	4-5V1180E	E	B-2	1 7/16	2 3/4	5-5V1180E	E	A-2	1 3/4	2 3/4
12.50	12.40	4-5V1250E	E	B-3	1 7/16	2 3/4	5-5V1250E	E	A-3	1 3/4	2 3/4
13.20	13.10	4-5V1320E	E	B-3	1 7/16	2 3/4	5-5V1320E	E	A-3	1 3/4	2 3/4
14.00	13.90	4-5V1400E	E	B-3	1 7/16	2 3/4	5-5V1400E	E	A-3	1 3/4	2 3/4
15.00	14.90	4-5V1500E	E	B-3	1 7/16	2 3/4	5-5V1500E	E	A-3	1 3/4	2 3/4
16.00	15.90	4-5V1600E	E	B-3	1 7/16	2 3/4	5-5V1600E	E	A-3	1 3/4	2 3/4
18.70	18.60	4-5V1870E	E	A-3	1 1/4	2 3/4	5-5V1870F	F	B-3	1 1/4	3 3/4
21.20	21.10	4-5V2120E	E	A-3	1 1/4	2 3/4	5-5V2120F	F	B-3	1 1/4	3 3/4
23.60	23.50	4-5V2360F	F	C-3	7/8	3 3/4	5-5V2360F	F	B-3	1 1/4	3 3/4
28.00	27.90	4-5V2800F	F	C-3	7/8	3 3/4	5-5V2800F	F	B-3	1 1/4	3 3/4
31.50	31.40	4-5V3150F	F	C-3	7/8	3 3/4	5-5V3150J	J	C-3	9/16	4 5/8
37.50	37.40	4-5V3750F	F	C-3	7/8	3 3/4	5-5V3750J	J	C-3	9/16	4 5/8
50.00	45.90	4-5V5000J	J	B-3	1/8	4 5/8	5-5V5000J	J	C-3	9/16	4 5/8

*Suffix on Type indicates construction:
1 = Solid 2 = Web 3 = Arm/Spoke

Order bushings separately from pages 30-31.

Sheaves are precision machined from gray cast iron, statically balanced, painted with baked enamel finish and individually packaged.

Heavy Duty Six and Eight Groove 5V QD® Sheaves

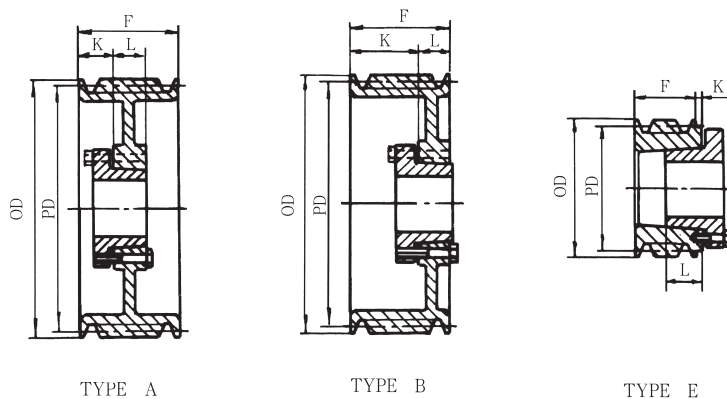

Diameters		6 Groove F = 4 ⁷ / ₁₆					8 Groove F = 5 ¹³ / ₁₆				
O.D.	P.D.	Part No.	Bush	Type*	K	L	Part No.	Bush	Type*	K	L
4.40	4.30	6-5V440SD	SD	E-1	0	1 ¹³ / ₁₆					
4.65	4.55	6-5V465SD	SD	E-1	0	1 ¹³ / ₁₆					
4.90	4.80	6-5V490SD	SD	A-1	1 ⁵ / ₁₆	1 ¹³ / ₁₆					
5.20	5.10	6-5V520SD	SD	A-1	1 ⁵ / ₁₆	1 ¹³ / ₁₆					
5.50	5.40	6-5V550SD	SD	A-1	1 ⁵ / ₁₆	1 ¹³ / ₁₆					
5.90	5.80	6-5V590SK	SK	A-1	1 ⁵ / ₁₆	1 ¹⁵ / ₁₆					
6.30	6.20	6-5V630SK	SK	A-1	1 ⁵ / ₁₆	1 ¹⁵ / ₁₆					
6.70	6.60	6-5V670SF	SF	A-1	1 ⁵ / ₈	2 ¹ / ₁₆					
7.10	7.00	6-5V710SF	SF	A-1	1 ⁵ / ₈	2 ¹ / ₁₆	8-5V710SF	SF	A-1	2 ¹ / ₈	2 ¹ / ₁₆
7.50	7.40	6-5V750SF	SF	A-1	1 ⁵ / ₈	2 ¹ / ₁₆	8-5V750SF	SF	A-1	2 ¹ / ₈	2 ¹ / ₁₆
8.00	7.90	6-5V800E	E	A-1	2	2 ³ / ₄	8-5V800E	E	A-1	2 ¹ / ₂	2 ³ / ₄
8.50	8.40	6-5V850E	E	A-1	2	2 ³ / ₄	8-5V850E	E	A-1	2 ¹ / ₂	2 ³ / ₄
9.00	8.90	6-5V900E	E	A-1	2	2 ³ / ₄	8-5V900E	E	A-1	2 ¹ / ₂	2 ³ / ₄
9.25	9.15	6-5V925E	E	A-1	2	2 ³ / ₄	8-5V925F	F	A-1	2 ⁹ / ₁₆	3 ³ / ₄
9.75	9.65	6-5V975E	E	A-2	2	2 ³ / ₄	8-5V975F	F	A-1	2 ⁹ / ₁₆	3 ³ / ₄
10.30	10.20	6-5V1030E	E	A-2	2	2 ³ / ₄	8-5V1030F	F	A-1	2 ⁹ / ₁₆	3 ³ / ₄
10.90	10.80	6-5V1090E	E	A-2	2	2 ³ / ₄	8-5V1090F	F	A-2	2 ⁹ / ₁₆	3 ³ / ₄
11.30	11.20	6-5V1130E	E	A-2	2	2 ³ / ₄	8-5V1130F	F	A-2	2 ⁹ / ₁₆	3 ³ / ₄
11.80	11.70	6-5V1180E	E	A-2	2	2 ³ / ₄	8-5V1180F	F	A-2	2 ⁹ / ₁₆	3 ³ / ₄
12.50	12.40	6-5V1250F	F	B-3	1 ⁵ / ₁₆	3 ³ / ₄	8-5V1250F	F	A-2	2 ⁹ / ₁₆	3 ³ / ₄
13.20	13.10	6-5V1320F	F	B-3	1 ⁵ / ₁₆	3 ³ / ₄	8-5V1320F	F	A-3	2 ⁹ / ₁₆	3 ³ / ₄
14.00	13.90	6-5V1400F	F	B-3	1 ⁵ / ₁₆	3 ³ / ₄	8-5V1400F	F	A-3	2 ⁹ / ₁₆	3 ³ / ₄
15.00	14.90	6-5V1500F	F	B-3	1 ⁵ / ₁₆	3 ³ / ₄	8-5V1500F	F	A-3	2 ⁹ / ₁₆	3 ³ / ₄
16.00	15.90	6-5V1600F	F	B-3	1 ⁵ / ₁₆	3 ³ / ₄	8-5V1600F	F	A-3	2 ⁹ / ₁₆	3 ³ / ₄
18.70	18.60	6-5V1870F	F	A-3	1 ⁵ / ₁₆	3 ³ / ₄	8-5V1870J	J	A-3	1 ⁹ / ₁₆	4 ⁵ / ₈
21.20	21.10	6-5V2120F	F	A-3	1 ¹⁵ / ₁₆	3 ³ / ₄	8-5V2120J	J	A-3	1 ⁹ / ₁₆	4 ⁵ / ₈
23.60	23.50	6-5V2360J	J	B-3	1 ¹ / ₄	4 ⁹ / ₈	8-5V2360J	J	A-3	1 ⁹ / ₁₆	4 ⁵ / ₈
28.00	27.90	6-5V2800J	J	B-3	1 ¹ / ₄	4 ⁹ / ₈	8-5V2800J	J	A-3	1 ⁹ / ₁₆	4 ⁵ / ₈
31.50	31.40	6-5V3150J	J	B-3	1 ¹ / ₄	4 ⁹ / ₈	8-5V3150M	M	B-3	5 ⁸ / ₈	6 ³ / ₄
37.50	37.40	6-5V3750J	J	B-3	1 ¹ / ₄	4 ⁹ / ₈	8-5V3750M	M	B-3	5 ⁸ / ₈	6 ³ / ₄
50.00	45.50	6-5V5000M	M	C-3	3 ⁴ / ₄	6 ³ / ₄	8-5V5000M	M	B-3	5 ⁸ / ₈	6 ³ / ₄

*Suffix on Type indicates construction:
 1 = Solid 2 = Web 3 = Arm/Spoke

Order bushings separately from pages 30-31.

Sheaves are precision machined from gray cast iron, statically balanced, painted with baked enamel finish and individually packaged.

Heavy Duty Ten Groove 5V QD[®] Sheaves

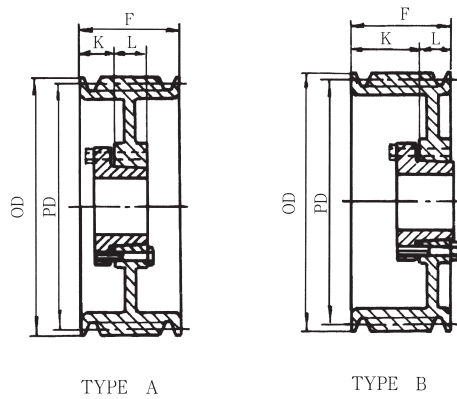

Diameters		10 Groove F = 7 ³ / ₁₆				
O.D.	P.D.	Part No.	Bush	Type*	K	L
8.00	7.90	10-5V800E	E	A-1	3 ¹ / ₄	2 ³ / ₄
8.50	8.40	10-5V850E	E	A-1	3 ¹ / ₄	2 ³ / ₄
9.00	8.90	10-5V900F	F	A-1	3 ⁵ / ₁₆	3 ³ / ₄
9.25	9.15	10-5V925F	F	A-1	3 ⁵ / ₁₆	3 ³ / ₄
9.75	9.65	10-5V975F	F	A-1	3 ⁵ / ₁₆	3 ³ / ₄
10.30	10.20	10-5V1030F	F	A-1	3 ⁵ / ₁₆	3 ³ / ₄
10.90	10.80	10-5V1090F	F	A-2	3 ⁵ / ₁₆	3 ³ / ₄
11.30	11.20	10-5V1130F	F	A-2	3 ⁵ / ₁₆	3 ³ / ₄
11.80	11.70	10-5V1180F	F	A-2	3 ⁵ / ₁₆	3 ³ / ₄
12.50	12.40	10-5V1250J	J	A-2	3 ⁹ / ₁₆	4 ⁵ / ₈
13.20	13.10	10-5V1320J	J	A-2	3 ⁹ / ₁₆	4 ⁵ / ₈
14.00	13.90	10-5V1400J	J	A-2	3 ⁹ / ₁₆	4 ⁵ / ₈
15.00	14.90	10-5V1500J	J	A-2	3 ⁹ / ₁₆	4 ⁵ / ₈
16.00	15.90	10-5V1600J	J	A-3	3 ⁹ / ₁₆	4 ⁵ / ₈
18.70	18.60	10-5V1870J	J	A-3	1 ⁹ / ₁₆	4 ⁵ / ₈
21.20	21.10	10-5V2120J	J	A-3	1 ⁹ / ₁₆	4 ⁵ / ₈
23.60	23.50	10-5V2360M	M	B-3	1 ¹⁵ / ₁₆	6 ³ / ₄
28.00	27.90	10-5V2800M	M	B-3	1 ¹⁵ / ₁₆	6 ³ / ₄
31.50	31.40	10-5V3150M	M	B-3	1 ¹⁵ / ₁₆	6 ³ / ₄
37.50	37.40	10-5V3750M	M	B-3	1 ¹⁵ / ₁₆	6 ³ / ₄
50.00	49.40	10-5V5000M	M	B-3	1 ¹⁵ / ₁₆	6 ³ / ₄

*Suffix on Type indicates construction:
 1 = Solid 2 = Web 3 = Arm/Spoke

Order bushings separately from pages 30-31.

Sheaves are precision machined from gray cast iron, statically balanced, painted with baked enamel finish and individually packaged.

Heavy Duty Four, Five, Six & Eight Groove 8V QD® Sheaves

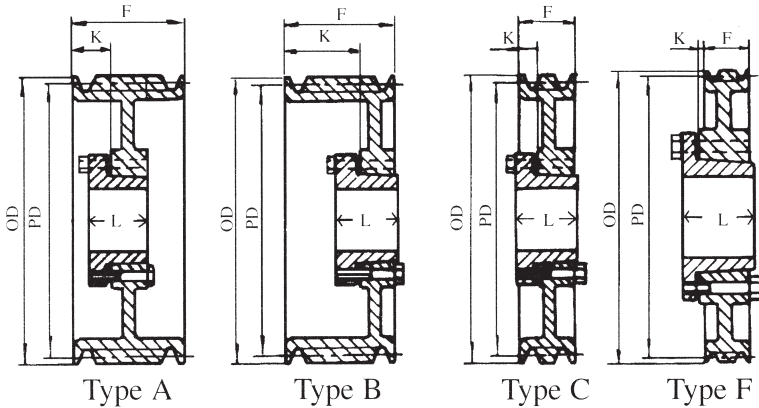

Diameters		4 Groove F = 4 ⁷ / ₈					5 Groove F = 6				
O.D.	P.D.	Part No.	Bush	Type*	K	L	Part No.	Bush	Type*	K	L
12.50	12.30	4-8V1250F	F	A-1	1 ³ / ₁₆	3 ³ / ₄	5-8V1250F	F	A-1	2 ⁵ / ₁₆	3 ³ / ₄
13.20	13.00	4-8V1320F	F	A-2	1 ³ / ₁₆	3 ³ / ₄	5-8V1320F	F	A-2	2 ⁵ / ₁₆	3 ³ / ₄
14.00	13.80	4-8V1400F	F	A-2	1 ³ / ₁₆	3 ³ / ₄	5-8V1400F	F	A-2	2 ⁵ / ₁₆	3 ³ / ₄
15.00	14.80	4-8V1500F	F	A-2	1 ³ / ₁₆	3 ³ / ₄	5-8V1500F	F	A-2	2 ⁵ / ₁₆	3 ³ / ₄
16.00	15.80	4-8V1600F	F	A-2	1 ³ / ₁₆	3 ³ / ₄	5-8V1600F	F	A-2	2 ⁵ / ₁₆	3 ³ / ₄
17.00	16.80	4-8V1700F	F	A-3	1 ³ / ₁₆	3 ³ / ₄	5-8V1700J	J	A-3	2	4 ⁵ / ₈
18.00	17.80	4-8V1800F	F	A-3	1 ³ / ₁₆	3 ³ / ₄	5-8V1800J	J	A-3	2	4 ⁵ / ₈
19.00	18.80	4-8V1900F	F	A-3	1 ³ / ₁₆	3 ³ / ₄	5-8V1900J	J	A-3	2	4 ⁵ / ₈
20.00	19.80	4-8V2000J	J	A-3	1 ⁷ / ₁₆	4 ⁵ / ₈	5-8V2000J	J	A-3	2	4 ⁵ / ₈
21.20	21.00	4-8V2120J	J	A-3	1 ⁷ / ₁₆	4 ⁵ / ₈	5-8V2120J	J	A-3	2	4 ⁵ / ₈
22.40	22.20	4-8V2240J	J	A-3	1 ⁷ / ₁₆	4 ⁵ / ₈	5-8V2240M	M	B-3	1 ³ / ₁₆	6 ³ / ₄
24.80	24.60	4-8V2480M	M	F-3	5 ¹ / ₁₆	6 ³ / ₄	5-8V2480M	M	B-3	1 ³ / ₁₆	6 ³ / ₄
30.00	29.80	4-8V3000M	M	F-3	5 ¹ / ₁₆	6 ³ / ₄	5-8V3000M	M	B-3	1 ³ / ₁₆	6 ³ / ₄
35.50	35.30	4-8V3550M	M	F-3	5 ¹ / ₁₆	6 ³ / ₄	5-8V3550M	M	B-3	1 ³ / ₁₆	6 ³ / ₄
40.00	39.80	4-8V4000M	M	F-3	5 ¹ / ₁₆	6 ³ / ₄	5-8V4000M	M	B-3	1 ³ / ₁₆	6 ³ / ₄
Diameters		6 Groove F = 7 ¹ / ₈					8 Groove F = 9 ³ / ₈				
O.D.	P.D.	Part No.	Bush	Type*	K	L	Part No.	Bush	Type*	K	L
12.50	12.30	6-8V1250F	F	A-1	2 ⁵ / ₁₆	3 ³ / ₄	8-8V1250J	J	A-1	3 ⁹ / ₁₆	4 ⁵ / ₈
13.20	13.00	6-8V1320F	F	A-1	2 ⁵ / ₁₆	3 ³ / ₄	8-8V1320J	J	A-1	3 ⁹ / ₁₆	4 ⁵ / ₈
14.00	13.80	6-8V1400F	F	A-1	2 ⁵ / ₁₆	3 ³ / ₄	8-8V1400J	J	A-1	3 ⁹ / ₁₆	4 ⁵ / ₈
15.00	14.80	6-8V1500J	J	A-1	2 ⁹ / ₁₆	4 ⁵ / ₈	8-8V1500J	J	A-1	3 ⁹ / ₁₆	4 ⁵ / ₈
16.00	15.80	6-8V1600J	J	A-1	2 ⁹ / ₁₆	4 ⁵ / ₈	8-8V1600J	J	A-1	3 ⁹ / ₁₆	4 ⁵ / ₈
17.00	16.80	6-8V1700J	J	A-2	2 ⁹ / ₁₆	4 ⁵ / ₈	8-8V1700M	M	A-2	3 ¹⁵ / ₁₆	6 ³ / ₄
18.00	17.80	6-8V1800J	J	A-2	2 ⁹ / ₁₆	4 ⁵ / ₈	8-8V1800M	M	A-2	3 ¹⁵ / ₁₆	6 ³ / ₄
19.00	18.80	6-8V1900J	J	A-2	2 ⁹ / ₁₆	4 ⁵ / ₈	8-8V1900M	M	A-2	3 ¹⁵ / ₁₆	6 ³ / ₄
20.00	19.80	6-8V2000M	M	B-2	1 ⁵ / ₁₆	6 ³ / ₄	8-8V2000M	M	A-2	3 ¹⁵ / ₁₆	6 ³ / ₄
21.20	21.00	6-8V2120M	M	B-2	1 ⁵ / ₁₆	6 ³ / ₄	8-8V2120M	M	A-2	3 ¹⁵ / ₁₆	6 ³ / ₄
22.40	22.20	6-8V2240M	M	B-3	1 ⁵ / ₁₆	6 ³ / ₄	8-8V2240M	M	A-3	3 ¹⁵ / ₁₆	6 ³ / ₄
24.80	24.60	6-8V2480M	M	B-3	1 ¹⁵ / ₁₆	6 ³ / ₄	8-8V2480N	N	A-3	2 ¹ / ₄	8 ¹ / ₈
30.00	29.80	6-8V3000M	M	B-3	1 ¹⁵ / ₁₆	6 ³ / ₄	8-8V3000N	N	A-3	2 ¹ / ₄	8 ¹ / ₈
35.50	35.30	6-8V3550N	N	C-3	1 ¹ / ₈	8 ¹ / ₈	8-8V3550N	N	A-3	2 ¹ / ₄	8 ¹ / ₈
40.00	39.80	6-8V4000N	N	C-3	1 ¹ / ₈	8 ¹ / ₈	8-8V4000N	N	A-3	2 ¹ / ₄	8 ¹ / ₈

*Suffix on Type indicates construction:
 1 = Solid 2 = Web 3 = Arm/Spoke

Order bushings separately from pages 30-31.

Sheaves are precision machined from gray cast iron, statically balanced, painted with baked enamel finish and individually packaged.

Heavy Duty Ten Groove 8V QD[®] Sheaves

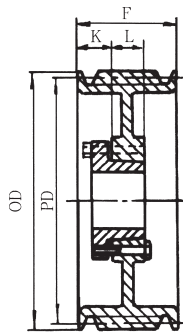

TYPE A



Diameters		10 Groove F = 13 ⁷ / ₈				
O.D.	P.D.	Part No.	Bush	Type*	K	L
12.50	12.30	10-8V1250J	J	A-1	3 ⁹ / ₁₆	4 ⁵ / ₈
13.20	13.00	10-8V1320J	J	A-1	3 ⁹ / ₁₆	4 ⁵ / ₈
14.00	13.80	10-8V1400J	J	A-1	3 ⁹ / ₁₆	6 ³ / ₄
15.00	14.80	10-8V1500M	M	A-1	3 ¹⁵ / ₁₆	6 ³ / ₄
16.00	15.80	10-8V1600M	M	A-2	3 ¹⁵ / ₁₆	6 ³ / ₄
17.00	16.80	10-8V1700M	M	A-2	3 ¹⁵ / ₁₆	6 ³ / ₄
18.00	17.80	10-8V1800M	M	A-2	3 ¹⁵ / ₁₆	6 ³ / ₄
19.00	18.80	10-8V1900M	M	A-2	3 ¹⁵ / ₁₆	6 ³ / ₄
20.00	19.80	10-8V2000M	M	A-2	3 ¹⁵ / ₁₆	6 ³ / ₄
21.20	21.00	10-8V2120M	M	A-2	3 ¹⁵ / ₁₆	6 ³ / ₄
22.40	22.20	10-8V2240N	N	A-2	2 ¹ / ₄	8 ¹ / ₈
24.80	24.60	10-8V2480N	N	A-2	2 ¹ / ₄	8 ¹ / ₈
30.00	29.80	10-8V3000N	N	A-2	2 ¹ / ₄	8 ¹ / ₈

*Suffix on Type indicates construction:
 1 = Solid 2 = Web 3 = Arm/Spoke

Order bushings separately from pages 30-31.

Sheaves are precision machined from gray cast iron, statically balanced, painted with baked enamel finish and individually packaged.

LIGHT DUTY SHEAVES 1VL & AL

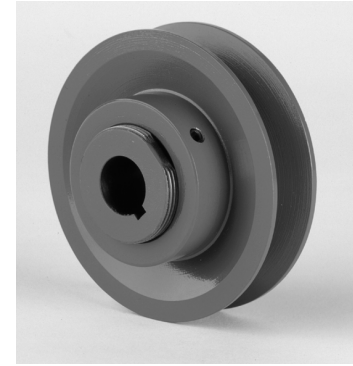
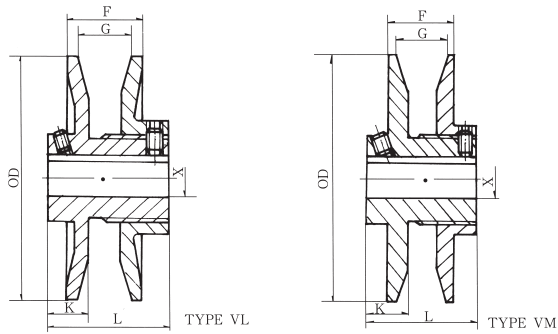

Part No.	Dimensions (in.)							Stock Bores (in.)
	O.D.	F		G		L	K	
		Max.	Min.	Max.	Min.			
1VL25	2.50	25/32	17/32	5/8	3/8	1 1/2	37/64	1/2, 5/8
1VL30	2.87	25/32	17/32	5/8	3/8	1 1/2	37/64	1/2, 5/8
1VL34	3.15	1	5/8	7/8	1/2	1 11/16	37/64	1/2, 5/8, 3/4
1VL40	3.75	1	5/8	7/8	1/2	1 11/16	37/64	1/2, 5/8, 3/4, 7/8
1VL44	4.15	1	5/8	7/8	1/2	1 11/16	37/64	1/2, 5/8, 3/4, 7/8
1VM50	4.75	1 1/16	1 1/16	7/8	1/2	1 7/8	21/32	1/2, 5/8, 3/4, 7/8

Cast Iron Sheaves - Light Duty

Bored to Size

One Groove

AL Sheaves

Order Part number size

Example: no keyway = AL54-5/8, with keyway = AL54-5/8KW

AL Sheaves may be used with 3L, 4L, and A Belts

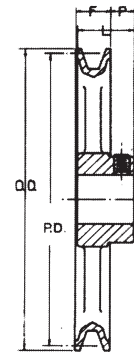

AL Sheaves come with or without Keyway and are for Light Applications - Fans, Air Conditioning Units, Furnace Blowers, etc.

Part No	O.D.	Pitch	F	L	P	Stock Bores (in.)	Hub O.D.	Average Wt.
AL54	4.93	4.78	.593	1.062	.468	5/8, 3/4, 1	1.7	1.2
AL64	5.93	5.78	.593	1.062	.468	5/8, 3/4, 1	1.7	1.4
AL74	6.93	6.78	.593	1.062	.468	5/8, 3/4, 1	1.7	1.7
AL84	7.93	7.78	.593	1.062	.468	5/8, 3/4, 1	1.7	1.9
AL94	8.93	8.78	.593	1.062	.468	3/4, 1	1.9	2.6
AL104	9.93	9.78	.593	1.062	.468	3/4, 1	2.0	3.0
AL114	10.93	10.78	.593	1.062	.468	3/4, 1	2.0	3.5
AL124	11.93	11.78	.593	1.062	.468	3/4, 1	2.0	4.0
AM144	14.16	14.00	6.87	1.750	.406	1	2.0	5.2

VARIABLE PITCH SHEAVES

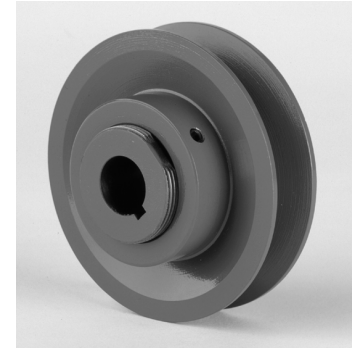
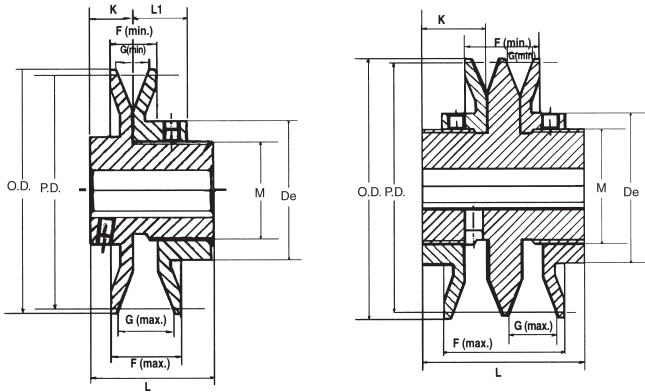

Part No.	Single Groove Dimensions (in.)							Stock Bores (in.)	
	Type	O.D.	F		G		L		K
			Max.	Min.	Max.	Min.			
1VP25	1	2.32	.81	.56	.63	.38	1.59	1.62	1/2, 5/8, 3/4
1VP30	1	2.87	.81	.56	.63	.38	1.66	.63	1/2, 5/8, 3/4
1VP34	1	3.15	1.00	.69	.81	.50	1.88	.78	1/2, 5/8, 3/4, 7/8, 1, 1 1/8
1VP40	1	3.75	1.06	.69	.88	.50	1.88	.66	1/2, 5/8, 3/4, 7/8, 1, 1 1/8
1VP44	1	4.15	1.06	.69	.88	.50	1.88	.66	1/2, 5/8, 3/4, 7/8, 1, 1 1/8
1VP50	1	4.75	1.06	.69	.88	.50	2.00	.78	1/2, 5/8, 3/4, 7/8, 1, 1 1/8
1VP56	1	5.35	1.06	.69	.88	.50	2.00	.78	1/2, 5/8, 3/4, 7/8, 1, 1 1/8
1VP60	1	6.00	1.25	.88	1.031	.66	2.16	.85	5/8, 3/4, 7/8, 1, 1 1/8, 1 3/8, 1 5/8
1VP62	1	5.95	1.13	.75	.88	.50	2.00	.78	5/8, 3/4, 7/8, 1, 1 1/8, 1 1/4, 1 3/8
1VP65	1	6.50	1.25	.88	1.03	.66	2.16	.85	3/4, 7/8, 1 1/8, 1 3/8
1VP68	1	6.55	1.13	.75	.88	.50	2.00	.78	5/8, 3/4, 7/8, 1, 1 1/8, 1 1/4, 1 3/8
1VP71	1	7.10	1.25	.88	1.03	.66	2.16	.85	3/4, 7/8, 1 1/8, 1 3/8, 1 5/8
1VP75	1	7.50	1.25	.88	1.03	.66	2.16	.85	3/4, 7/8, 1 1/8, 1 3/8, 1 5/8

Part No.	Two Groove Dimensions (in.)						Stock Bores (in.)		
	Type	O.D.	F		G			L	K
			Max.	Min.	Max.	Min.			
2VP36	2	3.35	2.00	1.38	.81	.50	3.00	1.19	1/2, 5/8, 3/4, 7/8, 1, 1 1/8
2VP42	2	3.95	2.13	1.38	.88	.50	3.00	1.19	5/8, 3/4, 7/8, 1, 1 1/8
2VP50	2	4.75	2.13	1.38	.88	.50	3.00	1.19	5/8, 3/4, 7/8, 1, 1 1/8
2VP56	2	5.35	2.13	1.38	.88	.50	3.00	1.19	5/8, 3/4, 7/8, 1, 1 1/8
2VP60	2	6.00	2.38	1.63	1.03	.66	3.25	1.25	3/4, 7/8, 1, 1 1/8, 1 3/8, 1 5/8
2VP62	2	5.95	2.13	1.38	.88	.50	3.00	1.19	3/4, 7/8, 1, 1 1/8, 1 3/8, 1 5/8
2VP65	2	6.50	2.38	1.63	1.03	.66	3.25	1.25	3/4, 7/8, 1 1/8, 1 3/8, 1 5/8
2VP68	2	6.55	2.13	1.38	.88	.50	3.00	1.19	3/4, 7/8, 1, 1 1/4, 1 3/8, 1 5/8
2VP71	2	7.10	2.38	1.63	1.03	.66	3.25	1.25	3/4, 7/8, 1 1/8, 1 3/8, 1 5/8
2VP75	2	7.50	2.38	1.63	1.03	.66	3.25	1.25	3/4, 7/8, 1 1/8, 1 3/8, 1 5/8

Bore Range	Keyseat
1/2	None
5/8 - 7/8	3/16 X 3/32

BUSHINGS H AND QD®

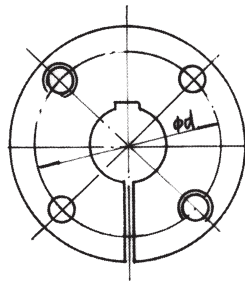

Bushing
H

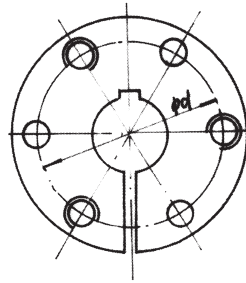

Bushing
JA to J

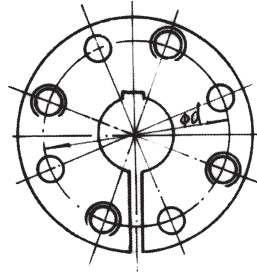

Bushing
M

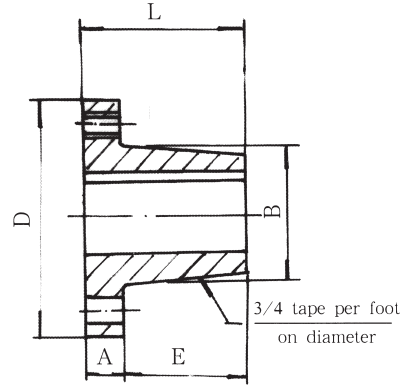

H & QD BUSHINGS – DIMENSIONS (in.)

Bushing	A	B	D	E	L	Φ Bolt Required	Cap Screws Grade 5
H	1/4	1.625	2 1/2	1	1 1/4	2	2 1/4 x 3/4
JA	5/16	1.375	2	1 1/16	1	1.665	3-10 x 1
SH	7/16	1.871	2 11/16	7/8	1 5/16	2 1/4	3 1/4 x 1 3/8
SDS	7/16	2.187	3 1/8	7/8	1 5/16	2 11/16	3 1/4 x 1 3/8
SD	7/16	2.187	3 1/8	1 3/8	1 13/16	2 11/16	3 1/4 x 1 7/8
SK	9/16	2.812	3 7/8	1 3/8	1 15/16	3 5/16	3 5/16 x 2
SF	5/8	3.125	4 5/8	1 7/16	2 1/16	3 7/8	3 3/8 x 2
E	7/8	3.834	6	1 7/8	2 3/4	5	3 1/2 x 2 3/4
F	1	4.437	6 5/8	2 3/4	3 3/4	5 5/8	3 9/16 x 3 5/8
J	1 1/8	5.148	7 1/4	3 1/2	4 5/8	6 1/4	3 5/8 x 4 1/2
M	1 1/4	6.500	9	5 1/2	6 3/4	7 7/8	4 3/4 x 6 3/4



Bushing	Bore Range (in.)	Keyseat (in.)
H	3/8, 7/16, 1/2, 9/16	1/8 x 1/16
	5/8, 1 1/16, 3/4, 13/16, 7/8	3/16 x 3/32
	1 5/16, 1, 1 1/16, 1 1/8, 1 3/16, 1 1/4	1/4 x 1/8
	1 5/16, 1 3/8	5/16 x 1/16*
	1 7/16, 1 1/2	3/8 x 1/16*
JA	7/16, 1/2, 9/16	1/8 x 1/16
	5/8, 1 1/16, 3/4, 13/16, 7/8	3/16 x 3/32
	1 5/16, 1	1/4 x 1/8
	1 1/16, 1 1/8, 1 3/16, 1 1/4	1/4 x 1/16*
		No Key
SH	1/2, 9/16	1/8 x 1/16
	5/8, 1 1/16, 3/4, 13/16, 7/8	3/16 x 3/32
	1 5/16, 1, 1 1/16, 1 1/8, 1 3/16, 1 1/4	1/4 x 1/8
	1 5/16, 1 3/8	5/16 x 5/32
	1 7/16, 1 1/2, 1 9/16, 1 5/8	3/8 x 1/16*
	No Key	
SDS	1/2, 9/16	1/8 x 1/16
	5/8, 1 1/16, 3/4, 13/16, 7/8	3/16 x 3/32
	1 5/16, 1, 1 1/16, 1 1/8, 1 3/16, 1 1/4	1/4 x 1/8
	1 5/16, 1 3/8	5/16 x 5/32
	1 7/16, 1 1/2, 1 9/16, 1 5/8, 1 11/16	3/8 x 3/16
	1 3/4	3/8 x 1/8*
	1 13/16	1/2 x 1/8*
	1 7/8, 1 15/16	1/2 x 1/16*
	No Key	

Bushing	Bore Range (in.)	Keyseat (in.)
SD	1/2, 9/16	1/8 x 1/16
	5/8, 1 1/16, 3/4, 13/16, 7/8	3/16 x 3/32
	1 5/16, 1, 1 1/16, 1 1/8, 1 3/16, 1 1/4	1/4 x 1/8
	1 5/16, 1 3/8	5/16 x 5/32
	1 7/16, 1 1/2, 1 9/16, 1 5/8, 1 11/16	3/8 x 3/16
	1 3/4	3/8 x 1/8*
	1 13/16	1/2 x 1/8*
	1 7/8, 1 15/16	1/2 x 1/16*
	No Key	
SK	1/2, 9/16	1/8 x 1/16
	5/8, 1 1/16, 3/4, 13/16, 7/8	3/16 x 3/32
	1 5/16, 1, 1 1/16, 1 1/8, 1 3/16, 1 1/4	1/4 x 1/8
	1 5/16, 1 3/8	5/16 x 5/32
	1 7/16, 1 1/2, 1 9/16, 1 5/8, 1 11/16, 1 3/4	3/8 x 3/16
	1 13/16, 1 7/8, 1 15/16, 2, 2 1/16, 2 1/8	1/2 x 1/4
	2 3/16, 2 1/4	1/2 x 1/8*
	2 5/16, 2 3/8, 2 7/16, 2 1/2	5/8 x 1/16*
	No Key	
SF	1/2, 9/16	1/8 x 1/16
	5/8, 1 1/16, 3/4, 13/16, 7/8	3/16 x 3/32
	1 5/16, 1, 1 1/16, 1 1/8, 1 3/16, 1 1/4	1/4 x 1/8
	1 5/16, 1 3/8	5/16 x 5/32
	1 7/16, 1 1/2, 1 9/16, 1 5/8, 1 11/16, 1 3/4	3/8 x 3/16
	1 13/16, 1 7/8, 1 15/16, 2, 2 1/16	1/2 x 1/4
	2 1/8, 2 3/16, 2 1/4	1/2 x 1/4
	2 5/16, 2 3/8, 2 7/16, 2 1/2	5/8 x 3/16*
	2 5/8, 2 11/16, 2 3/4, 2 9/16	5/8 x 1/16*
	2 13/16, 2 7/8	3/4 x 1/16*
	2 15/16	No Key

*Shallow Keyseat — Keystock is supplied with bushing

BUSHINGS H AND QD®

Bushing	Bore Range (in.)	Keyseat (in.)
E	7/8, 15/16 1, 1 1/16, 1 1/8, 1 3/16, 1 1/4 1 5/16, 1 3/8, 1 7/16, 1 1/2, 1 9/16, 1 5/8, 1 11/16, 1 3/4 1 13/16, 1 7/8, 1 15/16, 2, 2 1/16, 2 1/8, 2 3/16, 2 1/4 2 5/16, 2 3/8, 2 7/16, 2 1/2, 2 9/16, 2 5/8 2 11/16, 2 3/4 2 13/16, 2 7/8, 2 15/16, 3, 3 1/16 3 1/8, 3 3/16, 3 1/4 3 5/16, 3 3/8, 3 7/16 3 1/2	3/16 X 3/32 1/4 X 1/8 5/16 X 5/32 3/8 X 3/16 1/2 X 1/4 1/2 X 1/4 5/8 X 5/16 5/8 X 5/16 3/4 X 1/8* 3/4 X 1/8* 7/8 X 1/16* No Key
F	1, 1 1/16, 1 1/8, 1 3/16, 1 1/4 1 5/16, 1 3/8 1 7/16, 1 1/2, 1 9/16, 1 5/8, 1 11/16, 1 3/4 1 13/16, 1 7/8, 1 15/16, 2, 2 1/16 2 1/8, 2 3/16, 2 1/4 2 5/16, 2 3/8, 2 7/16, 2 1/2, 2 5/8, 2 9/16 2 11/16, 2 3/4 2 13/16, 2 7/8, 2 15/16, 3, 3 1/16 3 1/8, 3 3/16, 3 1/4 3 5/16, 3 3/8, 3 7/16, 3 1/2, 3 9/16 3 5/8, 3 11/16, 3 3/4 3 7/8, 3 15/16 4	1/4 X 1/8 5/16 X 5/32 3/8 X 3/16 1/2 X 1/4 1/2 X 1/4 5/8 X 5/16 5/8 X 5/16 3/4 X 3/8 3/4 X 3/8 7/8 X 3/16* 7/8 X 3/16* 1 X 1/8* No Key
J	1 7/16, 1 1/2, 1 9/16, 1 5/8, 1 11/16, 1 3/4 1 7/8, 1 15/16, 2, 2 1/16 2 1/8, 2 3/16, 2 1/4 2 5/16, 2 3/8, 2 7/16, 2 1/2, 2 9/16, 2 5/8 2 11/16, 2 3/4, 2 13/16 2 7/8, 2 15/16, 3, 3 1/16 3 1/8, 3 3/16, 3 1/4 3 5/16, 3 3/8, 3 7/16, 3 1/2, 3 11/16 3 5/8, 3 11/16, 3 3/4 3 13/16, 3 7/8, 3 15/16 4, 4 1/8, 4 3/16, 4 1/4, 4 3/8, 4 7/16, 4 1/2	3/8 X 3/16 1/2 X 1/4 1/2 X 1/4 5/8 X 5/16 5/8 X 5/16 3/4 X 3/8 3/4 X 3/8 7/8 X 7/16 7/8 X 7/16* 1 X 3/8* 1 X 1/8*
M	1 15/16, 2, 2 1/16, 2 1/8 2 3/16, 2 1/4, 2 5/16 2 3/8, 2 7/16, 2 1/2, 2 9/16, 2 5/8 2 11/16, 2 3/4, 2 13/16 2 7/8, 2 15/16, 3, 3 1/16 3 1/8, 3 3/16, 3 1/4, 3 5/16 3 3/8, 3 7/16, 3 1/2, 3 9/16 3 5/8, 3 11/16, 3 3/4 3 13/16, 3 7/8, 3 15/16, 4, 4 1/8, 4 3/16, 4 1/4, 4 3/8, 4 7/16, 4 1/2 4 5/8, 4 11/16, 4 3/4, 4 13/16 4 7/8, 4 15/16 5, 5 3/16, 5 1/4, 5 3/8, 5 7/16, 5 1/2	1/2 X 1/4 1/2 X 1/4 5/8 X 5/16 5/8 X 5/16 3/4 X 3/8 3/4 X 3/8 7/8 X 7/16 7/8 X 7/16 1 X 1/2 1 X 1/2 1 1/4 X 5/8 1 1/4 X 3/4* 1 1/4 X 3/4*
N	CALL FOR AVAILABILITY	
P	CALL FOR AVAILABILITY	

*Shallow Keyseat — Keystock is supplied with bushing

Bushing	Bore Range (mm)	Keyseat (mm)
H	10, 11 14, 15, 16 18, 19, 20, 22 24, 25, 28, 30 32, 35, 38	No Key 5 x 5 6 x 6 8 x 7 10 x 8
JA	15, 16 19, 20 24, 25, 28	5 x 5 6 x 6 8 x 7
SH	20, 22 24, 25, 28, 30 32, 35, 38	6 x 6 8 x 7 10 x 8
SDS	24, 25, 28, 30 32, 35, 38 40, 42	8 x 7 10 x 8 12 x 8
SD	24, 25, 28, 30 32, 35, 38 40, 42	8 x 7 10 x 8 12 x 8
SK	14 24, 25, 28, 30 32, 35, 38 40, 42 45, 48, 50 55 60	5 x 5 8 x 7 10 x 8 12 x 8 14 x 9 16 x 10 18 x 11
SF	28, 30 32, 35, 38 40, 42 45, 48, 50 55 60, 65	8 x 7 10 x 8 12 x 8 14 x 9 16 x 10 18 x 11
E	35, 38 40, 42 45, 48, 50 55 60, 65 70, 75 80	10 x 8 12 x 8 14 x 9 16 x 10 18 x 11 20 x 12 22 x 14
F	42 45, 48, 50 55 60, 65 70, 75 80, 85 90	12 x 8 14 x 9 16 x 10 18 x 11 20 x 12 22 x 14 25 x 14
J	50 55 60, 65 70, 75 80, 85 90, 95 100	14 x 9 16 x 10 18 x 11 20 x 12 22 x 14 25 x 14 28 x 16
M	80 90 100 120	22 x 14 25 x 14 28 x 16 32 x 18

BUSHINGS TAPER-LOCK®

Bush No.	Bore Range (in.)	Keyseat (in.)
1008	1/2, 9/16	1/8 X 1/16
	5/8, 11/16, 3/4, 13/16, 7/8	3/16 X 3/32
	15/16, 1	1/4 X 1/16
1108	1/2, 9/16	1/8 X 1/16
	5/8, 11/16, 3/4, 13/16, 7/8	3/16 X 3/32
	15/16, 1	1/4 X 1/8
	1 1/16, 1 1/8	1/4 X 1/16
1210	1/2, 9/16	1/8 X 1/16
1215	5/8, 11/16, 3/4, 13/16, 7/8	3/16 X 3/32
	15/16, 1, 1 1/16, 1 1/8, 1 3/16, 1 1/4	1/4 X 1/8
1310	1/2, 9/16	1/8 X 1/16
	5/8, 11/16, 3/4, 13/16, 7/8	3/16 X 3/32
	15/16, 1, 1 1/16, 1 1/8, 1 3/16, 1 1/4	1/4 X 1/8
	1 5/16, 1 3/8	5/16 X 5/32
1610	1/2, 9/16	1/8 X 1/16
1615	5/8, 11/16, 3/4, 13/16, 7/8	3/16 X 3/32
	15/16, 1, 1 1/16, 1 1/8, 1 3/16, 1 1/4	1/4 X 1/8
	1 5/16, 1 3/8	5/16 X 5/32
	1 7/16, 1 1/2	3/8 X 3/16
	1 9/16, 1 5/8	3/8 X 1/8
2012	1/2, 9/16	1/8 X 1/16
	5/8, 11/16, 3/4, 13/16, 7/8	3/16 X 3/32
	15/16, 1, 1 1/16, 1 1/8, 1 3/16, 1 1/4	1/4 X 1/8
	1 5/16, 1 3/8	5/16 X 5/32
	1 7/16, 1 1/2, 1 9/16, 1 5/8, 1 11/16, 1 3/4	3/8 X 3/16
	1 13/16, 1 7/8	1/2 X 1/4
	1 15/16, 2	1/2 X 3/16
2517	1/2, 9/16	1/8 X 1/16
	5/8, 11/16, 3/4, 13/16, 7/8	3/16 X 3/32
	15/16, 1 1/16, 1 1/8, 1 3/16, 1 1/4	1/4 X 1/8
	1 5/16, 1 3/8	5/16 X 5/32
	1 7/16, 1 1/2, 1 9/16, 1 5/8, 1 11/16, 1 3/4	3/8 X 3/16
	1 13/16, 1 7/8, 1 15/16, 2, 2 1/16, 2 1/8, 2 3/16, 2 1/4	1/2 X 1/4
	2 5/16, 2 3/8, 2 7/16, 2 1/2	5/8 X 3/16
2525	3/4, 13/16	3/16 X 3/32
	7/8, 15/16, 1, 1 1/8, 1 3/16, 1 1/4	1/4 X 1/8
	1 15/16, 1 3/8	5/16 X 5/32
	1 7/16, 1 1/2, 1 9/16, 1 5/8, 1 11/16, 1 3/4	3/8 X 3/16
	1 13/16, 1 7/8, 1 15/16, 2, 2 1/8, 2 3/16, 2 1/4	1/2 X 1/4
	2 5/16, 2 3/8, 2 7/16, 2 1/2	5/8 X 3/16
3020	15/16, 1, 1 1/8, 1 3/16, 1 1/4	1/4 X 1/8
	1 5/16, 1 5/8	5/16 X 5/32
	1 7/16, 1 1/2, 1 9/16, 1 5/8, 1 11/16, 1 3/4	3/8 X 3/16
	1 13/16, 1 7/8, 1 15/16, 2, 2 1/16, 2 1/8, 2 3/16, 2 1/4	1/2 X 1/4
	2 5/16, 2 3/8, 2 7/16, 2 1/2, 2 5/8, 2 11/16, 2 3/4	5/8 X 5/16
	2 7/8, 2 15/16, 3	3/4 X 1/4

Bush No.	Bore Range (in.)	Keyseat (in.)
3030	15/16, 1, 1 1/8, 1 3/16, 1 1/4	1/4 X 1/8
	1 5/16, 1 5/8	5/16 X 5/32
	1 7/16, 1 1/2, 1 9/16, 1 5/8, 1 11/16, 1 3/4	3/8 X 3/16
	1 13/16, 1 7/8, 1 15/16, 2, 2 1/16, 2 1/8, 2 3/16, 2 1/4	1/2 X 1/4
	2 5/16, 2 3/8, 2 7/16, 2 1/2, 2 5/8, 2 11/16, 2 3/4	5/8 X 5/16
	2 7/8, 2 15/16, 3	3/4 X 1/4

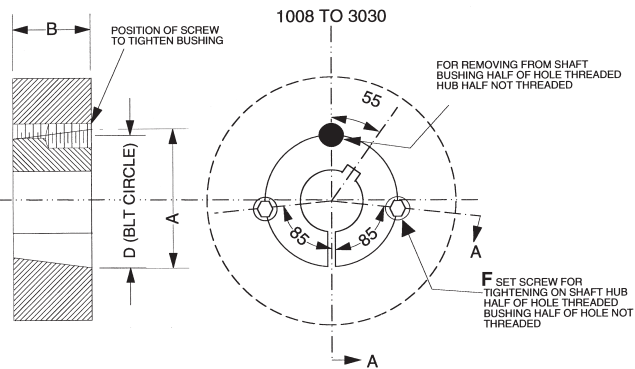

TB	A	B	D	F
1008	1.38	7/8	1 21/64	1/4
1108	1.511	7/8	1 29/64	1/4
1210	1 7/8	1	1 3/4	3/8
1215	1 7/8	1 1/2	1 3/4	3/8
1610	2 1/4	1	2 1/8	3/8
1615	2 1/4	1 1/2	2 1/8	3/8
2012	2 3/4	1 1/4	2 5/8	7/16
2517	3 3/8	1 3/4	3 1/4	1/2
2525	3 3/8	2 1/2	3 1/4	1/2
3020	4 1/4	2	4	5/8
3030	4 1/4	3	5/8	4

BUSHINGS TAPER-LOCK®

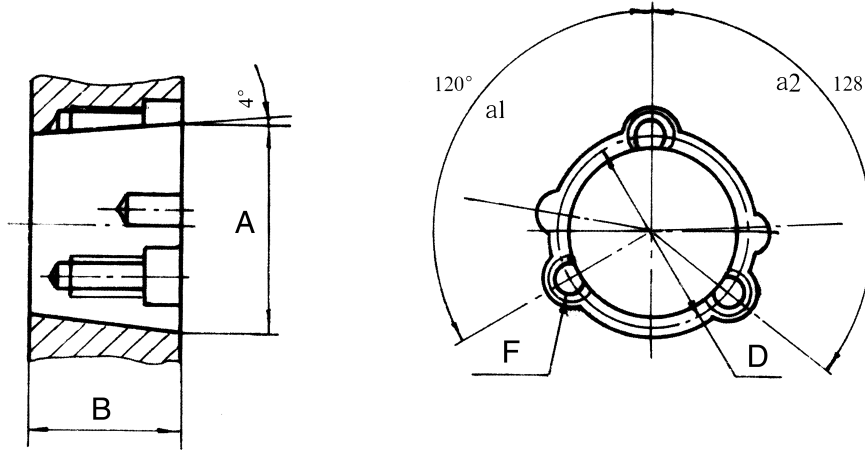

TB	A	B	D	F
3535	5	3½	4.83	½
4040	5¾	4	5.54	⅝
4545	6⅜	4½	6.13	¾
5050	7	5	6.72	⅞

Bush No.	Bore (in.)	Keyseat (in.)
3535	1 ⅜, 1 ¼	¼ x ⅛
	1 ⅝, 1 ⅞	⅝ x ⅝ ₃₂
	1 ⅞ ₁₆ , 1 7 ₁₆ , 1 ½, 1 ⅝, 1 11 ₁₆ , 1 ¾	⅜ x ⅜ ₁₆
	1 7 ₈ , 1 15 ₁₆ , 2, 2 1 ₈ , 2 3 ₁₆ , 2 ¼	½ x ¼
	2 5 ₁₆ , 2 3 ₈ , 2 7 ₁₆ , 2 ½, 2 5 ₈ , 2 11 ₁₆ , 2 ¾	⅝ x ⅝ ₁₆
	2 13 ₁₆ , 2 7 ₈ , 2 15 ₁₆ , 3, 3 1 ₈ , 3 3 ₁₆ , 3 ¼	¾ x ¾ ₈
3 5 ₁₆ , 3 3 ₈ , 3 7 ₁₆ , 3 ½	7 ₈ x ¼	
4040	1 7 ₁₆ , 1 ½, 1 ⅝, 1 11 ₁₆ , 1 ¾	⅜ x ⅜ ₁₆
	1 13 ₁₆ , 1 7 ₈ , 1 15 ₁₆ , 2, 2 1 ₈ , 2 3 ₁₆ , 2 ¼	½ x ¼
	2 5 ₁₆ , 2 3 ₈ , 2 7 ₁₆ , 2 ½, 2 5 ₈ , 2 11 ₁₆ , 2 ¾	⅝ x ⅝ ₁₆
	2 13 ₁₆ , 2 7 ₈ , 2 15 ₁₆ , 3, 3 1 ₈ , 3 3 ₁₆ , 3 ¼	¾ x ¾ ₈
	3 5 ₁₆ , 3 3 ₈ , 3 7 ₁₆ , 3 ½, 3 5 ₈	7 ₈ x 7 ₁₆
	3 11 ₁₆ , 3 ¾	7 ₈ x ¼
	3 13 ₁₆ , 3 7 ₈ , 3 15 ₁₆ , 4	1 x ¼
4545	2 5 ₁₆ , 2 3 ₈ , 2 7 ₁₆ , 2 5 ₈ , 2 ¾	⅝ x ⅝ ₁₆
	2 13 ₁₆ , 2 7 ₈ , 2 15 ₁₆ , 3, 3 1 ₈ , 3 3 ₁₆ , 3 ¼	¾ x ¾ ₈
	3 5 ₁₆ , 3 3 ₈ , 3 7 ₁₆ , 3 ½, 3 5 ₈ , 3 ¾	7 ₈ x 7 ₁₆
	3 13 ₁₆ , 3 7 ₈ , 3 15 ₁₆ , 4, 4 1 ₈ , 4 3 ₁₆ , 4 ¼	1 x ½
	4 5 ₁₆ , 4 3 ₈ , 4 7 ₁₆ , 4 ½	1 x ¼
5050	2 7 ₁₆	⅝ x ⅝ ₁₆
	2 15 ₁₆	¾ x ¾ ₈
	3 3 ₈ , 3 7 ₁₆ , 3 5 ₈	7 ₈ x 7 ₁₆
	3 7 ₈ , 3 15 ₁₆ , 4, 4 ¼, 4 3 ₈ , 4 7 ₁₆ , 4 ½	1 x ½
	4 7 ₈ , 4 15 ₁₆ , 5	1 ¼ x 7 ₁₆

BUSHINGS TAPER-LOCK®

Bushing	Bore Range (mm)	Keyseat (mm)
1008	14, 16	5 x 2.3
	18, 19, 20, 22	6 x 2.8
	24, 25	8 x 2.0
1108	14, 16	5 x 2.3
	18, 19, 20, 22	6 x 2.8
	24, 25	8 x 3.3
	28	8 x 2.0
1210	14, 16	5 x 2.3
	18, 19, 20, 22	6 x 2.8
	24, 25, 28, 30	8 x 3.3
	32	10 x 3.3
	32	10 x 3.3
1215	14, 16	5 x 2.3
	18, 19, 20, 22	6 x 2.8
	24, 25, 28, 30	8 x 3.3
	32	10 x 3.3
1310	14, 16	5 x 2.3
	18, 19, 20, 22	6 x 2.8
	24, 25, 28, 30	8 x 3.3
	32, 25	10 x 3.3
	32, 25	10 x 3.3
1610	14, 16	5 x 2.3
	18, 19, 20, 22	6 x 2.8
	24, 25, 28, 30	8 x 3.3
	32, 35, 38	10 x 3.3
	40, 42	12 x 3.3
1615	14, 16	5 x 2.3
	18, 19, 20, 22	6 x 2.8
	24, 25, 28, 30	8 x 3.3
	32, 35, 38	10 x 3.3
	40, 42	12 x 3.3
2012	18, 19, 20, 22	6 x 2.8
	24, 25, 28, 30	8 x 3.3
	32, 35, 38	10 x 3.3
	40, 42, 45, 48, 50	12 x 3.3
	40, 42, 45, 48, 50	12 x 3.3
2517	20, 22	6 x 2.8
	24, 25, 28, 30	8 x 3.3
	32, 35, 38	10 x 3.3
	40, 42, 45, 48, 50	10 x 3.3
	55, 60	16 x 4.3
3020 and 3030	25, 28, 30	8 x 3.3
	32, 35, 38	10 x 3.3
	40, 42	12 x 3.3
	45, 48, 50	14 x 3.8
	55	16 x 4.3
	60, 65	18 x 4.4
3525	70, 75	20 x 4.9
	80, 85, 90	22 x 5.4
	35, 38	10 x 3.3
	40, 42	12 x 3.3
	45, 48, 50	14 x 3.8
	55	16 x 4.3
	60, 65	18 x 4.4
4545	70, 75	20 x 4.9
	80, 85	22 x 5.4
	90, 95	25 x 5.4
	100, 105, 110	28 x 6.4
	60, 65	18 x 4.4
	70, 75	20 x 4.9
5050	80, 85	22 x 5.4
	90, 95	25 x 5.4
	100, 105, 110	28 x 6.4
	115, 120, 125	32 x 7.4
	60, 65	18 x 4.4
	70, 75	20 x 4.9

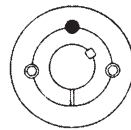

1008 to 3030

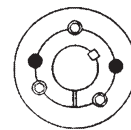

3525 to 5050

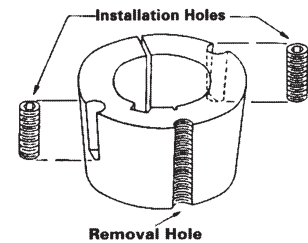

INSTALLATION

1. Properly clean shaft, bore, and taper surface of bushing. Remove or degrease any oil, paint, or dirt.
2. Install the bushing into the pulley hub. Be sure to match the hole pattern, not the threaded holes. Match the half threaded holes with the half straight holes (a complete hole will be threaded on one side only.)
3. Lightly oil the set screws (1008 to 3030) or the cap screws (3525 to 5050) be sure to oil under the cap screw head. Install the screws into the holes that are threaded on the hub side (shown as  in diagram). DO NOT LUBRICATE THE BUSHING TAPER OR BORE. BREAKAGE OF PRODUCT MAY OCCUR.
4. Fit the pulley with the bushing onto the shaft and locate in the proper location. Install key into the keyway of the shaft and bushing.
5. Tighten screws alternately and gradually in accordance with the torques listed on the Recommended Wrench Torque chart.
6. Using a hammer with a block or sleeve (do not hit bushing directly with hammer) tap on large end of the bushing and re-tighten screws per the appropriate Wrench Torque Values.
7. Fill screw heads with grease to eliminate dirt build up.

REMOVAL

1. Remove all screws and lightly oil the point and threads. Oil under cap screws if used.
2. Install screws into the holes that are threaded only on the bushing side (shown as  in diagram).
3. Tighten screws uniformly and alternately until the bushing is loose from in the hub and pulley is free from the shaft. Tap on small end of bushing to assist removal if it does not loosen. Note: One screw is not used for removal.

Recommended Wrench Torque

Bushing #	Lb-In	Nm ²	Set Screw Hex Size
1008, 1108	53	6	3mm
1210, 1215	176	20	5mm
1310	176	20	5mm
1610, 1615	176	20	5mm
2012	273	31	5mm
2517, 2525	422	48	1/4
3020, 3030	790	90	8mm
3535	986	112	3/8
4040	1,670	190	12mm
4545	2,380	270	14mm
5050	3,080	350	14mm

Note: The Metric System does not refer to the keyseat or keyway dimensions as does the English System. Instead dimensions are given for the key itself which is rectangular in shape Not Square as in the English System. Ordering Example: (1008-14MM) or (4545-105MM)

BUSHINGS DOUBLE SPLIT TAPER

DOUBLE SPLIT TAPER BUSHINGS

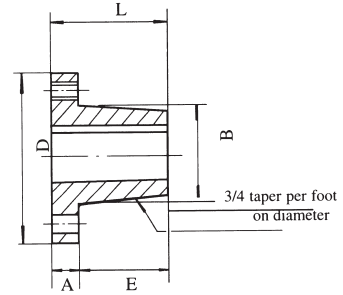
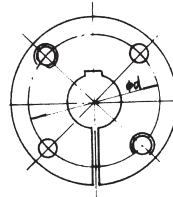
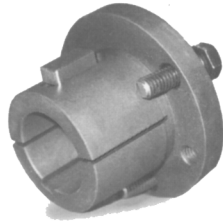
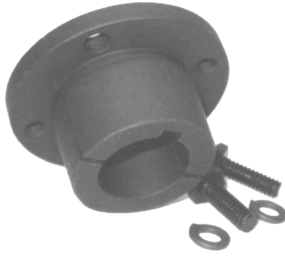

Bushing	Double Split Taper Bushings - Dimensions (inches)					φ d bolt REQUIRED	Cap Screws GRADE 5
	A	B	D	E	L		
G	1/4	1.172	2	3/4	1	1-9/16	2-1/4 X 5/8
H	1/4	1.625	2-1/2	1	1-1/4	2	2-1/4 X 3/4
P1	13/32	1-15/16	3	1-17/32	1-15/15	2-7/16	3-5/16 X 1
P2	13/32	1-15/16	3	2-17/32	2-15/16	2-7/16	3-5/16 X 1
B	1/2	2-5/8	3-11/16	1-7/16	1-15/16	3-1/8	3-5/16 X 1-1/4
Q1	17/32	2-7/8	4-1/8	1-31/32	2-1/2	3-3/8	3-3/8 X 1-1/4
Q2	17/32	2-7/8	4-1/8	2-31/32	3-1/2	3-3/8	3-3/8 X 1-1/4
R1	5/8	4	5-3/8	2-1/4	2-7/8	4-5/8	3-3/8 X 1-3/4
R2	5/8	4	5-3/8	4-1/4	4-7/8	4-5/8	3-3/8 X 1-3/4

Bushing	Bore Range (in.)	Wt.	Key Seat (in.)
G	3/8, 7/16, 3/4	.040	NONE
	1/2, 9/16	.040	1/8 X 1/16
	1/2, 9/16	.040	1/8 X 1/16
	5/8, 11/16, 3/4, 13/16, 7/8	.040	3/16 X 3/32
	15/16, 1	.040	1/4 X 1/8
H	3/8, 7/16, 1/2, 9/16	.090	1/8 X 1/16
	5/8, 11/16, 3/4, 13/16, 7/8	.090	3/16 X 3/32
	15/16, 1, 1 1/16, 1 1/8, 1 3/16, 1 1/4	.090	1/4 X 1/8
	1 5/16, 1 3/8	.090	5/16 X 1/16
	1 3/8(+), 1 7/16, 1 1/2	.090	3/8 X 1/16
P1	1/2, 9/16	.170	1/8 X 1/16
	5/8, 11/16, 3/4, 21/32, 25/32, 13/16, 7/8	.170	3/16 X 3/32
	15/16, 31/32, 1, 1 1/16, 1 1/16, 1 1/8, 1 3/16, 1 1/4	.170	5/16 X 5/32
	11/16, 1 3/4, 1 7/16	.170	13/8 X 3/16
P2	3/4, 13/16, 7/8	.218	3/16 X 3/32
	15/16, 1, 1 11/16, 1 1/8, 1 3/16, 1 1/4	.218	1/4 X 1/8
	1 5/16, 1 3/8	.218	5/16 X 5/32
	1 7/16, 1 1/2, 1 9/16, 1 5/8, 1 11/16, 3/4	.218	3/8 X 3/16
B	1/2, 9/16	.324	1/8 X 1/16
	5/8, 11/16, 3/4, 13/16, 7/8	.324	3/16 X 3/32
	15/16, 1, 1 1/16, 1 1/8, 1 3/16, 1 1/4	.324	1/4 X 1/8
	1 5/16	.324	5/16 X 5/32
	1 3/8, 1 7/16, 1 1/2, 1 5/8, 1 11/16, 1 3/4	.324	3/8 X 3/16
	1 13/16, 1 7/8, 1 15/16, 2, 2 1/16, 2 1/8, 2 3/16, 2 1/4	.324	1/2 X 1/4
	2 5/16, 2 3/8, 2 7/16	.324	5/8 X 5/16
Q1	3/4, 13/16, 7/8	.460	3/16 X 3/32
	15/16, 1, 1 1/16, 1 1/8, 1 3/16, 1 1/4	.460	1/4 X 1/8
	1 5/16, 1 3/8	.460	5/16 X 5/32
	1 7/16, 1 1/2, 1 9/16, 1 5/8, 1 11/16, 1 3/4	.460	3/8 X 3/16
	1 13/16, 1 7/8, 1 15/16, 2, 2 1/16, 2 1/8, 2 3/16, 2 1/4	.460	1/2 X 1/4
	2 5/16, 2 3/8, 2 7/16, 2 1/2, 2 9/16, 2 5/8, 2 11/16	.460	5/8 X 5/16

Bushing	Bore Range (in.)	Wt.	Key Seat (in.)
Q2	1, 1 1/16, 1 1/8, 1 3/16, 1 1/4	5.80	1/4 X 1/8
	15/16, 1	5.80	5/16 X 5/32
	1 3/8, 1 7/16, 1 1/2, 1 9/16, 1 5/8, 11/16, 1 3/4	5.80	3/8 X 3/16
	1 13/16, 1 7/8, 1 5/16, 2, 2 1/16, 2 1/8, 2 3/16, 2 1/4	5.80	1/2 X 1/4
	2 5/16, 2 3/8, 2 7/16, 2 1/2, 2 9/16, 2 5/8	5.80	5/8 X 5/16
R1	11/16,	9.95	3/16 X 3/32
	1 1/8, 1 3/16, 1 1/4, 1 5/16, 1 3/8, 1 7/16	9.95	1/4 X 1/8
	1 1/2, 1 9/16, 1 5/8, 1 11/16, 1 3/4	9.95	3/8 X 3/16
	1 13/16, 1 7/8, 1 15/16, 2 1/16, 2 1/8, 2 3/16, 2 1/4	9.95	1/2 X 1/4
	2 5/16, 2 3/8, 2 7/16, 2 1/2, 2 9/16, 2 5/8, 2 11/16, 2 3/4	9.95	5/8 X 5/16
	2 13/16, 2 7/8, 2 15/16, 3, 3 1/8, 3 3/16, 3 1/4	9.95	3/4 X 3/8
R2	3 3/8, 3 7/16, 3 1/2, 3 5/8, 3 3/4	9.95	7/8 X 7/16
	11/16,	14.38	3/16 X 3/32
	1 3/8, 1 7/16, 1 1/2, 1 9/16, 1 5/8, 1 11/16, 1 3/4	14.38	3/8 X 3/16
	1 13/16, 1 7/8, 1 15/16, 2 1/16, 2 1/8, 2 3/16, 2 1/4 2 5/16	14.38	1/2 X 1/4
	2 3/8, 2 7/16, 2 1/2, 2 9/16, 2 5/8, 2 11/16, 2 3/4	14.38	5/8 X 5/16
	2 13/16, 2 7/8, 2 15/16, 3, 3 1/8, 3 3/16, 3 1/4	14.38	3/4 X 3/8
3 3/8, 3 7/16, 3 1/2, 3 5/8, 3 3/4, 3 3/8			
3 7/16, 3 1/2, 3 5/8	14.38	7/8 X 7/16	

* Shallow Keyseat - Keystock supplied with bushing
 ‡ Oversize Key

Note: A rectangular key is supplied with bushings that have shallow keyseats. This key will fit the standard depth keyseat on the shaft and the shallow keyseat on the bushing.

BUSHINGS DOUBLE SPLIT TAPER

DOUBLE SPLIT TAPER BUSHINGS

Bushing	Bore Range (mm)	Key (mm)	Wt.
G	10,11,12,	No Key	0.4
	14,16,	5 x 2.5	0.4
	18, 19, 20, 22,	6 x 3	0.4
	24, 25	8 x 3.5	0.4
H	10, 11	No Key	0.9
	14, 15, 16,	5 x 5	0.9
	18, 19, 20, 22	6 x 6	0.9
	24, 25, 28, 30	8 x 3.5	1.7
	32,35,38	10 x 8	0.9
P1	14,15,16,	5 X 2.5	1.7
	18, 19, 20, 22	6 x 3	1.7
	24, 25, 28, 30	8 x 7	0.9
	32, 35, 36, 38, 39, 40, 42	10 x 4	1.7
B	15, 16	5 x 2.5	3.2
	18, 19, 20, 22	6 x 3	3.2
	24, 25, 28, 30	8 x 3.5	3.2
	32, 35, 36, 38,	10 x 4	3.2
	40, 42	12 x 4	3.2
	45, 48, 50	14 x 4.5	3.2
	55	16 x 5	3.2
	60	18 x 5.5	3.2
Q1	18, 19, 20, 22	6 x 3	4.60
	24, 25, 28, 30	8 x 3.5	4.60
	32, 35, 36, 38, 40, 42	10 x 4	4.60
	45, 48, 50	14 x 4.5	4.60
	55	16 x 5	4.60
	60, 65	18 x 5.5	4.60
R1	28, 30	8 x 3.5	9.95
	32, 35, 36, 38	10 x 4	9.95
	39, 40	12 x 4	9.95
	42, 45, 48	14 x 4.5	9.95
	50	16 x 5	9.95
	55, 60, 65	18 x 5.5	9.95
	70, 75	20 x 6	9.95
	80, 85	22 x 7	9.95
	90, 95	25 x 7	9.95
	R2	35, 36, 38	10 x 4
39, 40		12 x 4	14.38
42, 45, 48		14 x 4.5	14.38
50		16 x 5	14.38
55, 60, 65		18 x 5.5	14.38
70, 75		20 x 6	14.38
80, 85, 90		22 x 7	14.38

DOUBLE SPLIT TAPER BUSHINGS INSTALLATION INSTRUCTIONS



Installation

1. Properly clean shaft, bore and taper surfaces of bushing. Remove and degrease any excess oil, paint or dirt, this includes the cap screws. Caution: Excessive cap screw torque can cause sheave or bushing breakage. The use of lubricants can cause sheave breakage. **DO NOT USE LUBRICANTS OF ANY TYPE WITH THIS INSTALLATION.**
2. Install the bushing into the hub and match the unthreaded bushing holes with the threaded holes of the hub. Install the cap screws and lock washers through the unthreaded holes and into the threaded holes of the hub. Engage only a few threads by hand – Do not use a wrench.
3. Install key into the keyway path of the shaft and fit assembly onto the shaft and locate in the proper location.
4. Tighten cap screws alternately and gradually. Tighten cap screws to the recommended Wrench Torque Value using a torque wrench

REMOVAL

Remove cap screws and insert into the tapped holes in the bushing. Tighten them alternately and gradually until the bushing disengages from the hub.

Recommended Wrench Torque		
Bushing #	lb-in	lb-ft
G	95	8
H	95	8
P1	192	16
P2	192	16
Q1	348	29
Q2	348	29
R1	348	29
R2	348	29

QD® BUSHING/SHEAVE INSTALLATION

QD bushing sizes JA through J can be assembled in either of the two positions shown below. Size M should be assembled in position one.

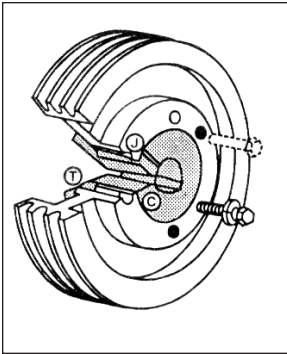

Position 1

Position One is the conventional or standard mounting.

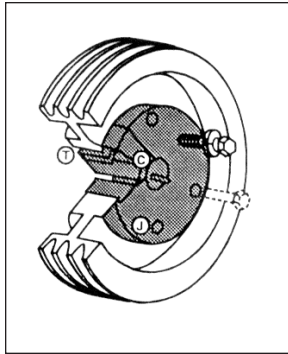

Position 2

Position Two (Reverse Mounting) may be necessary in some cases, such as mounting small sheaves with blind holes (not drilled through).

Bushing Size	Cap Screw Size & Thread	Foot Pounds Wrench Torque*
H	¼ – 28	9
JA	No. 10	3
SH	¼ – 20	6
SDS	¼ – 20	6
SD	¼ – 20	6
SK	⅝ – 18	10
SF	⅜ – 16	20
E	½ – 13	40
F	⅞ – 12	50
J	⅝ – 11	90
M	¾ – 12	150

*For Normal Applications. For Severe (Rock-crusher type) applications these values can be increased by a maximum of 50%.

CAUTION:

Excessive cap-screw torque can cause sheave and/or bushing breakage. The use of lubricants can cause sheave breakage.

DO NOT USE LUBRICANTS IN THIS INSTALLATION!

INSTALLATION

1. Make sure the tapered-cone surface of the bushing and the mating bore of the sheave are free of all foreign substances, such as dirt, excess paint accumulations, metal chips, lubricants, etc.
2. For position one or two (whichever applies), line up the unthreaded holes (C) with the threaded holes (T) and insert cap screws with lock washers engaging only two or three threads. (*a)
3. With key in shaft keyway, slide the loosely-assembled unit onto shaft and position for good belt alignment. (*b, *c) **Use no lubricants or anti-seize compound on threads or tapered surfaces.**
4. Carefully tighten the capscrews alternately and progressively until the tapers are seated (at approximately half the recommended torque).
5. Check alignment and sheave runout (wobble) and correct as necessary.
6. Continue careful alternate and progressive tightening of the cap screws to the recommended torque values shown in the table. **Maximum torque should be achieved on each individual bolt only two times in the consecutive tightening.**

Note: When properly mounted, there will be a gap between the bushing flange and sheave after the screws are tightened.

Caution: Use of Lubricants and/or excessive screw torque can cause breakage.

7. Tighten the set screw, when available, to hold the key securely during operation.
- (*a) When mounting a sheave on M size bushing, position the threaded jack-apart hole (J) as far from the bushing saw as possible to reduce the possibility of bushing breakage.
- (*b) When installing large or heavy parts in *Position One*, it may be easier to mount the key and bushing on the shaft first. Then place the sheave on the bushing and align the holes.
- (*c) **Caution:** When mounting on a vertical shaft, provisions must be made, which will positively prevent the sheave and/or bushing from dropping during installation.

REMOVAL

1. Loosen and remove all mounting cap screws.
2. Insert cap screws in all threaded jack-screw holds (J).
3. Start with the screws furthest from the bushing saw slot and tighten all jack screws alternately and progressively. Keep turning the screws in small equal amounts until the tapered surfaces disengage.

PRODUCT SPECIFICATIONS

SHEAVES

Description	Product Specifications
Gray Cast Iron	Class 25 Gray Cast Iron (<i>ASTM Std.</i>) – <i>Light Duty</i> Class 30 Gray Cast Iron (<i>ASTM Std.</i>) – <i>Heavy Duty</i>
Composition	<p>a. <u>Section Thickness less than 20mm</u></p> <ul style="list-style-type: none"> ✓ Carbon: 3.5% ~ 3.7% ✓ Silicon: 1.9% ~ 2.3% ✓ Manganese: .6% ~ .8% ✓ Phosphorus: .3% Sulfur: .12% <p>b. <u>Section Thickness between 20mm & 40mm</u></p> <ul style="list-style-type: none"> ✓ Carbon: 3.2% ~ 3.4% ✓ Silicon: 1.8% ~ 2.2% ✓ Manganese: .6% ~ .8% ✓ Phosphorus: .3% Sulfur: .12% <p>c. <u>Section Thickness greater than 40mm</u></p> <ul style="list-style-type: none"> ✓ Carbon: 3.1% ~ 3.3% ✓ Silicon: 1.6% ~ 1.9% ✓ Manganese: .6% ~ .8% ✓ Phosphorus: .3% Sulfur: .12%
Microstructure	Slice Pearlitic + Slice Graphite
Brindell Hardness Range	170 ~ 229 (light duty) 187 ~ 241 (heavy duty)
Tensile Strength	Minimum 24,500 psi (light duty) Minimum 29,500 psi (heavy duty)
Coating	Cast iron sheaves are phosphorated before painting. This is to improve the cohesion between the paint film and the base to effectively keep the metal (inside the paint) free from rust. A high quality phosphatic lacquer is used to form a dense and regular gray phosphating film over the iron.
Paint	<ul style="list-style-type: none"> ✓ Type: Amino Baking Enamel ✓ Primary Component: Cyanamid Resin

BUSHINGS

Description	Product Specifications
Nodular Cast Iron	<ul style="list-style-type: none"> ✓ Nodular Graphite Cast Iron ✓ Material Grade QT 500 - 7 International Class (72,387 PSI average range) ✓ Equivalent to U.S. Standard A536/A536-84 (<i>ASTM</i>)
Composition	<p><u>All Nodular Cast Iron Bushings contain:</u></p> <ul style="list-style-type: none"> ✓ Carbon: 3.6% ~ 3.9% ✓ Silicon: 2.2% ~ 2.6% ✓ Manganese: .3% ~ .5% ✓ Phosphorus: .1% Sulfur: .02%
Microstructure	Ferritic + Pearlitic
Brindell Hardness	156 ~ 217
Tensile Strength Range	Minimum 65,000 psi (Equivalent to 500 n/mm ²)
Elongation	7%
Coating/Plating	Cast iron bushings are phosphorated. (<i>Bushings are not painted.</i>)
Bolt Grade	<ul style="list-style-type: none"> ✓ Equivalent to SAE Grade 5 (1,000 n/mm³) ✓ Tensile Strength = 120,000 psi minimum

SYNCHRONOUS TIMING PULLEYS

TYPE 2 F

FOR TL/QD
TYPE BUSHING

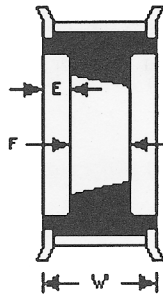

TYPE 3

FOR TL/QD
TYPE BUSHING

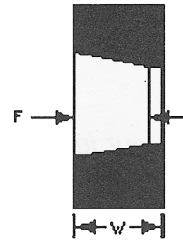

TYPE 3 F

FOR TL/QD
TYPE BUSHING

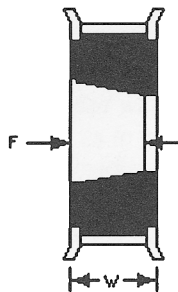

TYPE 4 F

FOR TL/QD
TYPE BUSHING

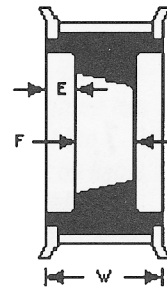

TYPE 5

FOR TL/QD
TYPE BUSHING

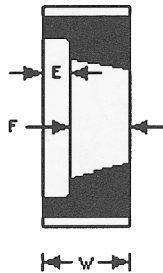

TYPE 5 F

FOR TL/QD
TYPE BUSHING

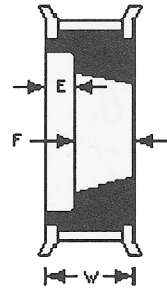

TYPE 6

MINIMUM
PLAIN BORE

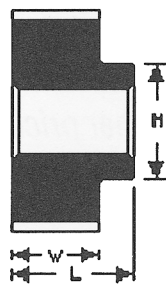

TYPE 6 F

MINIMUM
PLAIN BORE

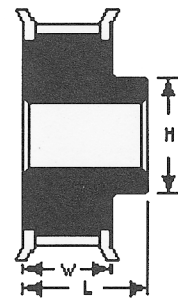

TYPE 7

FOR TL/QD
TYPE BUSHING

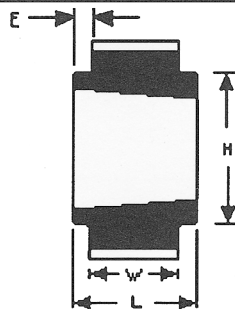

TYPE 8 F

FOR TL
BUSHING

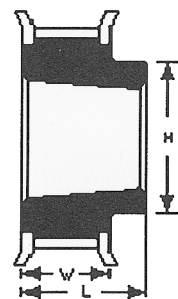

SYNCHRONOUS TIMING PULLEYS

STOCK BORE TIMING PULLEYS

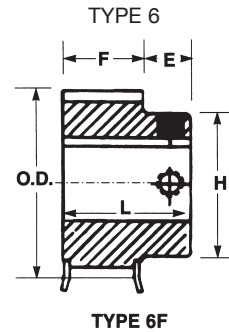

1/5 Inch Pitch (XL) for 1/4" and 3/8" Wide Belts

F Dimension = 9/16"

Pulley No.	Type	No. of Teeth	Nominal Dimensions								Wt. Δ (Approx.) Lbs.
			Pitch Dia.	Pulley OD	Flange OD	E	L	H	Bore		
									MPB	Max.	
P10XL037A	6F	10	.637	.617	.91	7/32	25/32	7/16	3/16	1/4	.03
P10XL037	6F	10	.637	.617	.91	7/32	25/32	7/16	3/16	1/4	.03
P11XL037A	6F	11	.700	.680	.93	7/32	25/32	7/16	3/16	1/4	.03
P11XL037	6F	11	.700	.680	.93	7/32	25/32	7/16	3/16	1/4	.03
P12XL037A	6F	12	.764	.744	.99	7/32	25/32	1/2	3/16	5/16	.06
P12XL037	6F	12	.764	.744	.99	7/32	25/32	1/2	3/16	5/16	.06
P13XL037A	6F	13	.828	.808	1.06	1/4	13/16	9/16	1/4	3/8	.06
P14XL037A	6F	14	.891	.871	1.12	7/32	25/32	9/16	1/4	3/8	.06
P14XL037	6F	14	.891	.871	1.12	7/32	25/32	9/16	1/4	3/8	.06
P15XL037A	6F	15	.955	.935	1.18	7/32	25/32	5/8	1/4	7/16	.09
P15XL037	6F	15	.955	.935	1.18	7/32	25/32	5/8	1/4	7/16	.09
P16XL037A	6F	16	1.019	.999	1.25	7/32	25/32	11/16	1/4	1/2	.09
P16XL037	6F	16	1.019	.999	1.25	7/32	25/32	11/16	1/4	1/2	.09
P17XL037A	6F	17	1.082	1.062	1.31	7/32	25/32	3/4	1/4	1/2	.13
P18XL037A	6F	18	1.146	1.126	1.38	7/32	25/32	13/16	1/4	9/16	.13
P18XL037	6F	18	1.146	1.126	1.38	7/32	25/32	13/16	1/4	9/16	.13
P19XL037A	6F	19	1.210	1.19	1.44	1/4	25/32	7/8	1/4	9/16	.15
P20XL037A	6F	20	1.273	1.253	1.50	11/32	7/8	15/16	1/4	11/16	.19
P20XL037	6F	20	1.273	1.253	1.50	11/32	7/8	15/16	1/4	11/16	.19
P21XL037A	6F	21	1.337	1.317	1.57	11/32	7/8	15/16	1/4	11/16	.19
P21XL037	6F	21	1.337	1.317	1.57	11/32	7/8	15/16	1/4	11/16	.19
P22XL037A	6F	22	1.401	1.381	1.63	11/32	7/8	1	1/4	3/4	.22
P22XL037	6F	22	1.401	1.381	1.63	11/32	7/8	1	1/4	3/4	.22
P23XL037A	6F	23	1.464	1.444	1.69	5/16	7/8	1-1/16	1/4	13/16	.25
P24XL037A	6F	24	1.528	1.508	1.76	11/32	7/8	1-1/16	1/4	13/16	.25
P24XL037	6F	24	1.528	1.508	1.76	11/32	7/8	1-1/16	1/4	13/16	.25
P25XL037A	6F	25	1.592	1.572	1.81	11/32	7/8	1-1/16	1/4	13/16	.25
P26XL037A	6F	26	1.655	1.635	1.88	11/32	7/8	1-3/16	1/4	15/16	.34
P28XL037A	6F	28	1.783	1.763	2.01	11/32	7/8	1-3/16	1/4	15/16	.34
P30XL037A	6F	30	1.910	1.890	2.14	11/32	7/8	1-3/8	5/16	1-1/16	.41
P32XL037A	6	32	2.037	2.017	-	7/16	1	1-1/2	5/16	1-3/16	.22
P36XL037A	6	36	2.292	2.272	-	7/16	1	1-1/2	5/16	1-3/16	.30
P40XL037A	6	40	2.546	2.526	-	7/16	1	1-1/2	5/16	1-3/16	.31
P42XL037A	6	42	2.674	2.654	-	7/16	1	1-1/2	5/16	1-3/16	.31
P44XL037A	6	44	2.801	2.781	-	7/16	1	1-1/2	5/16	1-3/16	.31
P48XL037A	6	48	3.056	3.036	-	7/16	1	1-1/2	5/16	1-3/16	.38
P60XL037A	6	60	3.820	3.800	-	7/16	1	1-1/2	5/16	1-3/16	.38
P72XL037A	6	72	4.584	4.564	-	7/16	1	1-1/2	3/8	1-3/16	.50

A=Aluminum Construction; others are steel.

All pulleys have two (2) set screws at 90°.

Δ Weights shown are approximate, are based on mid-range bore size, and in some cases may be calculated.

Dimensions shown are for reference purposes only, and are subject to change without notice. Where space requirements are critical, consult IDC-USA® for certified specifications.

SYNCHRONOUS TIMING PULLEYS

STOCK BORE TIMING PULLEYS

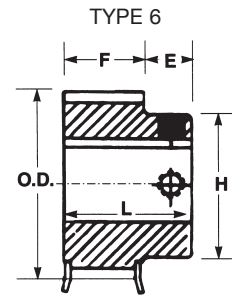

TYPE 6F

3/8 Inch Pitch (L) for 1/2" and 3/4" Wide Belts

Pulley No.	Type	No. of Teeth	Nominal Dimensions							Bore		Wt. Δ (Approx.) Lbs.
			Pitch Dia.	Pulley OD	Flange OD	E	L	H	MPB	Max.		
1/2" (050) F Dimension = 3/4"												
P10L050	6F	10	1.194	1.164	1-7/16	3/4	1-1/8	13/16	3/8	1/2	.20	
P12L050	6F	12	1.432	1.402	1-11/16	3/4	1-1/4	1-1/16	3/8	1/2	.40	
P13L050.3	6F	13	1.552	1.522	1-25/32	3/4	1-1/4	1-1/8	3/8	3/4	.50	
P13L050.5	6F	13	1.552	1.522	1-25/32	3/4	1-1/4	1-1/8	1/2	3/4	.50	
P14L050	6F	14	1.671	1.641	1-15/16	3/4	1-1/4	1-1/8	3/8	3/4	.50	
P15L050.3	6F	15	1.790	1.760	2-1/64	3/4	1-1/4	1-5/16	3/8	3/4	.60	
P15L050.5	6F	15	1.790	1.760	2-1/64	3/4	1-1/4	1-5/16	1/2	3/4	.60	
P15L050.6	6F	15	1.790	1.760	2-1/64	3/4	1-1/4	1-5/16	5/8	3/4	.60	
P15L050.7	6F	15	1.790	1.760	2-1/64	3/4	1-1/4	1-5/16	3/4	3/4	.60	
P16L050	6F	16	1.910	1.880	2-3/16	3/4	1-1/4	1-7/16	1/2	1	.80	
P17L050	6F	17	2.029	1.999	2-9/32	3/4	1-3/8	1-1/2	1/2	1-1/8	.90	
P18L050	6F	18	2.149	2.119	2-3/8	3/4	1-3/8	1-9/16	1/2	1-3/16	.75	
P19L050	6F	19	2.268	2.238	2-1/2	3/4	1-3/8	1-5/8	1/2	1-3/16	1.10	
P20L050	6F	20	2.387	2.357	2-5/8	3/4	1-3/8	1-11/16	1/2	1-1/4	.94	
P21L050	6F	21	2.507	2.477	2-47/64	3/4	1-7/16	1-7/8	1/2	1-5/16	1.30	
P22L050	6F	22	2.626	2.596	2-7/8	3/4	1-1/2	2	1/2	1-1/2	1.10	
P24L050	6F	24	2.865	2.835	3-1/8	3/4	1-1/2	2-1/4	1/2	1-5/8	1.60	
P26L050	6F	26	3.104	3.074	3-3/8	3/4	1-1/2	2-1/4	1/2	1-5/8	2.30	
P28L050	6F	28	3.342	3.312	3-5/8	3/4	1-1/2	2-1/4	1/2	1-5/8	2.50	
P30L050	6F	30	3.581	3.551	3-13/16	3/4	1-1/2	2-1/4	1/2	1-5/8	2.70	
P32L050	6F	32	3.820	3.790	4-1/6	3/4	1-5/8	2-9/16	1/2	1-7/8	3.00	
3/4" (075) F Dimension = 1.0"												
P12L075	6F	12	1.432	1.402	1-1/16	1	1-1/2	1-1/16	3/8	1/2	.50	
P13L075.3	6F	13	1.552	1.522	1-25/32	1	1-1/2	1-1/8	3/8	3/4	.60	
P13L075.5	6F	13	1.552	1.522	1-25/32	1	1-1/2	1-1/8	1/2	3/4	.60	
P14L075	6F	14	1.671	1.641	1-15/16	1	1-1/2	1-7/16	3/8	3/4	.60	
P15L075.5	6F	15	1.790	1.760	2-1/32	1	1-5/8	1-1/2	1/2	3/4	.75	
P15L075.6	6F	15	1.790	1.760	2-1/32	1	1-5/8	1-1/2	5/8	3/4	.75	
P15L075.7	6F	15	1.790	1.760	2-1/32	1	1-5/8	1-1/2	3/4	3/4	.75	
P16L075	6F	16	1.910	1.880	2-3/16	1	1-5/8	1-7/16	1/2	1	.90	
P17L075	6F	17	2.029	1.999	2-9/32	1	1-5/8	1-1/2	1/2	1-1/8	1.00	
P18L075	6F	18	2.149	2.119	2-3/8	1	1-5/8	1-9/16	1/2	1-3/16	.90	
P19L075	6F	19	2.268	2.238	2-1/2	1	1-5/8	1-5/8	1/2	1-3/16	1.30	
P20L075	6F	20	2.387	2.357	2-5/8	1	1-5/8	1-11/16	1/2	1-1/4	1.10	
P21L075	6F	21	2.507	2.477	2-47/64	1	1-11/16	1-7/8	5/8	1-5/16	1.50	
P22L075	6F	22	2.626	2.596	2-7/8	1	1-3/4	2	5/8	1-1/2	1.60	
P24L075	6F	24	2.865	2.835	3-1/8	1	1-3/4	2-1/4	5/8	1-5/8	1.80	
P26L075	6F	26	3.104	3.074	3-3/8	1	1-3/4	2-1/4	5/8	1-5/8	2.10	
P28L075	6F	28	3.342	3.312	3-5/8	1	1-3/4	2-1/4	5/8	1-5/8	2.80	
P30L075	6F	30	3.581	3.551	3-13/16	1	1-3/4	2-1/4	5/8	1-5/8	3.10	
P32L075	6F	32	3.820	3.790	4-1/16	1	1-7/8	2-9/16	5/8	1-7/8	3.40	

P10, P12, P14 and P16 have one (1) set screw. Other sizes have no set screw.

Δ Weights shown are approximate, are based on mid-range bore size, and in some cases may be calculated.

Dimensions shown are for reference purposes only, and are subject to change without notice. Where space requirements are critical, consult IDC-USA® for certified specifications.

SYNCHRONOUS TIMING PULLEYS

STOCK BORE TIMING PULLEYS

3/8 Inch Pitch (L) for 1" Wide Belts

Pulley No.	Type	No. of Teeth	Nominal Dimensions								Wt. Δ (Approx.) Lbs.
			Pitch Dia.	Pulley OD	Flange OD	E	L	H	Bore		
									MPB	Max.	
1.0" (100) F Dimension = 1-1/4"											
P13L100.3	6F	13	1.552	1.522	1-25/32	1-1/4	1-3/4	1-1/8	3/8	3/4	.70
P13L100.5	6F	13	1.552	1.522	1-25/32	1-1/4	1-3/4	1-1/8	1/2	3/4	.70
P14L100	6F	14	1.671	1.641	1-15/16	1-1/4	1-3/4	1-7/16	3/8	3/4	.80
P15L100.5	6F	15	1.790	1.760	2-1/32	1-1/4	1-3/4	1-1/2	1/2	3/4	.85
P15L100.6	6F	15	1.790	1.760	2-1/32	1-1/4	1-3/4	1-1/2	5/8	3/4	.85
P15L100.7	6F	15	1.790	1.760	2-1/32	1-1/4	1-3/4	1-1/2	3/4	3/4	.85
P16L100	6F	16	1.910	1.880	2-3/16	1-1/4	1-7/8	1-7/16	1/2	1	1.10
P17L100	6F	17	2.029	1.999	2-9/32	1-1/4	1-7/8	1-1/2	1/2	1-1/8	1.20
P18L100	6F	18	2.149	2.119	2-3/8	1-1/4	1-7/8	1-9/16	1/2	1-3/16	1.10
P19L100	6F	19	2.268	2.238	2-1/2	1-1/4	1-7/8	1-5/8	1/2	1-3/16	1.60
P20L100	6F	20	2.387	2.357	2-5/8	1-1/4	1-7/8	1-11/16	1/2	1-1/4	1.80
P21L100	6F	21	2.507	2.477	2-47/64	1-1/4	1-15/16	1-7/8	5/8	1-5/16	1.80
P22L100	6F	22	2.626	2.596	2-7/8	1-1/4	2	2	5/8	1-1/2	2.00
P24L100	6F	24	2.865	2.835	3-1/8	1-1/4	2	2-1/4	5/8	1-5/8	2.50
P26L100	6F	26	3.104	3.074	3-3/8	1-1/4	2-1/8	2-9/16	5/8	1-7/8	3.30
P28L100	6F	28	3.342	3.312	3-5/8	1-1/4	2-1/4	2-13/16	5/8	2	3.60
P30L100	6F	30	3.581	3.551	3-13/16	1-1/4	2-1/4	2-15/16	5/8	2-1/8	4.00
P32L100	6F	32	3.820	3.790	4-1/16	1-1/4	2-1/4	3-1/8	5/8	2-7/8	4.40

P14 and P16 have one (1) set screw. Other sizes have no set screw.

Δ Weights shown are approximate, are based on mid-range bore size, and in some cases may be calculated.

Dimensions shown are for reference purposes only, and are subject to change without notice. Where space requirements are critical, consult IDC-USA® for certified specifications.

SYNCHRONOUS TIMING PULLEYS

STOCK BORE TIMING PULLEYS

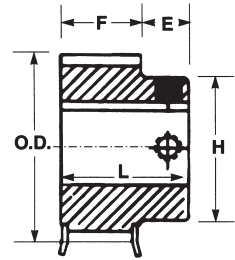

TYPE 6F

1/2 Inch Pitch (H) for 1", 1-1/2", 2.0" and 3.0" Wide Belts

Pulley No.	Type	No. of Teeth	Nominal Dimensions							Bore		Wt. Δ (Approx.) Lbs.
			Pitch Dia.	Pulley OD	Flange OD	E	L	H	MPB	Max.		
1" (100) F Dimension = 1-3/16"												
P14H100	6F	14	2.228	2.174	2-15/32	1-5/16	2-1/2	1-1/2	5/8	1	1.4	
P16H100	6F	16	2.546	2.492	2-25/32	1-5/16	2-1/16	2	5/8	1-1/4	2.0	
P18H100	6F	18	2.865	2.811	3-1/8	1-5/16	2-1/16	2-1/4	5/8	1-1/2	2.8	
P19H100	6F	19	3.024	2.970	3-1/4	1-5/16	2-1/8	2-3/8	5/8	1-9/16	3.0	
P20H100	6F	20	3.183	3.129	3-27/64	1-5/16	2-3/16	2-1/2	5/8	1-5/8	3.4	
P21H100	6F	21	3.342	3.288	3-37/64	1-5/16	2-5/16	2-5/8	3/4	1-11/16	3.8	
P22H100	6F	22	3.501	3.447	3-3/4	1-5/16	2-5/16	2-7/8	3/4	1-7/8	4.3	
P24H100	6F	24	3.820	3.766	4-1/16	1-5/16	2-5/16	3-1/8	3/4	2-1/8	5.3	
P26H100	6F	26	4.138	4.084	4-3/8	1-5/16	2-7/16	3-1/2	3/4	2-1/2	6.7	
P28H100	6F	28	4.456	4.402	4-11/16	1-5/16	2-7/16	3-5/8	3/4	2-5/8	8.0	
1-1/2" (150) F Dimension = 1-13/16"												
P14H150	6F	14	2.228	2.174	2-15/32	1-13/16	2-7/16	1-1/2	3/8	1	1.8	
P16H150	6F	16	2.546	2.492	2-25/32	1-13/16	2-9/16	2	3/4	1-1/4	2.5	
P18H150	6F	18	2.865	2.811	3-1/8	1-13/16	2-9/16	2-1/4	3/4	1-1/2	3.3	
P19H150	6F	19	3.024	2.970	3-1/4	1-13/16	2-5/8	2-3/8	3/4	1-9/16	3.7	
P20H150	6F	20	3.183	3.129	3-27/64	1-13/16	2-11/16	2-1/2	3/4	1-5/8	4.3	
P21H150	6F	21	3.342	3.288	3-37/64	1-13/16	2-3/4	2-5/8	3/4	1-11/16	4.8	
P22H150	6F	22	3.501	3.447	3-3/4	1-13/16	2-13/16	2-7/8	3/4	1-7/8	5.4	
P24H150	6F	24	3.820	3.766	4-1/16	1-13/16	2-13/16	3-1/8	3/4	2-1/8	6.5	
P26H150	6F	26	4.138	4.084	4-3/8	1-13/16	2-13/16	3-1/2	3/4	2-1/2	8.4	
P28H150	6F	28	4.456	4.402	4-11/16	1-13/16	2-15/16	3-5/8	3/4	2-5/8	9.3	
2" (200) F Dimension = 2-11/32"												
P14H200	6F	14	2.228	2.174	2-15/32	2-11/32	2-31/32	1-1/2	3/4	1	2.2	
P16H200	6F	16	2.546	2.492	2-25/32	2-11/32	3-3/32	2	3/4	1-1/4	3.1	
P18H200	6F	18	2.865	2.811	3-1/8	2-11/32	3-3/32	2-1/4	3/4	1-1/2	3.9	
P19H200	6F	19	3.024	2.970	3-1/4	2-11/32	3-5/32	2-3/8	3/4	1-9/16	4.6	
P20H200	6F	20	3.183	3.129	3-27/64	2-11/32	3-7/32	2-1/2	3/4	1-5/8	4.9	
P21H200	6F	21	3.342	3.288	3-37/64	2-11/32	3-9/32	2-5/8	1	1-11/16	5.6	
P22H200	6F	22	3.501	3.447	3-3/4	2-11/32	3-11/32	2-7/8	1	1-7/8	6.3	
P24H200	6F	24	3.820	3.766	4-1/16	2-11/32	3-11/32	3-1/8	1	2-1/8	7.5	
P26H200	6F	26	4.138	4.084	4-3/8	2-11/32	3-15/32	3-1/2	1	2-1/2	9.5	
P28H200	6F	28	4.456	4.402	4-11/16	2-11/32	3-15/32	3-5/8	1	2-5/8	11.0	
3" (300) F Dimension = 3-3/8"												
P16H300	6F	16	2.546	2.492	2-25/32	3-3/8	4-1/8	2	3/4	1-1/4	4.1	
P18H300	6F	18	2.865	2.811	3-1/8	3-3/8	4-1/8	2-1/4	3/4	1-3/8	5.4	
P19H300	6F	19	3.024	2.970	3-1/4	3-3/8	4-1/4	2-3/8	3/4	1-9/16	6.2	
P20H300	6F	20	3.183	3.129	3-27/64	3-3/8	4-1/4	2-1/2	3/4	1-7/8	7.0	
P21H300	6F	21	3.342	3.288	3-37/64	3-3/8	4-5/16	2-5/8	1	1-11/16	7.5	
P22H300	6F	22	3.501	3.447	3-3/4	3-3/8	4-3/8	2-7/8	1-1/8	1-7/8	8.7	
P24H300	6F	24	3.820	3.766	4-1/16	3-3/8	4-3/8	3-1/8	1-1/8	2-1/8	10.0	
P26H300	6F	26	4.138	4.084	4-3/8	3-3/8	4-1/2	3-1/2	1-1/8	2-1/2	12.3	
P28H300	6F	28	4.456	4.402	4-11/16	3-3/8	4-1/2	3-5/8	1-1/8	2-5/8	15.0	

Δ Weights shown are approximate, are based on mid-range bore size, and in some cases may be calculated.

Pulleys are individually boxed. Bulk pack available on special order.

Dimensions shown are for reference purposes only, and are subject to change without notice. Where space requirements are critical, consult IDC-USA® for certified specifications.

SYNCHRONOUS TIMING PULLEYS

STOCK BORE TIMING PULLEYS

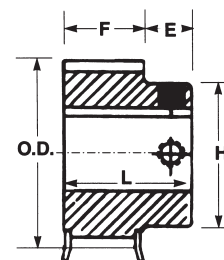

TYPE 6F

5MM Pitch (HT) for 15MM and 25MM Wide Belts

Pulley No.	Type	No. of Teeth	Nominal Dimensions							Bore		Wt. Δ (Approx.) Lbs.
			Pitch Dia.	Pulley OP	Flange OD	E	L	H	MPB	Max.		
15MM			F Dimension = 0.84"									
P32-5M-15	6F	32	2.005	1.960	2.16	.50	1.34	1.55	.5	.88	.84	
P34-5M-15	6F	34	2.130	2.085	2.29	.50	1.34	1.68	.5	1.00	.93	
P36-5M-15	6F	36	2.256	2.211	2.41	.50	1.34	1.80	.5	1.12	1.03	
25MM			F Dimension = 1.23"									
P32-5M-25	6F	32	2.005	1.960	2.16	.50	1.73	1.55	.50	.88	1.19	
P34-5M-25	6F	34	2.130	2.085	2.29	.50	1.73	1.68	.50	1.00	1.38	
P36-5M-25	6F	36	2.256	2.211	2.41	.50	1.73	1.80	.50	1.12	1.56	

8MM Pitch (HT) for 20MM and 30MM Wide Belts

Pulley No.	Type	No. of Teeth	Nominal Dimensions							Bore		Wt. Δ (Approx.) Lbs.
			Pitch Dia.	Pulley OD	Flange OD	E	L	H	MPB	Max.		
20MM			F Dimension = 1-5/32"									
P22-8M-20	6F	22	2.206	2.152	2.559	5/8	1-3/4	1-5/8	1/2	1-3/16	1.1	
30MM			F Dimension = 1-17/32"									
P22-8M-30	6F	22	2.206	2.152	2.559	5/8	2-1/8	1-5/8	1/2	1-3/16	1.4	
P24-8M-30	6F	24	2.406	2.352	2.756	5/8	2-1/8	1-13/16	1/2	1-1/4	1.8	
P26-8M-30	6F	26	2.607	2.553	2.953	5/8	2-1/4	2	1/2	1-1/4	2.2	

14MM Pitch (HT) for 85MM and 115MM Wide Belts

Pulley No.	Type	No. of Teeth	Nominal Dimensions							Bore		Wt. Δ (Approx.) Lbs.
			Pitch Dia.	Pulley OP	Flange OD	E	L	H	MPB	Max.		
85MM			F Dimension = 4.0"									
P28-14M-85	D1F	28	4.912	4.808	5.56	1	4	3-11/16	1-1/4	2-11/16	17	
P29-14M-85	D1F	29	5.088	4.983	5.56	1	4	3-11/16	1-1/4	2-11/16	18	
115MM			F Dimension = 5-1/4"									
P28-14M-115	D1F	28	4.912	4.808	5.56	1-1/4	5	3-11/16	1-1/4	2-11/16	21	
P29-14M-115	D1F	29	5.088	4.983	5.56	1-1/4	5	3-11/16	1-1/4	2-11/16	23	

Δ Weights shown are approximate, are based on mid-range bore size, and in some cases may be calculated.

Pulleys are individually boxed. Bulk pack available on special order.

Dimensions shown are for reference purposes only, and are subject to change without notice. Where space requirements are critical, consult IDC-USA® for certified specifications.

SYNCHRONOUS TIMING PULLEYS QD®

QD® TIMING PULLEYS

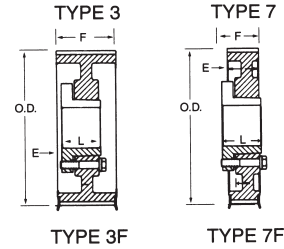

3/8 Inch Pitch (L) for Belts 1/2", 3/4" and 1.0" Wide Belts

Pulley No.	Type	No. of Teeth	Nominal Dimensions						Bushing	Wt. Δ (Approx.) Lbs.
			Pitch Dia.	Pulley OD	Flange OD	E	L	F		
1/2" (050)										
P18L050	3F	18	2.149	2.119	2.38	—	1	3/4	JA	.7
P20L050	3F	20	2.387	2.357	2.62	—	1	3/4	JA	.9
P22L050	3F	22	2.626	2.596	2.88	—	1	3/4	JA	1.1
P24L050	3F	24	2.865	2.835	3.12	—	1-5/16	3/4	SH	1.4
P26L050	3F	26	3.104	3.074	3.38	—	1-5/16	3/4	SH	1.6
P28L050	3F	28	3.342	3.312	3.62	—	1-5/16	3/4	SH	1.9
P30L050	3F	30	3.581	3.551	3.81	—	1-5/16	3/4	SDS	2.2
P32L050	3F	32	3.820	3.790	4.06	—	1-5/16	3/4	SDS	2.5
P36L050	3F	36	4.297	4.267	4.53	—	1-5/16	3/4	SDS	3.0
P40L050	3F	40	4.775	4.745	5.00	—	1-5/16	3/4	SDS	3.6
P44L050	3F	44	5.252	5.222	5.48	—	1-5/16	3/4	SDS	4.3
P48L050	3F	48	5.730	5.700	6.00	—	1-5/16	3/4	SDS	5.1
P60L050	7	60	7.162	7.132	—	1/4	1-13/16	3/4	SD	5.9
P72L050	7	72	8.594	8.564	—	1/4	1-13/16	3/4	SD	7.1
P84L050	7	84	10.027	9.997	—	1/4	1-13/16	3/4	SD	9.0
P96L050	7	96	11.459	11.429	—	1/4	1-13/16	3/4	SD	10.7
P120L050	7	120	14.324	14.294	—	1/4	1-13/16	3/4	SD	13.6
3/4" (075)										
P18L075	3F	18	2.149	2.119	2.38	—	1	1	JA	.8
P20L075	3F	20	2.387	2.357	2.62	—	1	1	JA	1.1
P22L075	3F	22	2.626	2.596	2.88	—	1	1	JA	1.2
P24L075	3F	24	2.865	2.835	3.12	—	1-5/16	1	SH	1.6
P26L075	3F	26	3.104	3.074	3.38	—	1-5/16	1	SH	1.8
P28L075	3F	28	3.342	3.312	3.62	—	1-5/16	1	SH	2.1
P30L075	3F	30	3.581	3.551	3.81	—	1-5/16	1	SDS	2.5
P32L075	3F	32	3.820	3.790	4.06	—	1-5/16	1	SDS	2.8
P36L075	3F	36	4.297	4.267	4.53	1/4	1-5/16	1	SDS	3.3
P40L075	3F	40	4.775	4.745	5.00	1/4	1-5/16	1	SDS	4.0
P44L075	3F	44	5.252	5.222	5.48	1/4	1-5/16	1	SDS	4.8
P48L075	3F	48	5.730	5.700	6.00	1/4	1-5/16	1	SDS	5.6
P60L075	3	60	7.162	7.132	—	—	1-13/16	1	SD	6.6
P72L075	7	72	8.594	8.564	—	1/8	1-13/16	1	SD	7.8
P84L075	7	84	10.027	9.997	—	1/8	1-13/16	1	SD	9.8
P96L075	7	96	11.459	11.429	—	1/8	1-13/16	1	SD	11.7
P120L075	7	120	14.324	14.294	—	1/8	1-13/16	1	SD	14.8
1" (100)										
P18L100	3F	18	2.149	2.119	2.38	—	1	1-1/4	JA	1.0
P20L100	3F	20	2.387	2.357	2.62	—	1	1-1/4	JA	1.3
P22L100	3F	22	2.626	2.596	2.88	—	1	1-1/4	JA	1.3
P24L100	3F	24	2.865	2.835	3.12	—	1-5/16	1-1/4	SH	1.8
P26L100	3F	26	3.104	3.074	3.38	—	1-5/16	1-1/4	SH	2.0
P28L100	3F	28	3.342	3.312	3.62	—	1-5/16	1-1/4	SH	2.4
P30L100	3F	30	3.581	3.551	3.81	—	1-5/16	1-1/4	SDS	2.7
P32L100	3F	32	3.820	3.790	4.06	—	1-5/16	1-1/4	SDS	3.0
P36L100	3F	36	4.297	4.267	4.53	1/4	1-5/16	1-1/4	SDS	3.6
P40L100	3F	40	4.775	4.745	5.00	—	1-5/16	1-1/4	SDS	4.4
P44L100	3F	44	5.252	5.222	5.48	1/2	1-5/16	1-1/4	SDS	5.2
P48L100	3F	48	5.730	5.700	6.00	1/2	1-5/16	1-1/4	SDS	6.1
P60L100	3	60	7.162	7.132	—	—	1-13/16	1-1/4	SD	7.1
P72L100	7	72	8.594	8.564	—	—	1-13/16	1-1/4	SD	8.6
P84L100	7	84	10.027	9.997	—	—	1-13/16	1-1/4	SD	10.7
P96L100	7	96	11.459	11.429	—	—	1-13/16	1-1/4	SD	12.7
P120L100	7	120	14.324	14.294	—	—	1-13/16	1-1/4	SD	16.1

Δ Weights shown are approximate and in some cases may be calculated. Weights do not include bushing.

Pulley Type: F = Flanged

Pulleys are individually boxed. Bulk pack available on special order.

Dimensions shown are for reference purposes only, and are subject to change without notice.

Where space requirements are critical, consult IDC-USA® for certified specifications.

SYNCHRONOUS TIMING PULLEYS QD®

QD® TIMING PULLEYS

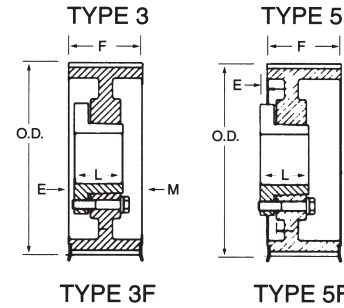

1/2 Inch Pitch (H) for 1.0" and 1-1/2" Wide Belts

TYPE 3F

TYPE 5F

Pulley No.	Type	No. of Teeth	Nominal Dimensions						Bushing	Wt. Δ [Approx.] Lbs.
			Pitch Dia.	Pulley OD	Flange OD	E	L	F		
1.0" (100)										
P14H100	3F	14	2.228	2.174	2.44	—	1	1-5/16	JA	1.1
P16H100	3F	16	2.546	2.492	2.75	—	1	1-5/16	JA	1.2
P18H100	3F	18	2.865	2.811	3.12	—	1-5/16	1-5/16	SH	1.8
P20H100	3F	20	3.183	3.129	3.38	—	1-5/16	1-5/16	SH	2.2
P22H100	3F	22	3.501	3.447	3.75	—	1-5/16	1-5/16	SDS	2.6
P24H100	3F	24	3.820	3.766	4.06	—	1-5/16	1-5/16	SDS	3.0
P26H100	3F	26	4.138	4.084	4.38	—	1-5/16	1-5/16	SDS	3.4
P28H100	3F	28	4.456	4.402	4.69	—	1-5/16	1-5/16	SDS	4.0
P30H100	3F	30	4.775	4.721	5.00	—	1-13/16	1-5/16	SD	5.7
P32H100	3F	32	5.093	5.039	5.31	—	1-15/16	1-5/16	SK	6.6
P36H100	3F	36	5.730	5.676	5.95	—	1-15/16	1-5/16	SK	8.4
P40H100	3F	40	6.366	6.312	6.56	—	1-15/16	1-5/16	SK	10.4
P44H100	3F	44	7.003	6.949	7.25	—	1-15/16	1-5/16	SK	12.6
P48H100	3F	48	7.639	7.585	7.88	—	1-15/16	1-5/16	SK	11.1
P60H100	5	60	9.549	9.495	—	—	2-1/16	1-5/16	SF	15.0
P72H100	5	72	11.459	11.405	—	—	2-1/16	1-5/16	SF	20.8
P84H100	5	84	13.369	13.315	—	—	2-1/16	1-5/16	SF	23.6
P96H100	5	96	15.279	15.225	—	—	2-1/16	1-5/16	SF	26.4
P120H100	5	120	19.099	19.045	—	—	2-1/16	1-5/16	SF	34.4
P156H100	5	156	24.828	24.774	—	—	2-1/16	1-5/16	SF	48.8
1-1/2" (150)										
P14H150	3F	14	2.228	2.174	2.44	—	1	1-13/16	JA	1.3
P16H150	3F	16	2.546	2.492	2.75	—	1	1-13/16	JA	1.4
P18H150	3F	18	2.865	2.811	3.12	—	1-5/16	1-13/16	SH	2.2
P20H150	3F	20	3.183	3.129	3.38	—	1-5/16	1-13/16	SH	2.6
P22H150	3F	22	3.501	3.447	3.75	—	1-13/16	1-13/16	SD	3.5
P24H150	3F	24	3.820	3.766	4.06	—	1-13/16	1-13/16	SD	4.2
P26H150	5F	26	4.138	4.084	4.38	—	1-13/16	1-13/16	SD	4.7
P28H150	5F	28	4.456	4.402	4.69	9/16	1-13/16	1-13/16	SD	5.6
P30H150	5F	30	4.775	4.721	5.00	9/16	1-13/16	1-13/16	SD	6.4
P32H150	5F	32	5.093	5.039	5.31	9/16	1-15/16	1-13/16	SK	7.2
P36H150	5F	36	5.730	5.676	5.95	9/16	1-15/16	1-13/16	SK	9.2
P40H150	5F	40	6.366	6.312	6.56	9/16	1-15/16	1-13/16	SK	11.1
P44H150	5F	44	7.003	6.949	7.25	9/16	1-15/16	1-13/16	SK	13.6
P48H150	5F	48	7.639	7.585	7.88	9/16	1-15/16	1-13/16	SK	12.5
P60H150	5	60	9.549	9.495	—	9/32	2-1/16	1-13/16	SF	16.7
P72H150	5	72	11.459	11.405	—	9/32	2-1/16	1-13/16	SF	22.9
P84H150	5	84	13.369	13.315	—	1/2	2-1/16	1-13/16	SF	25.9
P96H150	5	96	15.279	15.225	—	1/2	2-1/16	1-13/16	SF	29.4
P120H150	5	120	19.099	19.045	—	1/2	2-1/16	1-13/16	SF	38.5
P156H150	5	156	24.828	24.774	—	5/16	2-1/16	1-13/16	SF	54.7

Δ Weights shown are approximate and in some cases may be calculated. Weights do not include bushing.

Pulley Type: F = Flanged

Pulleys are individually boxed. Bulk pack available on special order.

Dimensions shown are for reference purposes only, and are subject to change without notice. Where space requirements are critical, consult IDC-USA® for certified specifications.

SYNCHRONOUS TIMING PULLEYS QD®

QD® TIMING PULLEYS

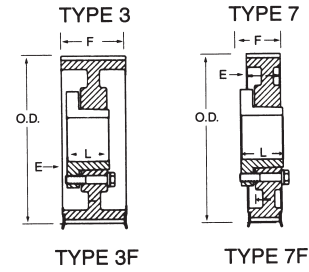

1/2 Inch Pitch (H) for 2.0" and 3.0" Wide Belts

Pulley No.	Type	No. of Teeth	Nominal Dimensions						Bushing	Wt. Δ (Approx.) Lbs.
			Pitch Dia.	Pulley OD	Flange OD	E	L	F		
2.0" (200)										
P14H200	3F	14	2.228	2.174	2.44	—	1	2-11/32	JA	1.7
P16H200	3F	16	2.546	2.492	2.75	—	1	2-11/32	JA	1.7
P18H200	3F	18	2.865	2.811	3.12	—	1-5/16	2-11/32	SH	2.6
P20H200	3F	20	3.183	3.129	3.38	—	1-5/16	2-11/32	SH	3.4
P22H200	3F	22	3.501	3.447	3.75	—	1-5/16	2-11/32	SD	4.1
P24H200	3F	24	3.820	3.766	4.06	—	1-5/16	2-11/32	SD	4.7
P26H200	3F	26	4.138	4.084	4.38	15/16	1-5/16	2-11/32	SD	5.2
P28H200	3F	28	4.456	4.402	4.69	15/16	1-5/16	2-11/32	SD	6.2
P30H200	3F	30	4.775	4.721	5.00	15/16	1-5/16	2-11/32	SD	7.1
P32H200	3F	32	5.093	5.039	5.31	15/16	1-15/16	2-11/32	SK	8.1
P36H200	3F	36	5.730	5.676	5.95	15/16	1-15/16	2-11/32	SK	10.3
P40H200	3F	40	6.366	6.312	6.56	15/16	1-15/16	2-11/32	SK	12.2
P44H200	3F	44	7.003	6.949	7.25	15/16	1-15/16	2-11/32	SK	15.0
P48H200	3F	48	7.639	7.585	7.88	35/64	2-1/16	2-11/32	SF	18.1
P60H200	7	60	9.549	9.495	—	35/64	2-1/16	2-11/32	SF	19.8
P72H200	7	72	11.459	11.405	—	35/64	2-1/16	2-11/32	SF	24.8
P84H200	7	84	13.369	13.315	—	1/8	2-1/16	2-11/32	SF	29.7
P96H200	7	96	15.279	15.225	—	3/8	2-3/4	2-11/32	E	42.3
P120H200	7	120	19.099	19.045	—	3/8	2-3/4	2-11/32	E	53.8
P156H200	7	156	24.828	24.774	—	1/4	2-3/4	2-11/32	E	74.5
3.0" (300)										
P22H300	3F	22	3.501	3.447	3.75	—	1-1/4	3-3/8	SD	5.1
P24H300	3F	24	3.820	3.766	4.06	—	1-1/4	3-3/8	SD	5.8
P26H300	3F	26	4.138	4.084	4.38	1/16	1-1/4	3-3/8	SD	6.2
P28H300	3F	28	4.456	4.402	4.69	1/16	1-1/4	3-3/8	SD	7.5
P30H300	3F	30	4.775	4.721	5.00	7/16	1-1/4	3-3/8	SD	8.7
P32H300	3F	32	5.093	5.039	5.31	3/8	1-7/8	3-3/8	SK	9.6
P36H300	3F	36	5.730	5.676	5.95	3/8	1-7/8	3-3/8	SK	12.4
P40H300	3F	40	6.366	6.312	6.56	3/8	1-7/8	3-3/8	SK	14.3
P44H300	3F	44	7.003	6.949	7.25	3/8	1-7/8	3-3/8	SK	17.6
P48H300	3F	48	7.639	7.585	7.88	3/8	2	3-3/8	SF	21.1
P60H300	3	60	9.549	9.495	—	3/8	2	3-3/8	SF	24.2
P72H300	3	72	11.459	11.405	—	3/8	2	3-3/8	SF	28.5
P84H300	3	84	13.369	13.315	—	3/8	2	3-3/8	SF	34.9
P96H300	3	96	15.279	15.225	—	1/8	2-5/8	3-3/8	E	48.6
P120H300	3	120	19.099	19.045	—	1/8	2-5/8	3-3/8	E	62.2
P156H300	3	156	24.828	24.774	—	1/8	2-5/8	3-3/8	E	86.3

Δ Weights shown are approximate and in some cases may be calculated. Weights do not include bushing.

Pulley Type: F = Flanged

Pulleys are individually boxed. Bulk pack available on special order.

Dimensions shown are for reference purposes only, and are subject to change without notice.

Where space requirements are critical, consult IDC-USA® for certified specifications.

SYNCHRONOUS TIMING PULLEYS TAPER-LOCK®

TAPER-LOCK® TIMING PULLEYS

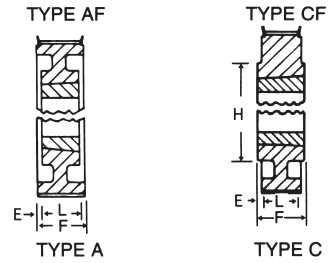

3/8 Inch Pitch (L) for 1/2", 3/4" and 1.0" Wide Belts

Pulley No.	Type	No. of Teeth	Nominal Dimensions							Bushing	Wt. Δ (Approx.) Lbs.
			Pitch Dia.	Pulley OD	Flange OD	E	L	H	F		
1/2" (050)											
TL18L050	CF	18	2.149	2.119	2-3/8	1/8	7/8	1-1/16	3/4	TL1008	.45
TL20L050	CF	20	2.387	2.357	2-5/8	1/8	7/8	1-3/4	3/4	TL1008	.68
TL22L050	CF	22	2.626	2.596	2-7/8	1/8	7/8	2-1/16	3/4	TL1008	.90
TL24L050	CF	24	2.865	2.835	3-1/8	1/4	1	2-1/4	3/4	TL1210	.81
TL26L050	CF	26	3.104	3.074	3-3/8	1/4	1	2-5/8	3/4	TL1210	1.20
TL28L050	CF	28	3.342	3.312	3-5/8	1/4	1	2-3/4	3/4	TL1210	1.40
TL30L050	CF	30	3.581	3.551	3-13/16	1/4	1	2-7/8	3/4	TL1610	1.50
TL32L050	CF	32	3.820	3.790	4-1/16	7/16	1	3-1/16	3/4	TL1610	1.75
TL40L050	CF	40	4.775	4.745	5	7/16	1-1/4	3-5/16	3/4	TL2012	2.40
TL48L050	CF	48	5.730	5.700	6	7/16	1-1/4	3-5/16	3/4	TL2012	4.63
TL60L050	7	60	7.162	7.132	-	1/4	1-1/4	4-3/8	3/4	TL2012	4.90
3/4" (075)											
TL18L075	CF	18	2.149	2.119	2-3/8	1/8	7/8	-	1	TL1008	.50
TL20L075	CF	20	2.387	2.357	2-5/8	1/8	7/8	-	1	TL1008	.81
TL22L075	CF	22	2.626	2.596	2-7/8	1/8	7/8	-	1	TL1008	1.13
TL24L075	CF	24	2.865	2.835	3-1/8	-	1	-	1	TL1210	1.00
TL26L075	CF	26	3.104	3.074	3-3/8	-	1	-	1	TL1210	1.20
TL28L075	CF	28	3.342	3.312	3-5/8	-	1	-	1	TL1610	1.20
TL30L075	CF	30	3.581	3.551	3-13/16	-	1	-	1	TL1610	1.50
TL32L075	CF	32	3.820	3.790	4-1/16	-	1	-	1	TL1610	1.90
TL40L075	CF	40	4.775	4.745	5	3/16	1-1/4	3-1/2	1	TL2012	3.63
TL48L075	CF	48	5.730	5.700	6	3/16	1-1/4	3-15/16	1	TL2012	5.50
TL60L075	CF	60	7.162	7.132	-	1/8	1-1/4	4-3/8	1	TL2012	6.81
1.0" (100)											
TL18L100	CF	18	2.149	2.119	2-3/8	-	7/8	-	1-1/4	TL1008	.70
TL20L100	CF	20	2.387	2.357	2-5/8	-	7/8	-	1-1/4	TL1008	1.00
TL22L100	CF	22	2.626	2.596	2-7/8	-	7/8	-	1-1/4	TL1008	1.30
TL24L100	CF	24	2.865	2.835	3-1/8	-	1	-	1-1/4	TL1210	1.30
TL26L100	CF	26	3.104	3.074	3-3/8	-	1	-	1-1/4	TL1210	1.70
TL28L100	CF	28	3.342	3.312	3-5/8	-	1	-	1-1/4	TL1610	1.70
TL30L100	CF	30	3.581	3.551	3-13/16	-	1	-	1-1/4	TL1610	2.20
TL32L100	CF	32	3.820	3.790	4-1/16	-	1	-	1-1/4	TL1610	2.70
TL40L100	CF	40	4.775	4.745	5	-	1-1/4	-	1-1/4	TL2012	4.13
TL48L100	CF	48	5.730	5.700	6	-	1-1/4	-	1-1/4	TL2012	6.31
TL60L100	C	60	7.162	7.132	-	-	1-1/4	-	1-1/4	TL2012	6.00

Δ Weights shown are approximate and in some cases may be calculated. Weights do not include bushing.

Pulley Type: F = Flanged

Dimensions shown are for reference purposes only, and are subject to change without notice. Where space requirements are critical, consult IDC-USA® for certified specifications.

SYNCHRONOUS TIMING PULLEYS TAPER-LOCK®

TAPER-LOCK® TIMING PULLEYS

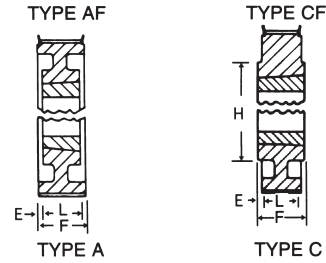

1/2 Inch Pitch (H) for 1.0", 1-1/2", 2" and 3.0" Wide Belts

Pulley No.	Type	No. of Teeth	Nominal Dimensions							Bushing	Wt. Δ (Approx.) Lbs.
			Pitch Dia.	Pulley OD	Flange OD	E	L	H	F		
1.0" (100)											
TL14H100	CF	14	2.228	2.174	2-15/32	7/16	7/8	-	1-5/16	TL1008	.8
TL16H100	CF	16	2.546	2.492	2-25/32	7/16	7/8	-	1-5/16	TL1008	1.3
TL18H100	CF	18	2.865	2.811	3-1/8	5/16	1	-	1-5/16	TL1210	1.2
TL20H100	CF	20	3.183	3.129	3-27/64	5/16	1	-	1-5/16	TL1210	1.7
TL22H100	CF	22	3.501	3.447	3-3/4	5/16	1	-	1-5/16	TL1610	2.0
TL24H100	CF	24	3.820	3.766	4-1/16	1/16	1	-	1-5/16	TL1610	1.8
TL26H100	CF	26	4.138	4.084	4-3/8	1/16	1-1/4	-	1-5/16	TL2012	2.7
TL28H100	CF	28	4.456	4.402	4-11/16	1/16	1-1/4	-	1-5/16	TL2012	3.4
TL30H100	CF	30	4.775	4.721	5	1/16	1-1/4	-	1-5/16	TL2012	3.9
TL32H100	CF	32	5.093	5.039	5-21/64	7/16	1-3/4	4	1-5/16	TL2517	4.1
TL40H100	CF	40	6.366	6.312	6-9/16	7/16	1-3/4	4-7/16	1-5/16	TL2517	8.4
TL48H100	CF	48	7.639	7.585	7-7/8	11/32	1-3/4	4-7/16	1-5/16	TL2517	13.0
1-1/2" (150)											
TL14H150	AF	14	2.228	2.174	2-15/32	15/32	7/8	-	1-13/16	TL1008	1.0
TL16H150	AF	16	2.546	2.492	2-25/32	15/32	7/8	-	1-13/16	TL1008	1.5
TL18H150	CF	18	2.865	2.811	3-1/8	-	1-1/2	-	1-13/16	TL1215	1.8
TL20H150	CF	20	3.183	3.129	3-27/64	-	1-1/2	-	1-13/16	TL1215	2.4
TL22H150	CF	22	3.501	3.447	3-3/4	-	1-1/2	-	1-13/16	TL1615	2.8
TL24H150	CF	24	3.820	3.766	4-1/16	-	1-1/4	-	1-13/16	TL2012	3.1
TL26H150	CF	26	4.138	4.084	4-3/8	-	1-1/4	-	1-13/16	TL2012	3.8
TL28H150	CF	28	4.456	4.402	4-11/16	-	1-1/4	-	1-13/16	TL2012	4.8
TL30H150	CF	30	4.775	4.721	5	-	1-1/4	-	1-13/16	TL2012	5.1
TL32H150	CF	32	5.093	5.039	5-21/64	-	1-3/4	-	1-13/16	TL2517	5.3
TL40H150	CF	40	6.366	6.312	6-9/16	-	1-3/4	-	1-13/16	TL2517	9.2
TL48H150	CF	48	7.639	7.585	7-7/8	-	1-3/4	-	1-13/16	TL2517	16.8
2.0" (200)											
TL16H200	AF	16	2.546	2.492	2-25/32	47/64	7/8	-	2-11/32	TL1008	1.9
TL18H200	AF	18	2.865	2.811	3-1/8	27/64	1-1/2	-	2-11/32	TL1215	2.2
TL20H200	AF	20	3.183	3.129	3-27/64	27/64	1-1/2	-	2-11/32	TL1215	3.1
TL22H200	AF	22	3.501	3.447	3-3/4	27/64	1-1/2	-	2-11/32	TL1615	3.4
TL24H200	AF	24	3.820	3.766	4-1/16	43/64	1-1/4	-	2-11/32	TL2012	3.1
TL26H200	AF	26	4.138	4.084	4-3/8	43/64	1-1/4	-	2-11/32	TL2012	4.3
TL28H200	AF	28	4.456	4.402	4-11/16	43/64	1-1/4	-	2-11/32	TL2012	5.3
TL30H200	AF	30	4.775	4.721	5	43/64	1-1/4	-	2-11/32	TL2012	7.0
TL32H200	CF	32	5.093	5.039	5-21/64	-	1-3/4	-	2-11/32	TL2517	6.8
TL40H200	CF	40	6.366	6.312	6-9/16	-	1-3/4	-	2-11/32	TL2517	13.5
TL48H200	CF	48	7.639	7.585	7-7/8	-	2	-	2-11/32	TL3020	18.9
3.0" (300)											
TL18H300	AF	18	2.865	2.811	3-1/8	15/16	1-1/2	-	3-3/8	TL1215	3.0
TL20H300	AF	20	3.183	3.129	3-27/64	15/16	1-1/2	-	3-3/8	TL1215	4.2
TL22H300	AF	22	3.501	3.447	3-3/4	15/16	1-1/2	-	3-3/8	TL1215	4.6
TL24H300	AF	24	3.820	3.766	4-1/16	1-1/16	1-1/4	-	3-3/8	TL2012	3.8
TL26H300	AF	26	4.138	4.084	4-3/8	1-1/16	1-1/4	-	3-3/8	TL2012	5.4
TL28H300	AF	28	4.456	4.402	4-11/16	1-1/16	1-1/4	-	3-3/8	TL2012	8.0
TL30H300	AF	30	4.775	4.721	5	43/64	1-1/4	-	3-3/8	TL2012	7.0
TL32H300	-	32	5.039	5.039	-	13/16	1-3/4	-	3-3/8	TL2517	7.4
TL40H300	-	40	6.312	6.312	-	13/16	1-3/4	-	3-3/8	TL2517	12.1
TL48H300	-	48	7.585	7.585	-	11/16	2	-	3-3/8	TL3020	16.3

Δ Weights shown are approximate and in some cases may be calculated. Weights do not include bushing.

Pulley Type: F = Flanged

Dimensions shown are for reference purposes only, and are subject to change without notice. Where space requirements are critical, consult IDC-USA® for certified specifications.

SYNCHRONOUS TIMING PULLEYS HTD

5 mm PITCH HTD PULLEYS

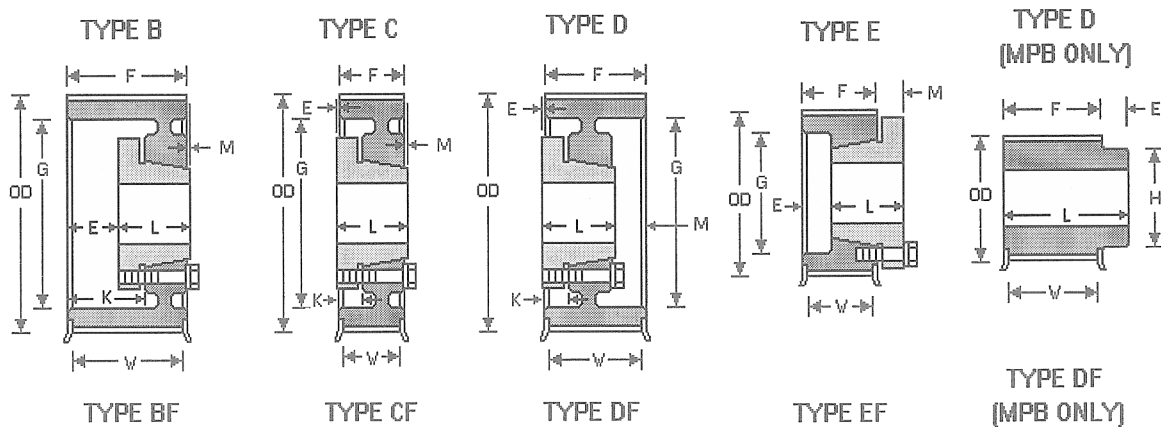

The number following the type letter in the "Type" column indicates the construction (1=Solid, 2=Web, 3=Arms), and the letter 'F' indicates the sprocket has flanges.

15 mm (.591 in.) Wide Belts (5M-15)

Sprocket Code Symbol	Bushing Style	Pitch Diameter (in.)	Outside Diameter (in.)		Type	Dimensions (in.)							Bore Range (in.)		Weight Approx. (lbs)	
			Sprocket	Flange		E	L	M	K	H	F	G	W	min.		max.
P32-5M-15	MPB**	2.005	1.960	2.16	D1F	0.50	1.34			1.55	0.84	0.65	0.5	0.88	0.84	
P34-5M-15	MPB**	2.130	2.085	2.29	D1F	0.50	1.34			1.68	0.84	0.65	0.5	1.00	0.93	
P36-5M-15	MPB**	2.256	2.211	2.41	D1F	0.50	1.34			1.80	0.84	0.65	0.5	1.12	1.03	
P38-5M-15	JA	2.381	2.336	2.54	*E1F	0.28	1.00	0.44			0.84	1.34	0.65	0.5	1.25	0.61
P40-5M-15	JA	2.506	2.461	2.66	*E1F	0.28	1.00	0.44			0.84	1.34	0.65	0.5	1.25	0.72
P44-5M-15	JA	2.757	2.712	2.91	*E1F	0.28	1.00	0.44			0.84	1.34	0.65	0.5	1.25	0.95
P48-5M-15	JA	3.008	2.963	3.16	C1F	0.16	1.00	0.00	0.28		0.84	2.36	0.65	0.5	1.25	0.97
P52-5M-15	JA	3.258	3.213	3.41	C1F	0.16	1.00	0.00	0.28		0.84	2.62	0.65	0.5	1.25	1.17
P56-5M-15	SH	3.509	3.464	3.66	D1F	0.50	1.25	0.09	0.00		0.84		0.65	0.5	1.68	1.37
P60-5M-15	SH	3.760	3.715	3.92	D1F	0.50	1.25	0.09	0.00		0.84		0.65	0.5	1.68	1.68
P64-5M-15	SH	4.010	3.965	4.16	D1F	0.50	1.25	0.09	0.00		0.84		0.5	1.68	1.80	
P68-5M-15	SDS	4.261	4.216	4.41	C1F	0.47	1.31	0.00	0.09		0.84	3.50	0.5	2.00	2.10	
P72-5M-15	SDS	4.511	4.466	4.66	C1F	0.47	1.31	0.00	0.09		0.84	3.75	0.5	2.00	2.43	
P80-5M-15	SDS	5.013	4.968		C1	0.47	1.31	0.00	0.09		0.84	4.25	0.5	2.00	3.15	
P90-5M-15	SDS	5.639	5.594		C1	0.47	1.31	0.00	0.09		0.84	4.88	0.5	2.00	4.17	
P112-5M-15	SDS	7.018	6.973		C1	0.47	1.31	0.00	0.09		0.84	6.05	0.5	2.00	6.75	

25 mm (.984 in.) Wide Belts (5M-25)

P32-5M-25	MPB**	2.005	1.960	2.16	D1F	0.50	1.73			1.55	1.23		1.04	0.5	0.88	1.19
P34-5M-25	MPB**	2.130	2.085	2.29	D1F	0.50	1.73			1.68	1.23		1.04	0.5	1.00	1.38
P36-5M-25	MPB**	2.256	2.211	2.41	D1F	0.50	1.73			1.80	1.23		1.04	0.5	1.12	1.56
P38-5M-25	JA	2.381	2.336	2.54	*E1F	0.67	1.00	0.44			1.23	1.34	1.04	0.5	1.25	0.94
P40-5M-25	JA	2.506	2.461	2.66	*E1F	0.67	1.00	0.44			1.23	1.34	1.04	0.5	1.25	1.06
P44-5M-25	JA	2.757	2.712	2.91	*E1F	0.67	1.00	0.44			1.23	1.34	1.04	0.5	1.25	1.13
P48-5M-25	JA	3.008	2.963	3.16	B1F	0.23	1.00	0.00	0.67		1.23	2.36	1.04	0.5	1.25	1.20
P52-5M-25	JA	3.258	3.213	3.41	B1F	0.23	1.00	0.00	0.67		1.23	2.62	1.04	0.5	1.25	1.75
P56-5M-25	SH	3.509	3.464	3.66	D1F	0.08	1.25	0.06	0.42		1.23	2.86		0.5	1.68	1.75
P60-5M-25	SH	3.760	3.715	3.92	D1F	0.08	1.25	0.06	0.42		1.23	3.12		0.5	1.68	2.13
P64-5M-25	SH	4.010	3.965	4.16	D1F	0.08	1.25	0.06	0.42		1.23	3.37		0.5	1.68	2.50
P68-5M-25	SDS	4.261	4.216	4.41	C1F	0.08	1.31	0.00	0.48		1.23	3.50		0.5	2.00	2.63
P72-5M-25	SDS	4.511	4.466	4.66	C1F	0.08	1.31	0.00	0.48		1.23	3.75		0.5	2.00	3.00
P80-5M-25	SDS	5.013	4.968		C1	0.08	1.31	0.00	0.48		1.23	4.25		0.5	2.00	3.81
P90-5M-25	SDS	5.639	5.594		C1	0.08	1.31	0.00	0.48		1.23	4.88		0.5	2.00	4.69
P112-5M-25	SDS	7.018	6.973		C2	0.08	1.31	0.00	0.48		1.23	6.05		0.5	2.00	6.02

* Reverse mount only.

** MPB furnished less keyseat or setscrew.

Weight shown is for sprocket without bushing.

SYNCHRONOUS TIMING PULLEYS HTD

8 mm PITCH HTD PULLEYS

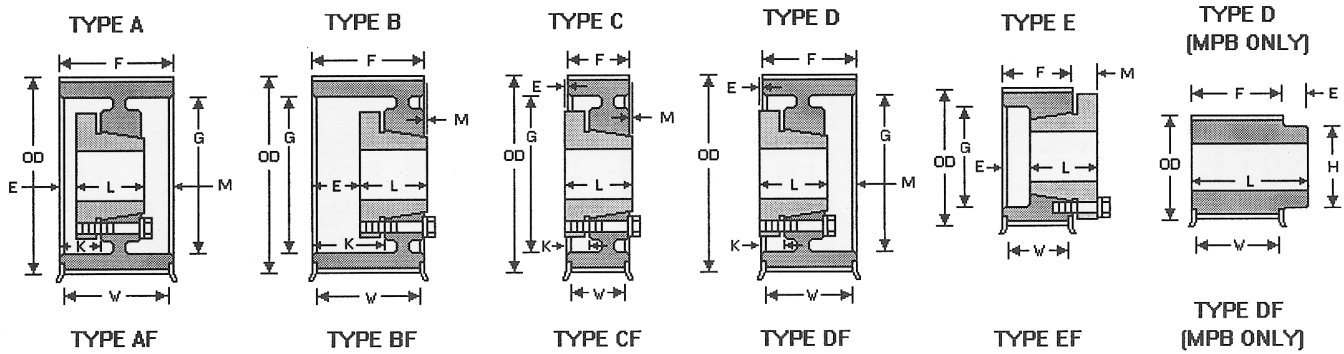

The number following the type letter in the "Type" column indicates the construction (1=Solid, 2=Web, 3=Arms), and the letter 'F' indicates the sprocket has flanges.

20 mm (.79 in.) Wide Belts (8M-20)																
Sprocket Code Symbol	Bushing Style	Pitch Diameter (in.)	Outside Diameter (in.)		Type	Dimensions (in.)							Bore Range (in.)		Weight Approx. (lbs)	
			Sprocket	Flange		E	L	M	K	H	F	G	W	min.		max.
P22-8M-20	MPB**	2.206	2.152	2.559	D1F	5/8	1 3/4	0		1 1/8	1 1/8	7/8	1/2	1 3/16	1.1	
*P24-8M-20	JA	2.406	2.352	2.756	*E1F	9/16	1	7/16		1 1/8	1.34	7/8	1/2	1 1/4	1.0	
*P26-8M-20	JA	2.607	2.553	2.953	*E1F	9/16	1	7/16		1 1/8	1.34	7/8	1/2	1 1/4	1.2	
*P28-8M-20	QT	2.807	2.759	3.150	*E1F	1/4	1 1/4	3/8		1 1/8		7/8	1/2	1 3/8	1.2	
*P30-8M-20	QT	3.008	2.958	3.346	*E1F	1/4	1 1/4	3/8		1 1/8		7/8	1/2	1 3/8	1.4	
P32-8M-20	QT	3.208	3.156	3.543	C1F	1/8	1 1/4	0	1/4	1 1/8	2.56	7/8	1/2	1 3/8	1.5	
P34-8M-20	SH	3.409	3.355	3.819	D1F	3/16	1 1/4	1/16	5/16	1 1/8	2.75	7/8	1/2	1 11/16	1.4	
P36-8M-20	SH	3.609	3.555	3.937	D1F	3/16	1 1/4	1/16	5/16	1 1/8	2.82	7/8	1/2	1 11/16	1.6	
P38-8M-20	SH	3.810	3.756	4.134	D1F	3/16	1 1/4	1/16	5/16	1 1/8	3.00	7/8	1/2	1 11/16	2.1	
P40-8M-20	SH	4.010	3.956	4.331	D1F	3/16	1 1/4	1/16	5/16	1 1/8	3.00	7/8	1/2	1 11/16	2.5	
P44-8M-20	SDS	4.411	4.357	4.764	C1F	3/16	1 5/16	0	3/8	1 1/8	3.50	7/8	1/2	2	2.8	
P48-8M-20	SDS	4.812	4.758	5.157	C1F	3/16	1 5/16	0	3/8	1 1/8	3.80	7/8	1/2	2	3.4	
P56-8M-20	SDS	5.614	5.560	5.945	C1F	3/16	1 5/16	0	3/8	1 1/8	4.60	7/8	1/2	2	4.4	
P64-8M-20	SDS	6.416	6.362	6.772	C1F	3/16	1 5/16	0	3/8	1 1/8	5.40	7/8	1/2	2	6.0	
P72-8M-20	SDS	7.218	7.164	7.598	C2F	3/16	1 5/16	0	3/8	1 1/8	6.20	7/8	1/2	2	5.8	
P80-8M-20	SDS	8.020	7.966	8.386	C2F	3/16	1 5/16	0	3/8	1 1/8	6.90	7/8	1/2	2	7.5	
P90-8M-20	SDS	9.023	8.969		C3	3/16	1 5/16	0	3/8	1 1/8	6.90	7/8	1/2	2	8.0	
30 mm (1.18 in.) Wide Belts (8M-30)																
P22-8M-30	MPB**	2.206	2.152	2.559	D1F	5/8	2 1/8	0		1 5/8	1 1/2	1 1/4	1/2	1 3/16	1.6	
P24-8M-30	MPB**	2.406	2.352	2.756	D1F	5/8	2 1/8	0		1 13/16	1 1/2	1 1/4	1/2	1 1/4	2.0	
P26-8M-30	MPB**	2.607	2.553	2.953	D1F	3/4	2 1/4	0		2	1 1/2	1 1/4	1/2	1 1/4	2.6	
*P28-8M-30	QT	2.807	2.759	3.150	*E1F	5/8	1 1/4	3/8		1 1/2		1 1/4	1/2	1 3/8	1.5	
*P30-8M-30	QT	3.008	2.958	3.346	*E1F	5/8	1 1/4	3/8		1 1/2		1 1/4	1/2	1 3/8	1.9	
P32-8M-30	QT	3.208	3.156	3.543	B1F	1/4	1 1/4	0	5/8	1 1/2	2.56	1 1/4	1/2	1 3/8	1.7	
P34-8M-30	SH	3.409	3.355	3.819	A1F	3/16	1 1/4	1/16	1 1/16	1 1/2	2.75	1 1/4	1/2	1 11/16	1.8	
P36-8M-30	SH	3.609	3.555	3.937	A1F	3/16	1 1/4	1/16	1 1/16	1 1/2	2.82	1 1/4	1/2	1 11/16	2.1	
P38-8M-30	SH	3.810	3.756	4.134	A1F	3/16	1 1/4	1/16	1 1/16	1 1/2	3.00	1 1/4	1/2	1 11/16	2.4	
P40-8M-30	SH	4.010	3.956	4.331	A1F	3/16	1 1/4	1/16	1 1/16	1 1/2	3.00	1 1/4	1/2	1 11/16	2.9	
P44-8M-30	SDS	4.411	4.357	4.764	B1F	3/16	1 5/16	0	3/4	1 1/2	3.50	1 1/4	1/2	2	3.1	
P48-8M-30	SDS	4.812	4.758	5.157	B1F	3/16	1 5/16	0	3/4	1 1/2	3.80	1 1/4	1/2	2	4.0	
P56-8M-30	SDS	5.614	5.560	5.945	B1F	3/16	1 5/16	0	3/4	1 1/2	4.60	1 1/4	1/2	2	5.1	
P64-8M-30	SK	6.416	6.362	6.772	C1F	3/8	1 7/8	0	1/4	1 1/2	5.40	1 1/4	1/2	2 5/8	8.3	
P72-8M-30	SK	7.218	7.164	7.598	C2F	3/8	1 7/8	0	1/4	1 1/2	6.20	1 1/4	1/2	2 5/8	7.7	
P80-8M-30	SK	8.020	7.966	8.386	C2F	3/8	1 7/8	0	1/4	1 1/2	6.90	1 1/4	1/2	2 5/8	9.7	
P90-8M-30	SK	9.023	8.969		C2	3/8	1 7/8	0	1/4	1 1/2	7.90	1 1/4	1/2	2 5/8	13.5	
P112-8M-30	SK	11.229	11.175		C3	3/8	1 7/8	0	1/4	1 1/2	10.00	1 1/4	1/2	2 5/8	15.3	

* Reverse mount only.

** MPB furnished less keyseat or setscrew.

Weight shown is for sprocket without bushing.

SYNCHRONOUS TIMING PULLEYS HTD

8 mm PITCH HTD PULLEYS

50 mm (1.97 in.) Wide Belts (8M-50)																
Sprocket Code Symbol	Bushing Style	Pitch Diameter (in.)	Outside Diameter (in.)		Type	Dimensions (in.)								Bore Range (in.)		Weight Approx. (lbs)
			Sprocket	Flange		E	L	M	K	H	F	G	W	min.	max.	
* P28-8M-50	JA	2.807	2.759	3.150	D1F	0	1	1 ³ / ₁₆	1		2 ³ / ₈	2.09	2 ¹ / ₈	1/2	1 ¹ / ₄	1.6
* P30-8M-50	JA	3.008	2.958	3.346	D1F	0	1	1 ³ / ₁₆	1		2 ³ / ₈	2.25	2 ¹ / ₈	1/2	1 ¹ / ₄	2.0
P32-8M-50	QT	3.208	3.156	3.543	A1F	1/2	1 ¹ / ₄	5/8	7/8		2 ³ / ₈	2.56	2 ¹ / ₈	1/2	1 ³ / ₈	2.2
P34-8M-50	SH	3.409	3.355	3.819	A1F	0	1 ¹ / ₄	1 ¹ / ₈	1/2		2 ³ / ₈	2.75	2 ¹ / ₈	1/2	1 ¹ / ₁₆	2.3
P36-8M-50	SH	3.609	3.555	3.937	A1F	0	1 ¹ / ₄	1 ¹ / ₈	1/2		2 ³ / ₈	2.82	2 ¹ / ₈	1/2	1 ¹ / ₁₆	2.1
P38-8M-50	SH	3.810	3.756	4.134	A1F	0	1 ¹ / ₄	1 ¹ / ₈	1/2		2 ³ / ₈	3.00	2 ¹ / ₈	1/2	1 ¹ / ₁₆	3.3
P40-8M-50	SH	4.010	3.956	4.331	A1F	0	1 ¹ / ₄	1 ¹ / ₈	1/2		2 ³ / ₈	3.00	2 ¹ / ₈	1/2	1 ¹ / ₁₆	4.0
P44-8M-50	SD	4.411	4.357	4.764	A1F	0	1 ³ / ₁₆	9/16	9/16		2 ³ / ₈	3.50	2 ¹ / ₈	1/2	2	5.0
P48-8M-50	SD	4.812	4.758	5.157	A1F	0	1 ³ / ₁₆	9/16	9/16		2 ³ / ₈	3.80	2 ¹ / ₈	1/2	2	5.8
P56-8M-50	SK	5.614	5.560	5.945	D1F	1/16	1 ⁷ / ₈	3/8	9/16		2 ³ / ₈	4.60	2 ¹ / ₈	1/2	2 ³ / ₈	7.4
P64-8M-50	SK	6.416	6.362	6.772	D1F	1/16	1 ⁷ / ₈	3/8	9/16		2 ³ / ₈	5.40	2 ¹ / ₈	1/2	2 ³ / ₈	10.9
P72-8M-50	SK	7.218	7.164	7.598	D1F	1/16	1 ⁷ / ₈	3/8	9/16		2 ³ / ₈	6.20	2 ¹ / ₈	1/2	2 ³ / ₈	13.1
P80-8M-50	SF	8.020	7.966	8.386	D2F	1/16	2	7/16	9/16		2 ³ / ₈	6.90	2 ¹ / ₈	1/2	2 ⁷ / ₈	13.1
P90-8M-50	SF	9.023	8.969		D2	1/16	2	7/16	9/16		2 ³ / ₈	7.90		1/2	2 ⁷ / ₈	19.1
P112-8M-50	SF	11.229	11.175		D3	1/16	2	7/16	9/16		2 ³ / ₈	10.00		1/2	2 ⁷ / ₈	22.0
^P144-8M-50	E	14.437	14.383		D3	1/2	2 ⁵ / ₈	1/4	3/8		2 ³ / ₈	13.20		7/8	3 ¹ / ₂	38.1
^P192-8M-50	E	19.249	19.195		D3	1/2	2 ⁵ / ₈	1/4	3/8		2 ³ / ₈	18.00		7/8	3 ¹ / ₂	52.5
85 mm (3.35 in.) Wide Belts (8M-85)																
P34-8M-85	SH	3.409	3.355	3.819	A1F	1	1 ¹ / ₄	1 ¹ / ₂	1 ¹ / ₂		3 ³ / ₄	2.75	3 ¹ / ₂	1/2	1 ¹ / ₁₆	3.3
P36-8M-85	SH	3.609	3.555	3.937	A1F	1	1 ¹ / ₄	1 ¹ / ₂	1 ¹ / ₂		3 ³ / ₄	2.82	3 ¹ / ₂	1/2	1 ¹ / ₁₆	4.1
P38-8M-85	SH	3.810	3.756	4.134	A1F	1	1 ¹ / ₄	1 ¹ / ₂	1 ¹ / ₂		3 ³ / ₄	3.00	3 ¹ / ₂	1/2	1 ¹ / ₁₆	4.6
P40-8M-85	SD	4.010	4.956	4.331	A1F	1 ¹ / ₁₆	1 ³ / ₁₆	1 ¹ / ₄	1 ¹ / ₄		3 ³ / ₄	3.25	3 ¹ / ₂	1/2	2	4.9
P44-8M-85	SD	4.411	4.357	4.764	A1F	1 ¹ / ₁₆	1 ³ / ₁₆	1 ¹ / ₄	1 ¹ / ₄		3 ³ / ₄	3.50	3 ¹ / ₂	1/2	2	8.4
P48-8M-85	SD	4.812	4.758	5.157	A1F	1 ¹ / ₁₆	1 ³ / ₁₆	1 ¹ / ₄	1 ¹ / ₄		3 ³ / ₄	3.80	3 ¹ / ₂	1/2	2	8.7
P56-8M-85	SK	5.614	5.560	5.945	A1F	5/8	1 ⁷ / ₈	1 ¹ / ₄	1 ¹ / ₄		3 ³ / ₄	4.60	3 ¹ / ₂	1/2	2 ³ / ₈	11.6
P64-8M-85	SK	6.416	6.362	6.772	A1F	5/8	1 ⁷ / ₈	1 ¹ / ₄	1 ¹ / ₄		3 ³ / ₄	5.40	3 ¹ / ₂	1/2	2 ³ / ₈	14.6
P72-8M-85	SF	7.218	7.164	7.598	A1F	5/8	2	1 ¹ / ₈	1 ¹ / ₄		3 ³ / ₄	6.20	3 ¹ / ₂	1/2	2 ⁷ / ₈	18.5
P80-8M-85	SF	8.020	7.966	8.386	A2F	5/8	2	1 ¹ / ₈	1 ¹ / ₄		3 ³ / ₄	6.90	3 ¹ / ₂	1/2	2 ⁷ / ₈	20.4
P90-8M-85	SF	9.023	8.969		A2	5/8	2	1 ¹ / ₈	1 ¹ / ₄		3 ³ / ₄	7.90		1/2	2 ⁷ / ₈	23.7
^P112-8M-85	F	11.229	11.175		A3	5/8	2	1 ¹ / ₈	1 ¹ / ₄		3 ³ / ₄	10.00		1/2	2 ⁷ / ₈	29.6
^P144-8M-85	F	14.437	14.383		A3	3/16	2 ⁵ / ₈	1 ⁵ / ₁₆	1 ¹ / ₁₆		3 ³ / ₄	13.20		7/8	3 ¹ / ₂	50.6
^P192-8M-85	F	19.249	19.195		A3	3/16	2 ⁵ / ₈	1 ⁵ / ₁₆	1 ¹ / ₁₆		3 ³ / ₄	18.00		7/8	3 ¹ / ₂	68.5

^ Check with IDC-USA® for availability. Weight shown is for bushed sprocket without bushing.

*Available MPB or bushing style, check for type.

SYNCHRONOUS TIMING PULLEYS HTD

14 mm PITCH HTD PULLEYS

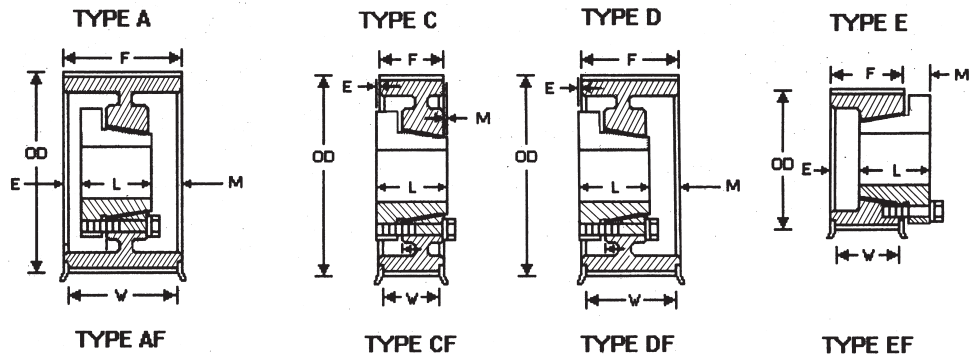

14MM Pitch (HT) for 40MM and 55MM Wide Belts

Pulley No.	Type	No. of Teeth	Nominal Dimensions								Bushing	Wt. Δ (Approx.) Lbs.
			Pitch Dia.	Pulley OD	Flange OD	E	L	F	M	W		
40MM (40) 1.57"												
P28-14M-40	E1F	28	4.912	4.808	5.402	7/8	1-7/8	2-1/8	5/8	1-13/16	SK	5.2
P29-14M-40	E1F	29	5.088	4.983	5.402	7/8	1-7/8	2-1/8	5/8	1-13/16	SK	5.7
P30-14M-40	D1F	30	5.263	5.157	5.763	3/16	1-7/8	2-1/8	7/16	1-13/16	SK	5.6
P32-14M-40	D1F	32	5.614	5.507	6.114	3/16	1-7/8	2-1/8	7/16	1-13/16	SK	7.2
P34-14M-40	D1F	34	5.965	5.858	6.465	3/16	1-7/8	2-1/8	7/16	1-13/16	SK	8.6
P36-14M-40	D1F	36	6.316	6.208	6.816	3/16	2	2-1/8	5/16	1-13/16	SF	9.0
P38-14M-40	D1F	38	6.667	6.559	7.167	3/16	2	2-1/8	5/16	1-13/16	SF	10.6
P40-14M-40	D1F	40	7.018	6.909	7.518	3/16	2	2-1/8	5/16	1-13/16	SF	12.1
P44-14M-40	D1F	44	7.720	7.610	8.395	5/8	2-5/8	2-1/8	1/8	1-13/16	E	14.0
P48-14M-40	D1F	48	8.412	8.311	8.941	5/8	2-5/8	2-1/8	1/8	1-13/16	E	18.4
P52-14M-40	D1F	52	9.123	9.013	9.687	5/8	2-5/8	2-1/8	1/8	1-13/16	E	23.6
P56-14M-40	D1F	56	9.825	9.715	10.355	5/8	2-5/8	2-1/8	1/8	1-13/16	E	27.3
P60-14M-40	D1F	60	10.527	10.417	11.067	5/8	2-5/8	2-1/8	1/8	1-13/16	E	29.0
P64-14M-40	D2F	64	11.229	11.119	11.593	5/8	2-5/8	2-1/8	1/8	1-13/16	E	32.6
P68-14M-40	D2F	68	11.930	11.820	12.500	5/8	2-5/8	2-1/8	1/8	1-13/16	E	36.0
P72-14M-40	D2F	72	12.632	12.522	13.006	5/8	2-5/8	2-1/8	1/8	1-13/16	E	39.8
P80-14M-40	D2F	80	14.036	13.926	14.620	5/8	2-5/8	2-1/8	1/8	1-13/16	E	51.5
P90-14M-40	D3	90	15.790	15.680	-	5/8	2-5/8	2-1/8	1/8	-	E	39.6
P112-14M-40	D3	112	19.650	19.540	-	5/8	2-5/8	2-1/8	1/8	-	E	52.5
P144-14M-40	D3	144	25.264	25.154	-	5/8	2-5/8	2-1/8	1/8	-	E	80.0
55MM (55) 2.17"												
P28-14M-55	E1F	28	4.912	4.808	5.402	1-1/2	1-7/8	2-3/4	5/8	2-7/16	SK	6.5
P29-14M-55	E1F	29	5.088	4.983	5.402	1-1/2	1-7/8	2-3/4	5/8	2-7/16	SK	8.0
P30-14M-55	A1F	30	5.263	5.157	5.763	1/8	1-7/8	2-3/4	3/4	2-7/16	SK	6.7
P32-14M-55	A1F	32	5.614	5.507	6.114	1/8	1-7/8	2-3/4	3/4	2-7/16	SK	8.5
P34-14M-55	A1F	34	5.965	5.858	6.465	1/8	1-7/8	2-3/4	3/4	2-7/16	SK	10.3
P36-14M-55	A1F	36	6.316	6.208	6.816	1/8	2	2-3/4	5/8	2-7/16	SF	10.9
P38-14M-55	A1F	38	6.667	6.559	7.167	1/8	2	2-3/4	5/8	2-7/16	SF	12.2
P40-14M-55	A1F	40	7.018	6.909	7.518	1/8	2	2-3/4	5/8	2-7/16	SF	14.9
P44-14M-55	D1F	44	7.720	7.610	8.395	5/16	2-5/8	2-3/4	7/16	2-7/16	E	16.5
P48-14M-55	D1F	48	8.421	8.311	8.941	5/16	2-5/8	2-3/4	7/16	2-7/16	E	21.8
P52-14M-55	D1F	52	9.123	9.013	9.687	5/16	2-5/8	2-3/4	7/16	2-7/16	E	26.5
P56-14M-55	D1F	56	9.825	9.715	10.355	5/16	2-5/8	2-3/4	7/16	2-7/16	E	31.4
P60-14M-55	D1F	60	10.527	10.417	11.067	5/16	2-5/8	2-3/4	7/16	2-7/16	E	37.0
P64-14M-55	C1F	64	11.229	11.119	11.593	7/8	3-5/8	2-3/4	0	2-7/16	F	50.7
P68-14M-55	D2F	68	11.930	11.820	12.500	7/8	3-5/8	2-3/4	0	2-7/16	F	45.0
P72-14M-55	C2F	72	12.632	12.522	13.006	7/8	3-5/8	2-3/4	0	2-7/16	F	48.2
P80-14M-55	C2F	80	14.036	13.926	14.620	7/8	3-5/8	2-3/4	0	2-7/16	F	56.0
P90-14M-55	C3	90	15.790	15.680	-	7/8	3-5/8	2-3/4	0	-	F	56.5
P112-14M-55	C3	112	19.650	19.540	-	7/8	3-5/8	2-3/4	0	-	F	72.0
P144-14M-55	C3	144	25.264	25.154	-	7/8	3-5/8	2-3/4	0	-	F	98.0
P168-14M-55	C3	168	29.475	29.365	-	7/8	3-5/8	2-3/4	0	-	F	130.0
P192-14M-55	C3	192	33.686	33.576	-	7/8	3-5/8	2-3/4	0	-	F	155.0
P216-14M-55	C3	216	37.896	37.786	-	7/8	3-5/8	2-3/4	0	-	F	210.0

Δ Weights shown are approximate and in some cases may be calculated. Weights do not include bushing.

Pulley Type: F = Flanged

Dimensions shown are for reference purposes only, and are subject to change without notice. Where space requirements are critical, consult IDC-USA® for certified specifications.

SYNCHRONOUS TIMING PULLEYS HTD

14mm PITCH HTD TIMING PULLEYS

14MM Pitch (HT) for 85MM, 115MM and 170MM Wide Belts

Pulley No.	Type	No. of Teeth	Nominal Dimensions								Bushing	Wt. Δ [Approx.] Lbs.
			Pitch Dia.	Pulley OD	Flange OD	E	L	F	M	W		
P30-14M-85	A1F	30	5.263	5.157	5.763	1	4	4	1	3-11/16	SK	9.0
P32-14M-85	A1F	32	5.614	5.507	6.114	1	4	4	1	3-11/16	SK	10.3
P34-14M-85	A1F	34	5.965	5.858	6.465	3/4	1-7/8	4	1-3/8	3-11/16	SK	13.8
P36-14M-85	A1F	36	6.316	6.208	6.816	3/4	1-7/8	4	1-3/8	3-11/16	SF	14.0
P38-14M-85	A1F	38	6.667	6.559	7.167	3/4	1-7/8	4	1-3/8	3-11/16	SF	16.2
P40-14M-85	A1F	40	7.018	6.909	7.518	3/4	2	4	1-1/4	3-11/16	SF	18.2
P44-14M-85	A1F	44	7.720	7.610	8.395	3/4	2	4	1-1/4	3-11/16	E	21.4
P48-14M-85	A1F	48	8.421	8.311	8.941	3/4	2	4	1-1/4	3-11/16	E	28.0
P52-14M-85	A1F	52	9.123	9.013	9.687	5/16	2-5/8	4	1-1/16	3-11/16	E	33.0
P56-14M-85	D1F	56	9.825	9.715	10.355	5/16	2-5/8	4	1-1/16	3-11/16	F	43.8
P60-14M-85	D1F	60	10.527	10.417	11.067	5/16	2-5/8	4	1-1/16	3-11/16	F	52.0
P64-14M-85	D1F	64	11.229	11.119	11.593	1/4	3-5/8	4	5/8	3-11/16	F	60.0
P68-14M-85	D2F	68	11.930	11.820	12.500	1/4	3-5/8	4	5/8	3-11/16	F	53.8
P72-14M-85	D2F	72	12.632	12.522	13.006	1/4	3-5/8	4	5/8	3-11/16	F	58.0
P80-14M-85	D2F	80	14.036	13.926	14.620	1/4	3-5/8	4	5/8	3-11/16	F	65.5
P90-14M-85	D3	90	15.790	15.680	-	1/4	3-5/8	4	5/8	-	F	69.0
P112-14M-85	D3	112	19.650	19.540	-	1/4	3-5/8	4	5/8	-	F	88.0
P144-14M-85	D3	144	25.264	25.154	-	1/4	3-5/8	4	5/8	-	F	125.0
P168-14M-85	D3	168	29.475	29.365	-	1/4	3-5/8	4	5/8	-	J	153.0
P192-14M-85	D3	192	33.686	33.576	-	1/4	3-5/8	4	5/8	-	J	177.0
P216-14M-85	D3	216	37.896	37.786	-	1/4	3-5/8	4	5/8	-	J	215.0
P30-14M-115	A1F	30	5.263	5.157	5.763	1-3/8	1-7/8	5-1/4	2	4-15/16	SK	11.0
P32-14M-115	A1F	32	5.614	5.507	6.114	1-3/8	1-7/8	5-1/4	2	4-15/16	SK	14.5
P34-14M-115	A1F	34	5.965	5.858	6.465	1-3/8	1-7/8	5-1/4	2	4-15/16	SK	18.3
P36-14M-115	A1F	36	6.316	6.208	6.816	1-3/8	2	5-1/4	1-7/8	4-15/16	SF	17.0
P38-14M-115	A1F	38	6.667	6.559	7.167	1-3/8	2	5-1/4	1-7/8	4-15/16	SF	21.0
P40-14M-115	A1F	40	7.018	6.909	7.518	1-3/8	2	5-1/4	1-7/8	4-15/16	SF	22.4
P44-14M-115	A1F	44	7.720	7.610	8.395	15/16	2-5/8	5-1/4	1-11/16	4-15/16	E	25.5
P48-14M-115	A1F	48	8.421	8.311	8.941	15/16	2-5/8	5-1/4	1-11/16	4-15/16	E	33.2
P52-14M-115	A1F	52	9.123	9.013	9.687	3/8	3-5/8	5-1/4	1-1/4	4-15/16	F	42.0
P56-14M-115	A1F	56	9.825	9.715	10.355	3/8	3-5/8	5-1/4	1-1/4	4-15/16	F	50.5
P60-14M-115	A1F	60	10.527	10.417	11.067	3/8	3-5/8	5-1/4	1-1/4	4-15/16	F	58.3
P64-14M-115	D1F	64	11.229	11.119	11.593	3/16	4-1/2	5-1/4	15/16	4-15/16	J	72.3
P68-14M-115	D1F	68	11.930	11.820	12.500	3/16	4-1/2	5-1/4	15/16	4-15/16	J	83.2
P72-14M-115	D1F	72	12.622	12.522	13.006	3/16	4-1/2	5-1/4	15/16	4-15/16	J	94.1
P80-14M-115	D2F	80	14.036	13.926	14.620	3/16	4-1/2	5-1/4	15/16	4-15/16	J	90.0
P90-14M-115	D2	90	15.790	15.680	-	3/16	4-1/2	5-1/4	15/16	-	J	83.2
P112-14M-115	D3	112	19.650	19.540	-	3/16	4-1/2	5-1/4	15/16	-	J	121.0
P144-14M-115	D3	144	25.264	25.154	-	3/16	4-1/2	5-1/4	15/16	-	J	168.0
P168-14M-115	D3	168	29.475	29.365	-	3/16	4-1/2	5-1/4	15/16	-	M	198.0
P192-14M-115	D3	192	33.686	33.576	-	3/16	4-1/2	5-1/4	15/16	-	M	235.0
P216-14M-115	D3	216	37.896	37.786	-	3/16	4-1/2	5-1/4	15/16	-	M	340.0
P44-14M-170	A1F	44	7.720	7.610	8.340	2	2-5/8	7-3/8	2-3/4	7-1/16	E	39.2
P48-14M-170	A1F	48	8.421	8.311	8.900	2	2-5/8	7-3/8	2-3/4	7-1/16	E	49.8
P52-14M-170	A1F	52	9.123	9.013	9.680	1-7/16	3-5/8	7-3/8	2-5/16	7-1/16	F	64.5
P56-14M-170	A1F	56	9.825	9.715	10.380	1-7/16	3-5/8	7-3/8	2-5/16	7-1/16	F	73.3
P60-14M-170	A1F	60	10.527	10.417	11.060	15/16	4-1/2	7-3/8	1-15/16	7-1/16	J	93.1
P64-14M-170	A1F	64	11.229	11.119	11.680	15/16	4-1/2	7-3/8	1-15/16	7-1/16	J	103.9
P68-14M-170	A1F	68	11.930	11.820	12.500	15/16	4-1/2	7-3/8	1-15/16	7-1/16	J	115.3
P72-14M-170	A1F	72	12.632	12.522	13.190	15/16	4-1/2	7-3/8	1-15/16	7-1/16	J	128.2
P80-14M-170	A2F	80	14.036	13.926	14.630	15/16	4-1/2	7-3/8	1-15/16	7-1/16	J	119.9
P90-14M-170	A2	90	15.790	15.680	-	15/16	4-1/2	7-3/8	1-15/16	-	J	104.2
P112-14M-170	A3	112	19.650	19.540	-	0	6-3/4	7-3/8	5/8	-	M	205.5
P144-14M-170	A3	144	25.264	25.154	-	0	6-3/4	7-3/8	5/8	-	M	268.1
P168-14M-170	A3	168	29.475	29.365	-	0	6-3/4	7-3/8	5/8	-	M	293.2
P192-14M-170	A3	192	33.686	33.576	-	0	6-3/4	7-3/8	5/8	-	M	334.8
P216-14M-170	A3	216	37.896	37.786	-	0	6-3/4	7-3/8	5/8	-	M	334.8

Δ Weights shown are approximate and in some cases may be calculated. Weights do not include bushing.

Pulley Type: F = Flanged

Dimensions shown are for reference purposes only, and are subject to change without notice.
Where space requirements are critical, consult IDC-USA® for certified specifications.



Nominal Dimensions

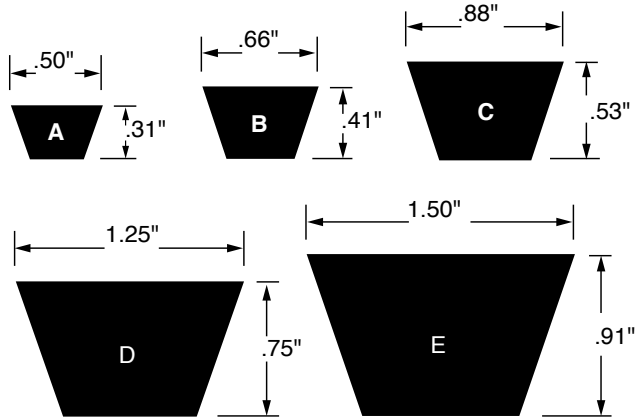

A Section

Belt No.	Wt. Δ (Approx.) Lbs.	Outside Length (Inches)	Datum Length (Inches)
A19	0.123	21	20.3
A20	0.129	22	21.3
A21	0.135	23	22.3
A22	0.142	24	23.3
A23	0.148	25	24.3
A24	0.155	26	25.3
A25	0.161	27	26.3
A26	0.168	28	27.3
A27	0.174	29	28.3
A28	0.181	30	29.3
A29	0.187	31	30.3
A30	0.194	32	31.3
A31	0.200	33	32.3
A32	0.206	34	33.3
A33	0.213	35	34.3
A34	0.219	36	35.3
A35	0.226	37	36.3
A36	0.232	38	37.3
A37	0.239	39	38.3
A38	0.245	40	39.3
A39	0.252	41	40.3
A40	0.258	42	41.3
A41	0.264	43	42.3
A42	0.271	44	43.3
A43	0.277	45	44.3
A44	0.284	46	45.3
A45	0.290	47	46.3
A46	0.297	48	47.3
A47	0.303	49	48.3
A48	0.310	50	49.3
A49	0.316	51	50.3
A50	0.323	52	51.3
A51	0.329	53	52.3
A52	0.335	54	53.3
A53	0.342	55	54.3
A54	0.348	56	55.3
A55	0.355	57	56.3
A56	0.361	58	57.3
A57	0.368	59	58.3
A58	0.374	60	59.3
A59	0.381	61	60.3
A60	0.387	62	61.3
A61	0.393	63	62.3
A62	0.400	64	63.3
A63	0.406	65	64.3
A64	0.413	66	65.3
A65	0.419	67	66.3
A66	0.426	68	67.3
A67	0.432	69	68.3

Belt No.	Wt. Δ (Approx.) Lbs.	Outside Length (Inches)	Datum Length (Inches)
A68	0.439	70	69.3
A69	0.445	71	70.3
A70	0.452	72	71.3
A71	0.458	73	72.3
A72	0.464	74	73.3
A73	0.471	75	74.3
A74	0.477	76	75.3
A75	0.484	77	76.3
A76	0.490	78	77.3
A77	0.497	79	78.3
A78	0.503	80	79.3
A79	0.510	81	80.3
A80	0.516	82	81.3
A81	0.522	83	82.3
A82	0.529	84	83.3
A83	0.535	85	84.3
A84	0.542	86	85.3
A85	0.548	87	86.3
A86	0.555	88	87.3
A87	0.561	89	88.3
A88	0.568	90	89.3
A89	0.574	91	90.3
A90	0.581	92	91.3
A91	0.587	93	92.3
A92	0.593	94	93.3
A93	0.600	95	94.3
A94	0.606	96	95.3
A95	0.613	97	96.3
A96	0.619	98	97.3
A97	0.626	99	98.3
A98	0.632	100	99.3
A99	0.639	101	100.3
A100	0.645	102	101.3
A101	0.651	103	102.3
A102	0.658	104	103.3
A103	0.664	105	104.3
A105	0.677	107	106.3
A110	0.710	112	111.3
A112	0.722	114	113.3
A115	0.742	117	116.3
A120	0.774	122	121.3
A128	0.826	130	129.3
A133	0.858	135	134.3
A136	0.877	138	137.3
A144	0.929	146	145.3
A158	1.019	160	159.3
A173	1.116	175	174.3
A180	1.161	182	181.3

Δ Weights shown are approximate and in some cases may be calculated.

For intermediate sizes not shown, consult IDC-USA® for availability and price.

B Section

Belt No.	Wt. Δ (Approx.) Lbs.	Outside Length (Inches)	Datum Length (Inches)
B25	0.263	28	26.8
B26	0.274	29	27.8
B27	0.284	30	28.8
B28	0.295	31	29.8
B29	0.305	32	30.8
B30	0.316	33	31.8
B31	0.326	34	32.8
B32	0.337	35	33.8
B33	0.347	36	34.8
B34	0.358	37	35.8
B35	0.368	38	36.8
B36	0.379	39	37.8
B37	0.389	40	38.8
B38	0.400	41	39.8
B39	0.410	42	40.8
B40	0.421	43	41.8
B41	0.431	44	42.8
B42	0.442	45	43.8
B43	0.452	46	44.8
B44	0.463	47	45.8
B45	0.473	48	46.8
B46	0.484	49	47.8
B47	0.494	50	48.8
B48	0.505	51	49.8
B49	0.515	52	50.8
B50	0.526	53	51.8
B51	0.537	54	52.8
B52	0.547	55	53.8
B53	0.558	56	54.8
B54	0.568	57	55.8
B55	0.579	58	56.8
B56	0.589	59	57.8
B57	0.600	60	58.8
B58	0.610	61	59.8
B59	0.621	62	60.8
B60	0.631	63	61.8
B61	0.642	64	62.8
B62	0.652	65	63.8
B63	0.663	66	64.8
B64	0.673	67	65.8
B65	0.684	68	66.8
B66	0.694	69	67.8
B67	0.705	70	68.8
B68	0.715	71	69.8
B69	0.726	72	70.8
B70	0.736	73	71.8
B71	0.747	74	72.8
B72	0.757	75	73.8
B73	0.768	76	74.8
B74	0.778	77	75.8
B75	0.700	78	76.8
B76	0.800	79	77.8
B77	0.810	80	78.8
B78	0.821	81	79.8
B79	0.831	82	80.8
B80	0.842	83	81.8
B81	0.852	84	82.8
B82	0.863	85	83.8
B83	0.873	86	84.8
B84	0.884	87	85.8
B85	0.894	88	86.8
B86	0.905	89	87.8
B87	0.915	90	88.8
B88	0.926	91	89.8
B89	0.936	92	90.8
B90	0.947	93	91.8

Belt No.	Wt. Δ (Approx.) Lbs.	Outside Length (Inches)	Datum Length (Inches)
B91	0.957	94	92.8
B92	0.968	95	93.8
B93	0.978	96	94.8
B94	0.989	97	95.8
B95	0.999	98	96.8
B96	1.010	99	97.8
B97	1.020	100	98.8
B98	1.031	101	99.8
B99	1.041	102	100.8
B100	1.052	103	101.8
B101	1.063	104	102.8
B102	1.073	105	103.8
B103	1.084	106	104.8
B104	1.094	107	105.8
B105	1.105	108	106.8
B107	1.126	110	108.8
B108	1.136	111	109.8
B110	1.157	113	111.8
B111	1.168	114	112.8
B112	1.178	115	113.8
B114	1.199	117	115.8
B115	1.210	118	116.8
B116	1.220	119	117.8
B117	1.231	120	118.8
B118	1.241	121	119.8
B120	1.262	123	121.8
B123	1.294	126	124.8
B124	1.304	127	125.8
B126	1.326	129	127.8
B128	1.347	131	129.8
B131	1.378	134	132.8
B133	1.399	136	134.8
B134	1.410	137	135.8
B136	1.431	139	137.8
B140	1.473	143	141.8
B142	1.494	145	143.8
B144	1.515	147	145.8
B147	1.546	150	148.8
B148	1.557	151	149.8
B150	1.578	153	151.8
B152	1.599	155	153.8
B153	1.610	156	154.8
B154	1.620	154	155.8
B158	1.662	161	159.8
B162	1.704	165	163.8
B168	1.767	171	169.8
B173	1.820	176	174.8
B175	1.500	178	176.8
B180	1.894	183	181.8
B185	1.946	188	186.8
B190	1.999	193	191.8
B195	2.051	198	196.8
B205	2.157	208	206.8
B206	2.167	209	207.8
B210	2.209	213	211.8
B225	2.367	226	225.3
B237	2.493	238	237.3
B240	2.525	241	240.3
B255	2.683	256	255.3
B270	2.840	271	270.3
B285	2.998	286	285.3
B292	3.072	293	292.3
B293	3.082	294	293.3
B300	3.156	301	300.3
B315	3.314	316	315.3
B472	4.970	475	473.8

Δ Weights shown are approximate and in some cases may be calculated.

For intermediate sizes not shown, consult IDC-USA® for availability and price.

C Section

Belt No.	Wt. Δ (Approx.) Lbs.	Outside Length (Inches)	Datum Length (Inches)
C51	0.916	55	53.9
C55	0.988	59	57.9
C60	1.078	64	62.9
C62	1.114	66	64.9
C64	1.150	68	66.9
C65	1.168	69	67.9
C68	1.222	72	70.9
C70	1.258	74	72.9
C71	1.276	75	73.9
C72	1.294	76	74.9
C75	1.348	79	77.9
C76	1.366	80	78.9
C78	1.402	82	80.9
C79	1.430	83	81.9
C81	1.456	85	83.9
C82	1.474	86	84.9
C83	1.492	87	85.9
C85	1.527	89	87.9
C90	1.617	94	92.9
C93	1.671	97	95.9
C96	1.725	100	98.9
C97	1.743	101	99.9
C98	1.700	102	100.9
C99	1.779	103	101.9
C100	1.797	104	102.9
C103	1.800	107	105.9
C104	1.869	108	106.9
C105	1.887	109	107.9
C106	1.905	110	108.9
C107	1.923	111	109.9
C108	1.941	112	110.9
C109	1.959	113	111.9
C110	1.977	114	112.9
C111	1.995	115	113.9
C112	2.013	116	114.9
C115	2.067	119	117.9
C117	2.102	121	119.9
C118	2.120	122	120.9
C120	2.156	124	122.9
C124	2.228	128	126.9
C125	2.246	129	127.9

Belt No.	Wt. Δ (Approx.) Lbs.	Outside Length (Inches)	Datum Length (Inches)
C128	2.300	132	130.97
C131	2.354	135	133.9
C132	2.300	136	134.9
C135	2.400	139	137.9
C136	2.444	140	138.9
C140	2.516	144	142.9
C141	2.534	145	143.9
C144	2.588	148	146.9
C147	2.640	151	149.9
C148	2.660	152	150.9
C150	2.696	154	152.9
C151	2.710	155	153.9
C152	2.731	156	154.9
C156	2.800	160	158.9
C158	2.839	162	160.9
C162	2.911	166	164.9
C169	3.040	173	171.9
C170	3.060	174	172.9
C173	3.109	177	175.9
C175	3.145	179	177.9
C177	3.181	181	179.9
C180	3.235	184	182.9
C185	3.324	189	187.9
C190	3.414	194	192.9
C195	3.504	199	197.9
C206	3.702	210	208.9
C210	3.774	214	212.9
C225	4.043	227	225.9
C240	4.800	242	240.9
C255	5.000	257	255.9
C270	4.852	272	270.9
C285	5.121	287	285.9
C300	5.391	302	300.9
C315	5.661	317	315.9
C330	5.930	332	330.9
C345	6.200	347	345.9
C360	6.469	362	360.9
C390	7.008	392	390.9
C420	7.547	422	420.9
C450	8.087	452	450.9
C480	8.626	482	480.9

D Section

Belt No.	Wt. Δ (Approx.) Lbs.	Outside Length (Inches)	Datum Length (Inches)
D120	4.488	125	123.3
D128	4.787	133	131.3
D144	5.386	149	147.3
D158	5.909	163	161.3
D162	6.059	167	165.3
D171	6.395	176	174.3
D173	6.470	178	176.3
D180	6.732	185	183.3
D195	7.293	200	198.3
D210	7.854	215	213.3
D225	8.415	227	255.8
D240	8.976	242	240.8
D255	9.537	257	255.8

Belt No.	Wt. Δ (Approx.) Lbs.	Outside Length (Inches)	Datum Length (Inches)
D270	10.098	272	270.8
D285	10.659	287	285.8
D300	11.220	302	300.8
D315	11.781	317	315.8
D330	12.342	332	330.8
D345	12.903	347	345.8
D360	13.464	362	360.8
D390	14.586	392	390.8
D420	15.708	422	420.8
D450	16.830	452	450.8
D480	17.952	482	480.8
D540	20.196	542	540.8
D600	22.440	602	600.8

E Section

Belt No.	Wt. Δ (Approx.) Lbs.	Outside Length (Inches)	Datum Length (Inches)
E180	10.642	187	184.5
E195	11.528	202	199.5
E210	12.415	217	214.5
E240	14.189	243	241.0
E270	15.962	273	271.0
E300	17.736	303	301.0
E330	19.510	333	331.0

Belt No.	Wt. Δ (Approx.) Lbs.	Outside Length (Inches)	Datum Length (Inches)
E360	21.283	363	361.0
E390	23.057	393	391.0
E420	24.830	423	421.0
E480	28.378	483	481.0
E540	31.925	543	541.0
E600	35.472	603	601.0

Δ Weights shown are approximate and in some cases may be calculated.

For intermediate sizes not shown, consult IDC-USA® for availability and price.

V-BELTS POWER ACE®

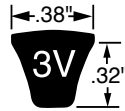

Nominal Dimensions

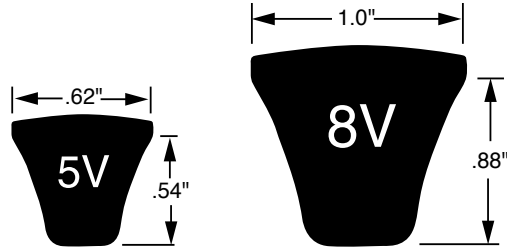

3V Section

Belt No.	Wt. Δ (Approx.) Lbs.	Effective Outside Length (Inches)
3V250	0.114	25.0
3V265	0.121	26.5
3V280	0.128	28.0
3V300	0.137	30.0
3V315	0.144	31.5
3V335	0.153	33.5
3V355	0.162	35.5
3V375	0.172	37.5
3V400	0.183	40.0
3V425	0.194	42.5
3V450	0.206	45.0
3V475	0.217	47.5
3V500	0.229	50.0
3V530	0.243	53.0
3V560	0.256	56.0
3V600	0.275	60.0

Belt No.	Wt. Δ (Approx.) Lbs.	Effective Outside Length (Inches)
3V630	0.288	63.0
3V670	0.307	67.0
3V710	0.325	71.0
3V750	0.343	75.0
3V800	0.366	80.0
3V850	0.389	85.0
3V900	0.412	90.0
3V950	0.435	95.0
3V1000	0.458	100.0
3V1060	0.485	106.0
3V1120	0.513	112.0
3V1180	0.540	118.0
3V1250	0.572	125.0
3V1320	0.604	132.0
3V1400	0.641	140.0

5V Section

Belt No.	Wt. Δ (Approx.) Lbs.	Effective Outside Length (Inches)
5V500	0.648	50
5V530	0.687	53
5V560	0.726	56
5V600	0.778	60
5V630	0.817	63
5V670	0.869	67
5V710	0.921	71
5V750	0.973	75
5V800	1.038	80
5V850	1.102	85
5V900	1.167	90
5V950	1.232	95
5V1000	1.297	100
5V1060	1.375	106
5V1120	1.453	112
5V1180	1.530	118
5V1250	1.621	125
5V1320	1.712	132

Belt No.	Wt. Δ (Approx.) Lbs.	Effective Outside Length (Inches)
5V1400	1.816	140
5V1500	1.945	150
5V1600	2.075	160
5V1700	2.205	170
5V1800	2.334	180
5V1900	2.464	190
5V2000	2.594	200
5V2120	2.749	212
5V2240	2.905	224
5V2360	3.061	236
5V2500	3.242	250
5V2650	3.437	265
5V2800	3.631	280
5V3000	3.891	300
5V3150	4.085	315
5V3350	4.345	335
5V3550	4.604	355

Δ Weights shown are approximate and in some cases may be calculated.

For intermediate sizes not shown, consult IDC-USA® for availability and price.

V-BELTS POWER ACE® AND POWER KING® COG

8V Section

Belt No.	Wt. Δ (Approx.) Lbs.	Effective Outside Length (Inches)
8V1000	3.490	100
8V1060	3.700	106
8V1120	3.909	112
8V1180	4.119	118
8V1250	4.363	125
8V1320	4.607	132
8V1400	4.887	140
8V1500	5.236	150
8V1600	5.585	160
8V1700	5.934	170
8V1800	6.283	180
8V1900	6.632	190
8V2000	6.981	200
8V2120	7.400	212
8V2240	7.818	224

Belt No.	Wt. Δ (Approx.) Lbs.	Effective Outside Length (Inches)
8V2360	8.237	236
8V2500	8.726	250
8V2650	9.250	265
8V2800	9.773	280
8V3000	10.471	300
8V3150	10.995	315
8V3350	11.693	335
8V3550	12.391	355
8V3750	13.089	375
8V4000	13.962	400
8V4250	14.834	425
8V4500	15.707	450
8V4750	16.579	475
8V5000	17.452	500
8V5600	19.546	560



Nominal Dimensions

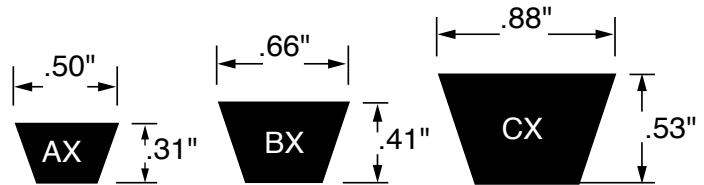

AX Section

Belt No.	Wt. Δ (Approx.) Lbs.	Outside Length (Inches)	Datum Length (Inches)
AX21	0.200	23	22.3
AX24	0.143	26	25.3
AX26	0.155	28	27.3
AX28	0.167	30	29.3
AX29	0.173	31	30.3
AX31	0.185	33	32.3
AX33	0.197	35	34.3
AX34	0.203	36	35.3
AX35	0.209	37	36.3
AX36	0.215	38	37.3
AX37	0.221	39	38.3
AX38	0.227	40	39.3
AX39	0.233	41	40.3
AX40	0.239	42	41.3
AX42	0.251	44	43.3
AX43	0.257	45	44.3
AX44	0.300	46	45.3
AX45	0.268	47	46.3
AX46	0.274	48	47.3
AX48	0.286	50	49.3
AX51	0.304	53	52.3
AX52	0.300	54	53.3
AX53	0.316	55	54.3
AX54	0.322	56	55.3
AX55	0.328	57	56.3
AX56	0.334	58	57.3

Belt No.	Wt. Δ (Approx.) Lbs.	Outside Length (Inches)	Datum Length (Inches)
AX60	0.358	62	61.3
AX62	0.370	64	63.3
AX64	0.382	66	65.3
AX66	0.394	68	67.3
AX68	0.406	70	69.3
AX70	0.418	72	71.3
AX71	0.424	73	72.3
AX73	0.500	75	74.3
AX75	0.447	77	76.3
AX78	0.465	80	79.3
AX80	0.477	82	81.3
AX85	0.507	87	86.3
AX90	0.537	92	91.3
AX92	0.549	94	93.3
AX96	0.573	98	97.3
AX105	0.626	107	106.3
AX110	0.656	112	111.3
AX112	0.668	114	113.3
AX120	0.716	122	121.3
AX128	0.764	130	129.3
AX136	0.811	138	137.3
AX144	0.859	146	145.3
AX158	0.943	160	159.3
AX173	1.032	175	174.3
AX180	1.074	182	181.3

Δ Weights shown are approximate and in some cases may be calculated.
For intermediate sizes not shown, consult IDC-USA® for availability and price.

BX Section

Belt No.	Wt. Δ (Approx.) Lbs.	Outside Length (Inches)	Datum Length (Inches)
BX34	0.348	37	35.8
BX35	0.358	38	36.8
BX36	0.368	39	37.8
BX37	0.379	40	38.8
BX38	0.389	41	39.8
BX40	0.409	43	41.8
BX41	0.420	44	42.8
BX42	0.430	45	43.8
BX43	0.440	46	44.8
BX46	0.471	49	47.8
BX48	0.491	51	49.8
BX50	0.512	53	51.8
BX51	0.522	54	52.8
BX52	0.532	55	53.8
BX53	0.542	56	54.8
BX54	0.553	57	55.8
BX55	0.563	58	56.8
BX56	0.573	59	57.8
BX57	0.600	60	58.8
BX58	0.594	61	59.8
BX59	0.604	62	60.8
BX60	0.614	63	61.8
BX61	0.624	64	62.8
BX62	0.634	65	63.8
BX63	0.645	66	64.8
BX64	0.655	67	65.8
BX65	0.665	68	66.8
BX66	0.675	69	67.8
BX67	0.686	70	68.8
BX68	0.696	71	69.8
BX70	0.716	73	71.8
BX71	0.727	74	72.8
BX75	0.768	78	76.8
BX77	0.788	80	78.8
BX78	0.798	81	79.8

Belt No.	Wt. Δ (Approx.) Lbs.	Outside Length (Inches)	Datum Length (Inches)
BX79	0.808	82	80.8
BX80	0.819	83	81.8
BX81	0.829	84	82.8
BX82	0.839	85	83.8
BX83	0.849	86	84.8
BX85	0.870	88	86.8
BX89	0.900	92	90.8
BX90	0.921	93	91.8
BX93	0.952	96	94.8
BX95	0.972	98	96.8
BX96	0.982	99	97.8
BX97	0.993	100	98.8
BX99	1.013	102	100.8
BX100	1.023	103	101.8
BX103	1.054	106	104.8
BX105	1.075	108	106.8
BX108	1.105	111	109.8
BX112	1.146	115	113.8
BX113	1.156	116	114.8
BX115	1.177	118	116.8
BX116	1.187	119	117.8
BX120	1.228	123	121.8
BX124	1.269	127	125.8
BX128	1.310	131	129.8
BX133	1.361	136	134.8
BX136	1.392	139	137.8
BX144	1.474	147	145.8
BX158	1.617	161	159.8
BX162	1.658	165	163.8
BX173	1.770	176	174.8
BX180	1.842	183	181.8
BX195	1.996	198	196.8
BX210	2.149	213	211.8
BX225	2.303	226	225.3
BX240	2.456	241	240.3

CX Section

Belt No.	Wt. Δ (Approx.) Lbs.	Outside Length (Inches)	Datum Length (Inches)
CX51	0.847	55	53.9
CX60	0.997	64	62.9
CX68	1.129	72	70.9
CX75	1.246	79	77.9
CX81	1.345	85	83.9
CX85	1.412	89	87.9
CX90	1.495	94	92.9
CX96	1.595	100	98.9
CX101	1.678	105	103.9
CX105	1.744	109	107.9
CX109	1.811	113	111.9
CX111	1.844	115	113.9
CX112	1.860	116	114.9
CX115	1.910	119	117.9
CX120	1.993	124	122.9
CX123	2.043	127	125.9

Belt No.	Wt. Δ (Approx.) Lbs.	Outside Length (Inches)	Datum Length (Inches)
CX128	2.126	132	130.9
CX133	2.209	137	135.9
CX136	2.259	140	138.9
CX144	2.392	148	146.9
CX150	2.492	154	152.9
CX158	2.624	162	160.9
CX162	2.691	166	164.9
CX173	2.874	177	175.9
CX180	2.990	184	182.9
CX187	3.106	191	189.9
CX190	3.156	194	192.9
CX195	3.239	199	197.9
CX210	3.488	214	212.9
CX225	3.737	227	225.9
CX240	3.986	242	240.9

Δ Weights shown are approximate and in some cases may be calculated.
For intermediate sizes not shown, consult IDC-USA® for availability and price.



BAN/SET

BANDO

Nominal Dimensions

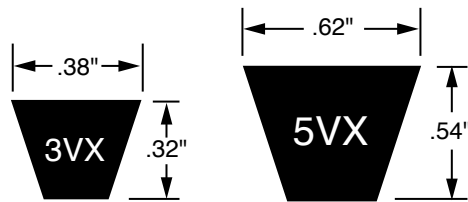

3VX Section

Belt No.	Wt. Δ (Approx.) Lbs.	Effective Outside Length (Inches)
3VX250	0.105	25.0
3VX265	0.111	26.5
3VX280	0.118	28.0
3VX300	0.126	30.0
3VX315	0.132	31.5
3VX335	0.141	33.5
3VX355	0.149	35.5
3VX375	0.158	37.5
3VX400	0.168	40.0
3VX425	0.179	42.5
3VX450	0.189	45.0
3VX475	0.200	47.5
3VX500	0.210	50.0
3VX530	0.223	53.0
3VX560	0.235	56.0
3VX600	0.252	60.0

Belt No.	Wt. Δ (Approx.) Lbs.	Effective Outside Length (Inches)
3VX630	0.265	63.0
3VX670	0.281	67.0
3VX710	0.298	71.0
3VX750	0.315	75.0
3VX800	0.336	80.0
3VX850	0.357	85.0
3VX900	0.378	90.0
3VX950	0.399	95.0
3VX1000	0.420	100.0
3VX1060	0.445	106.0
3VX1120	0.470	112.0
3VX1180	0.496	118.0
3VX1250	0.525	125.0
3VX1320	0.554	132.0
3VX1400	0.588	140.0

5VX Section

Belt No.	Wt. Δ (Approx.) Lbs.	Effective Outside Length (Inches)
5VX500	0.506	50.0
5VX530	0.536	53.0
5VX560	0.567	56.0
5VX600	0.607	60.0
5VX630	0.637	63.0
5VX670	0.678	67.0
5VX710	0.718	71.0
5VX750	0.759	75.0
5VX800	0.809	80.0
5VX850	0.860	85.0
5VX900	0.911	90.0
5VX950	0.961	95.0
5VX1000	1.012	100.0

Belt No.	Wt. Δ (Approx.) Lbs.	Effective Outside Length (Inches)
5VX1060	1.072	106.0
5VX1120	1.133	112.0
5VX1180	1.194	118.0
5VX1250	1.265	125.0
5VX1320	1.335	132.0
5VX1400	1.416	140.0
5VX1500	1.518	150.0
5VX1600	1.619	160.0
5VX1700	1.720	170.0
5VX1800	1.821	180.0
5VX1900	1.922	190.0
5VX2000	2.023	200.0

Δ Weights shown are approximate and in some cases may be calculated.
For intermediate sizes not shown, consult IDC-USA® for availability and price.

V-BELTS POWER KING® COMBO



Available in the following ribs — 2, 3, 4, 5, 6, or over

BANDO
BAN/SET

Nominal Dimensions

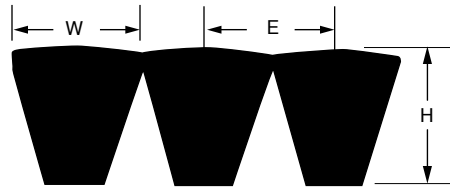

Belt Section	Top Width W (Inches)	Thickness H (Inches)	Pitch Between Belts E (Inches)
B	.66	.51	.75
C	.88	.63	1.00
D	1.25	.85	1.46

B Section

Belt No.	Wt. Δ (Approx.) Lbs.	Outside Length (Inches)	Datum Length (Inches)
B46	0.790	49.75	47.80
B48	0.820	51.75	49.80
B50	0.850	53.75	51.80
B51	0.870	54.75	52.80
B52	0.890	55.75	53.80
B53	0.900	56.75	54.80
B54	0.920	57.75	55.80
B55	0.940	58.75	56.80
B56	0.960	59.75	57.80
B57	0.970	60.75	58.80
B58	0.990	61.75	59.80
B59	1.010	62.75	60.80
B60	1.020	63.75	61.80
B61	1.040	64.75	62.80
B62	1.060	65.75	63.80
B63	1.070	66.75	64.80
B64	1.090	67.75	65.80
B65	1.110	68.75	66.80
B66	1.130	69.75	67.80
B67	1.140	70.75	68.80
B68	1.160	71.75	69.80
B70	1.190	73.75	71.80
B71	1.210	74.75	72.80
B72	1.230	75.75	73.80
B73	1.240	76.75	74.80
B74	1.260	77.75	75.80
B75	1.280	78.75	76.80
B77	1.310	80.75	78.80
B78	1.330	81.75	79.80
B79	1.350	82.75	80.80
B80	1.360	83.75	81.80
B81	1.380	84.75	82.80

Belt No.	Wt. Δ (Approx.) Lbs.	Outside Length (Inches)	Datum Length (Inches)
B82	1.400	85.75	83.80
B83	1.420	86.75	84.80
B85	1.450	88.75	86.80
B87	1.480	90.75	88.80
B90	1.530	93.75	91.80
B93	1.590	96.75	94.80
B95	1.620	98.75	96.80
B96	1.640	99.75	97.80
B97	1.650	100.75	98.80
B99	1.690	102.75	100.80
B100	1.700	103.75	101.80
B103	1.760	106.75	104.80
B105	1.790	108.75	106.80
B108	1.840	111.75	109.80
B112	1.910	115.75	113.80
B116	2.000	119.75	117.80
B120	2.040	123.75	121.80
B124	2.110	127.75	125.80
B128	2.180	131.75	129.80
B133	2.270	136.75	134.80
B136	2.320	139.75	137.80
B144	2.450	147.75	145.80
B148	2.520	151.75	149.80
B150	2.560	153.75	155.70
B158	2.700	161.75	159.80
B162	2.760	165.75	163.80
B173	2.950	176.75	174.80
B180	3.070	183.75	181.80
B195	3.320	198.75	196.80
B210	3.580	213.75	211.80
B225	3.830	226.75	225.30
B240	4.090	241.75	240.30

C Section

Belt No.	Wt. Δ (Approx.) Lbs.	Outside Length (Inches)	Datum Length (Inches)
C85	2.410	89.88	87.90
C90	2.550	94.88	92.90
C96	2.720	100.88	98.90
C100	2.830	104.88	102.90
C105	2.970	109.88	107.90
C108	3.050	112.88	110.90
C109	3.080	113.88	111.90
C112	3.160	116.88	114.90
C120	3.390	124.88	122.90
C123	3.470	127.88	125.90
C124	3.500	128.88	126.90
C128	3.620	132.88	130.90
C136	3.840	140.88	138.90
C144	4.070	148.88	146.90
C158	4.460	162.88	160.90
C162	4.580	166.88	164.90

Belt No.	Wt. Δ (Approx.) Lbs.	Outside Length (Inches)	Datum Length (Inches)
C173	4.890	177.88	175.90
C180	5.080	184.88	182.90
C195	5.510	199.88	197.90
C210	5.930	214.88	212.90
C225	6.350	227.88	225.90
C240	6.780	242.88	240.90
C255	7.200	257.88	255.90
C270	7.620	272.88	270.90
C285	8.050	287.88	285.90
C300	8.470	302.88	300.90
C315	8.890	317.88	315.90
C330	9.320	332.88	330.90
C345	9.740	347.88	345.90
C360	10.170	362.88	360.90
C390	11.010	392.88	390.90
C420	11.860	422.88	420.90

Δ Weights shown are approximate and in some cases may be calculated.

For intermediate sizes not shown, consult IDC-USA® for availability and price.

V-BELTS POWER KING® COMBO

Available in the following ribs — 2, 3, 4, 5, 6, or over



BANDO

BAN/SET

Nominal Dimensions

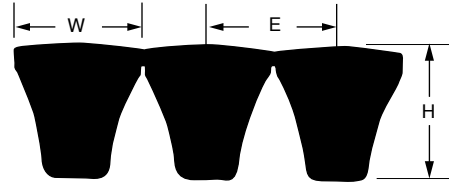

Belt Section	Top Width W (Inches)	Thickness H (Inches)	Pitch Between Belts E (Inches)
3V	.38	.39	.41
5V	.62	.63	.69
8V	1.00	.98	1.13

3V Section

Belt No.	Wt. Rib Δ (Approx.) Lbs.	Nominal Outside Length (Inches)
3V400	0.250	40.63
3V425	0.270	43.13
3V450	0.280	45.63
3V475	0.300	48.13
3V500	0.310	50.63
3V530	0.330	53.63
3V560	0.350	56.63
3V600	0.380	60.63
3V630	0.400	63.63
3V670	0.420	67.63
3V710	0.450	71.63
3V750	0.470	75.63
3V800	0.500	80.63
3V850	0.530	85.63
3V900	0.560	90.63
3V950	0.600	95.63
3V100	0.630	100.63
3V106	0.660	106.63
3V112	0.700	112.63
3V118	0.740	118.63
3V125	0.780	125.63
3V132	0.830	132.63
3V140	0.880	140.63

5V Section

Belt No.	Wt. Rib Δ (Approx.) Lbs.	Nominal Outside Length (Inches)
5V500	0.800	50.75
5V530	0.840	53.75
5V560	0.890	56.75
5V600	0.950	60.75
75V630	1.000	63.75
5V670	1.070	67.75
5V710	1.130	71.75
5V750	1.190	75.75
5V800	1.270	80.75
5V850	1.350	85.75
5V900	1.430	90.75
5V950	1.510	95.75
5V1000	1.590	100.75
5V1060	1.690	106.75
5V1120	1.780	112.75
5V1180	1.880	118.75
5V1250	1.990	125.75
5V1320	2.100	132.75
5V1400	2.230	140.75
5V1500	2.390	150.75
5V1600	2.540	160.75
5V1700	2.700	170.75
5V1800	2.860	180.75
5V1900	3.020	190.75
5V2000	3.180	200.75
5V2120	3.370	212.75
5V2240	3.560	224.75
5V2360	3.750	236.75
5V2500	3.980	250.75
5V2650	4.210	265.75
5V2800	4.450	280.75
5V3000	4.770	300.75
5V3150	5.010	315.75
5V3350	5.330	335.75
5V3550	5.640	355.75

8V Section

Belt No.	Wt. Δ (Approx.) Lbs.	Effective Outside Length (Inches)
8V1000	3.990	101.00
8V1060	4.220	107.00
8V1120	4.460	113.00
8V1180	4.700	119.00
8V1250	4.980	126.00
8V1320	5.260	133.00
8V1400	5.580	141.00
8V1500	5.980	151.00
8V1600	6.380	161.00
8V1700	6.770	171.00
8V1800	7.170	181.00
8V1900	7.570	191.00
8V2000	7.970	201.00
8V2120	8.450	213.00
8V2240	8.920	225.00
8V2360	9.400	237.00
8V2500	9.960	251.00
8V2650	10.560	266.00
8V2800	11.150	281.00
8V3000	11.950	301.00
8V3150	12.550	316.00
8V3350	13.350	336.00
8V3550	14.140	356.00
8V3750	14.940	376.00
8V4000	15.930	401.00
8V4250	16.930	426.00
8V4500	17.930	451.00
8V4750	18.920	476.00
8V5000	19.920	501.00
8V5600	22.310	561.00
8V6000	23.900	601.00

Δ Weights shown are approximate and in some cases may be calculated.
For intermediate sizes not shown, consult IDC-USA® for availability and price.

V-BELTS DOUBLE

AA Section

Belt No.	Wt. Δ (Approx.) Lbs.	Outside Length (Inches)
AA45	0.30	47.10
AA51	0.40	53.10
AA55	0.40	57.10
AA60	0.50	62.10
AA62	0.50	64.10
AA64	0.50	66.10
AA66	0.50	68.10
AA68	0.50	70.10
AA70	0.60	72.10
AA75	0.60	77.10
AA77	0.60	79.10
AA78	0.60	80.10
AA80	0.60	82.10
AA85	0.60	87.10
AA90	0.70	92.10
AA96	0.70	98.10
AA105	0.80	107.10
AA112	0.80	114.10
AA120	0.90	122.10
AA128	0.90	130.10
AA136	1.00	138.10
AA144	1.00	146.10



Nominal Dimensions

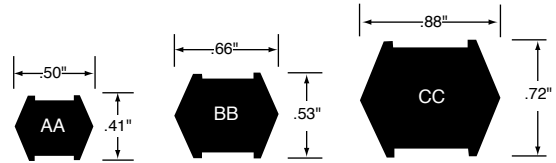

BB Section (continued)

Belt No.	Wt. Δ (Approx.) Lbs.	Outside Length (Inches)
BB107	1.30	109.90
BB108	1.30	110.90
BB111	1.40	113.90
BB112	1.40	114.90
BB116	1.40	118.90
BB117	1.40	119.90
BB118	1.50	120.90
BB120	1.50	122.90
BB122	1.50	124.90
BB123	1.50	125.90
BB124	1.50	126.90
BB127	1.60	129.90
BB128	1.60	130.90
BB129	1.60	131.90
BB130	1.70	132.90
BB136	1.80	138.90
BB140	1.80	142.90
BB144	1.80	146.90
BB148	1.80	150.90
BB155	2.00	157.90
BB157	2.00	159.90
BB158	2.00	160.90
BB159	2.00	161.90
BB162	2.10	164.90
BB168	2.10	170.90
BB169	2.10	171.90
BB173	2.10	175.90
BB175	2.10	177.90
BB180	2.20	182.90
BB182	2.20	184.90
BB190	2.30	192.90
BB195	2.40	197.90
BB210	2.60	212.90
BB225	2.80	226.40
BB226	2.80	227.40
BB228	2.90	229.40
BB230	2.90	231.40
BB240	2.90	241.40
BB270	3.30	271.40
BB273	3.30	274.40
BB277	3.50	278.40
BB278	3.50	279.40
BB300	3.70	301.40

CC Section

Belt No.	Wt. Δ (Approx.) Lbs.	Outside Length (Inches)
CC75	1.60	79.20
CC81	1.80	85.20
CC85	1.90	89.20
CC90	2.00	94.20
CC96	2.20	100.20
CC105	2.40	109.20
CC112	2.50	116.20
CC119	2.70	123.20
CC120	2.70	124.20
CC128	2.90	132.20
CC136	3.10	140.20
CC144	3.20	148.20
CC150	3.20	154.20
CC155	3.20	159.20
CC158	3.50	162.20
CC162	3.80	166.20
CC173	3.80	177.20
CC180	4.00	184.20
CC195	4.30	199.20
CC210	4.70	214.20
CC240	5.20	242.20
CC270	5.90	272.20
CC300	6.50	302.20
CC330	7.20	332.20
CC360	7.80	362.20
CC390	8.50	392.20
CC420	9.10	422.20

BB Section

Belt No.	Wt. Δ (Approx.) Lbs.	Outside Length (Inches)
BB43	0.60	45.90
BB45	0.60	47.90
BB46	0.60	48.90
BB51	0.70	53.90
BB53	0.70	55.90
BB54	0.70	56.90
BB55	0.70	57.90
BB60	0.80	62.90
BB63	0.80	65.90
BB68	0.90	70.90
BB71	1.00	73.90
BB73	1.00	75.90
BB74	1.00	76.90
BB75	1.00	77.90
BB76	1.00	78.90
BB77	1.00	79.90
BB81	1.00	83.90
BB82	1.00	84.90
BB83	1.00	85.90
BB85	1.10	87.90
BB90	1.10	92.90
BB92	1.10	94.90
BB93	1.20	95.90
BB94	1.20	96.90
BB97	1.20	99.90
BB103	1.30	105.90
BB105	1.30	107.90

Δ Weights shown are approximate and in some cases may be calculated.

For intermediate sizes not shown, consult IDC-USA® for availability and price.

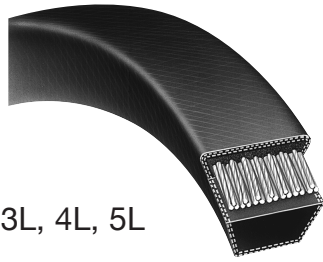

3L, 4L, 5L

3L Section

Belt No.	Wt. Δ (Approx.) Lbs.	Outside Length (Inches)
3L110	0.037	11.0
3L120	0.040	12.0
3L130	0.044	13.0
3L140	0.047	14.0
3L150	0.051	15.0
3L160	0.054	16.0
3L170	0.057	17.0
3L180	0.061	18.0
3L190	0.064	19.0
3L200	0.067	20.0
3L210	0.071	21.0
3L220	0.074	22.0
3L230	0.077	23.0
3L240	0.081	24.0
3L250	0.084	25.0
3L260	0.088	26.0
3L270	0.091	27.0
3L280	0.094	28.0
3L290	0.098	29.0
3L300	0.101	30.0
3L310	0.104	31.0
3L320	0.108	32.0
3L330	0.111	33.0
3L340	0.115	34.0
3L350	0.118	35.0
3L360	0.121	36.0
3L370	0.125	37.0
3L380	0.128	38.0
3L390	0.131	39.0
3L400	0.135	40.0
3L410	0.138	41.0
3L420	0.141	42.0
3L430	0.145	43.0
3L440	0.148	44.0
3L450	0.152	45.0
3L460	0.155	46.0
3L470	0.158	47.0
3L480	0.162	48.0
3L490	0.165	49.0
3L500	0.168	50.0
3L510	0.172	51.0
3L520	0.175	52.0
3L530	0.179	53.0
3L540	0.182	54.0
3L550	0.185	55.0
3L560	0.189	56.0
3L570	0.192	57.0
3L580	0.195	58.0
3L590	0.199	59.0
3L600	0.202	60.0
3L610	0.205	61.0
3L620	0.209	62.0
3L630	0.212	63.0
3L640	0.216	64.0
3L650	0.219	65.0
3L660	0.222	66.0
3L670	0.226	67.0

Nominal Dimensions

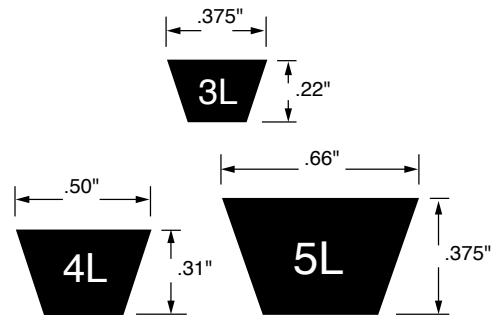

3L Section (continued)

Belt No.	Wt. Δ (Approx.) Lbs.	Outside Length (Inches)
3L680	0.229	68.0
3L690	0.232	69.0
3L700	0.236	70.0
3L710	0.239	71.0
3L720	0.242	72.0
3L730	0.246	73.0
3L740	0.249	74.0

4L Section

Belt No.	Wt. Δ (Approx.) Lbs.	Outside Length (Inches)
4L150	0.090	15.0
4L160	0.096	16.0
4L170	0.102	17.0
4L180	0.109	18.0
4L190	0.115	19.0
4L200	0.121	20.0
4L210	0.127	21.0
4L220	0.133	22.0
4L230	0.139	23.0
4L240	0.145	24.0
4L250	0.151	25.0
4L260	0.157	26.0
4L270	0.163	27.0
4L280	0.169	28.0
4L290	0.175	29.0
4L300	0.181	30.0
4L310	0.187	31.0
4L320	0.193	32.0
4L330	0.199	33.0
4L340	0.205	34.0
4L350	0.211	35.0
4L360	0.217	36.0
4L370	0.223	37.0
4L380	0.229	38.0
4L390	0.235	39.0
4L400	0.241	40.0
4L410	0.247	41.0
4L415	0.250	41.5
4L420	0.253	42.0
4L430	0.259	43.0
4L440	0.265	44.0
4L450	0.271	45.0
4L460	0.277	46.0
4L470	0.283	47.0
4L480	0.289	48.0
4L490	0.295	49.0
4L500	0.301	50.0

Δ Weights shown are approximate and in some cases may be calculated.
For intermediate sizes not shown, consult IDC-USA® for availability and price.

V-BELTS DURAFLEX GL[®] FHP

4L Section (continued)

Belt No.	Wt. Δ (Approx.) Lbs.	Outside Length (Inches)
4L510	0.307	51.0
4L520	0.313	52.0
4L530	0.319	53.0
4L540	0.326	54.0
4L550	0.332	55.0
4L560	0.338	56.0
4L570	0.344	57.0
4L580	0.350	58.0
4L590	0.356	59.0
4L600	0.362	60.0
4L610	0.368	61.0
4L620	0.374	62.0
4L630	0.380	63.0
4L640	0.386	64.0
4L650	0.392	65.0
4L660	0.398	66.0
4L670	0.404	67.0
4L680	0.410	68.0
4L690	0.416	69.0
4L700	0.422	70.0
4L710	0.428	71.0
4L720	0.434	72.0
4L730	0.440	73.0
4L740	0.446	74.0
4L750	0.452	75.0
4L760	0.458	76.0
4L770	0.464	77.0
4L780	0.470	78.0
4L790	0.476	79.0
4L800	0.482	80.0
4L810	0.488	81.0
4L820	0.494	82.0
4L830	0.500	83.0
4L840	0.506	84.0
4L850	0.512	85.0
4L860	0.518	86.0
4L870	0.524	87.0
4L880	0.530	88.0
4L890	0.536	89.0
4L900	0.543	90.0
4L910	0.549	91.0
4L920	0.555	92.0
4L930	0.561	93.0
4L940	0.567	94.0
4L950	0.573	95.0
4L960	0.579	96.0
4L970	0.585	97.0
4L980	0.591	98.0
4L990	0.597	99.0
4L1000	0.603	100.0

5L Section (continued)

Belt No.	Wt. Δ (Approx.) Lbs.	Outside Length (Inches)
5L330	0.302	33.0
5L340	0.311	34.0
5L350	0.320	35.0
5L360	0.329	36.0
5L370	0.338	37.0
5L380	0.347	38.0
5L390	0.357	39.0
5L400	0.366	40.0
5L410	0.375	41.0
5L420	0.384	42.0
5L430	0.393	43.0
5L440	0.402	44.0
5L450	0.411	45.0
5L460	0.421	46.0
5L470	0.430	47.0
5L480	0.439	48.0
5L490	0.448	49.0
5L500	0.457	50.0
5L510	0.466	51.0
5L520	0.475	52.0
5L530	0.485	53.0
5L540	0.494	54.0
5L550	0.503	55.0
5L560	0.512	56.0
5L570	0.521	57.0
5L580	0.530	58.0
5L590	0.539	59.0
5L600	0.549	60.0
5L610	0.558	61.0
5L620	0.567	62.0
5L630	0.576	63.0
5L640	0.585	64.0
5L650	0.594	65.0
5L660	0.603	66.0
5L670	0.613	67.0
5L680	0.622	68.0
5L690	0.631	69.0
5L700	0.640	70.0
5L710	0.649	71.0
5L720	0.658	72.0
5L730	0.667	73.0
5L740	0.677	74.0
5L750	0.686	75.0
5L760	0.695	76.0
5L770	0.704	77.0
5L780	0.713	78.0
5L790	0.722	79.0
5L800	0.731	80.0
5L810	0.741	81.0
5L820	0.750	82.0
5L830	0.759	83.0
5L840	0.768	84.0
5L850	0.777	85.0
5L860	0.786	86.0
5L870	0.795	87.0
5L880	0.804	88.0
5L890	0.814	89.0
5L900	0.823	90.0
5L910	0.832	91.0
5L920	0.841	92.0
5L930	0.850	93.0
5L940	0.859	94.0
5L950	0.868	95.0
5L960	0.878	96.0
5L970	0.887	97.0
5L980	0.896	98.0
5L990	0.905	99.0
5L1000	0.914	100.0

5L Section

Belt No.	Wt. Δ (Approx.) Lbs.	Outside Length (Inches)
5L230	0.210	23.0
5L240	0.219	24.0
5L250	0.229	25.0
5L260	0.238	26.0
5L270	0.247	27.0
5L280	0.256	28.0
5L290	0.265	29.0
5L300	0.274	30.0
5L310	0.283	31.0
5L320	0.293	32.0

Δ Weights shown are approximate and in some cases may be calculated.
For intermediate sizes not shown, consult IDC-USA[®] for availability and price.

TIMING BELTS SYNCHRO-LINK®



BANDO

Nominal Dimensions

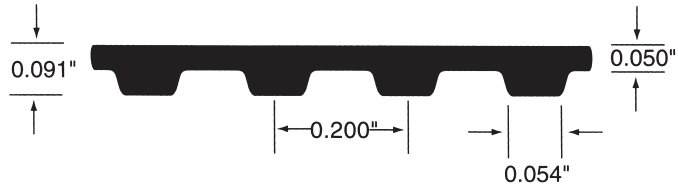

1/5 Inch Pitch (XL) for 1/4" and 3/8" Wide Belts

Belt No.	Wt. Δ (Approx.) Lbs.	Pitch Length (Inches)	No. of Teeth
50XL025G	0.004	5.00	25
50XL037G	0.006	5.00	25
60XL025G	0.005	6.00	30
60XL037G	0.007	6.00	30
70XL025G	0.005	7.00	35
70XL037G	0.008	7.00	35
72XL025G	0.006	7.20	36
72XL037G	0.008	7.20	36
74XL025G	0.006	7.40	37
74XL037G	0.008	7.40	37
76XL025G	0.006	7.60	38
76XL037G	0.009	7.60	38
78XL025G	0.005	7.80	39
78XL037G	0.009	7.80	39
80XL025G	0.006	8.00	40
80XL037G	0.009	8.00	40
82XL025G	0.006	8.20	41
82XL037G	0.009	8.20	41
84XL025G	0.006	8.40	42
84XL037G	0.009	8.40	42
86XL025G	0.006	8.60	43
86XL037G	0.010	8.60	43
88XL025G	0.007	8.80	44
88XL037G	0.010	8.80	44
90XL025G	0.007	9.00	45
90XL037G	0.010	9.00	45
92XL025G	0.007	9.20	46
92XL037G	0.010	9.20	46
94XL025G	0.007	9.40	47
94XL037G	0.011	9.40	47
96XL025G	0.007	9.60	48
96XL037G	0.011	9.60	48
98XL025G	0.007	9.80	49
98XL037G	0.011	9.80	49
100XL025G	0.007	10.00	50
100XL037G	0.011	10.00	50
102XL025G	0.008	10.20	51
102XL037G	0.011	10.20	51
104XL025G	0.008	10.40	52
104XL037G	0.012	10.40	52
106XL025G	0.008	10.60	53
106XL037G	0.012	10.60	53
108XL025G	0.008	10.80	54
108XL037G	0.012	10.80	54
110XL025G	0.008	11.00	55
110XL037G	0.012	11.00	55
112XL025G	0.008	11.20	56
112XL037G	0.013	11.20	56
114XL025G	0.009	11.40	57
114XL037G	0.013	11.40	57
116XL025G	0.009	11.60	58
116XL037G	0.013	11.60	58
118XL025G	0.009	11.80	59
118XL037G	0.013	11.80	59

Belt No.	Wt. Δ (Approx.) Lbs.	Pitch Length (Inches)	No. of Teeth
120XL025G	0.009	12.00	60
120XL037G	0.013	12.00	60
122XL025G	0.009	12.20	61
122XL037G	0.014	12.20	61
124XL025G	0.009	12.40	62
124XL037G	0.014	12.40	62
126XL025G	0.009	12.60	63
126XL037G	0.014	12.60	63
128XL025G	0.010	12.80	64
128XL037G	0.014	12.80	64
130XL025G	0.010	13.00	65
130XL037G	0.015	13.00	65
134XL025G	0.010	13.40	67
134XL037G	0.015	13.40	67
136XL025G	0.010	13.60	68
136XL037G	0.015	13.60	68
138XL025G	0.010	13.80	69
138XL037G	0.015	13.80	69
140XL025G	0.010	14.00	70
140XL037G	0.016	14.00	70
144XL025G	0.011	14.40	72
144XL037G	0.016	14.40	72
146XL025G	0.011	14.60	73
146XL037G	0.016	14.60	73
148XL025G	0.011	14.80	74
148XL037G	0.017	14.80	74
150XL025G	0.011	15.00	75
150XL037G	0.017	15.00	75
152XL025G	0.011	15.20	76
152XL037G	0.017	15.20	76
154XL025G	0.012	15.40	77
154XL037G	0.017	15.40	77
156XL025G	0.012	15.60	78
156XL037G	0.017	15.60	78
158XL025G	0.012	15.80	79
158XL037G	0.018	15.80	79
160XL025G	0.012	16.00	80
160XL037G	0.018	16.00	80
162XL025G	0.012	16.20	81
162XL037G	0.018	16.20	81
164XL025G	0.012	16.40	82
164XL037G	0.018	16.40	82
166XL025G	0.012	16.60	83
166XL037G	0.019	16.60	83
168XL025G	0.013	16.80	84
168XL037G	0.019	16.80	84
170XL025G	0.013	17.00	85
170XL037G	0.019	17.00	85
172XL025G	0.013	17.20	86
172XL037G	0.019	17.20	86
174XL025G	0.013	17.40	87
174XL037G	0.019	17.40	87
176XL025G	0.013	17.60	88
176XL037G	0.020	17.60	88

Δ Weights shown are approximate and in some cases may be calculated.

For intermediate sizes not shown, consult IDC-USA® for availability and price.

A full range of Synchro-Link® belts are available in single and double-sided configurations in both neoprene and polyurethane construction, RMA and Metric sizes. Consult IDC-USA® for details on your specific requirement.

TIMING BELTS SYNCHRO-LINK®

1/5 Inch Pitch (XL) for 1/4" and 3/8" Wide Belts (Continued)

Belt No.	Wt. Δ (Approx.) Lbs.	Pitch Length (Inches)	No. of Teeth
178XL025G*	0.013	17.80	89
178XL037G*	0.020	17.80	89
180XL025G	0.013	18.00	90
180XL037G	0.020	18.00	90
182XL025G	0.014	18.20	91
182XL037G	0.020	18.20	91
184XL025G	0.014	18.40	92
184XL037G	0.021	18.40	92
188XL025G	0.014	18.80	94
188XL037G	0.021	18.80	94
190XL025G	0.014	19.00	95
190XL037G	0.021	19.00	95
194XL025G	0.014	19.40	97
194XL037G	0.022	19.40	97
196XL025G	0.015	19.60	98
196XL037G	0.022	19.60	98
198XL025G	0.015	19.80	99
198XL037G	0.022	19.80	99
200XL025G	0.015	20.00	100
200XL037G	0.022	20.00	100
202XL025G	0.015	20.20	101
202XL037G	0.023	20.20	101
206XL025G	0.015	20.60	103
206XL037G	0.023	20.60	103
208XL025G	0.016	20.80	104
208XL037G	0.023	20.80	104
210XL025G	0.016	21.00	105
210XL037G	0.023	21.00	105
212XL025G	0.016	21.20	106
212XL037G	0.024	21.20	106
214XL025G	0.016	21.40	107
214XL037G	0.024	21.40	107
220XL025G	0.016	22.00	110
220XL037G	0.025	22.00	110
228XL025G	0.017	22.80	114
228XL037G	0.026	22.80	114
230XL025G	0.017	23.00	115
230XL037G	0.026	23.00	115
234XL025G	0.017	23.40	117
234XL037G	0.026	23.40	117
240XL025G	0.018	24.00	120
240XL037G	0.027	24.00	120
244XL025G	0.018	24.40	122
244XL037G	0.027	24.40	122
248XL025G	0.019	24.80	124
248XL037G	0.028	24.80	124
250XL025G	0.019	25.00	125
250XL037G	0.028	25.00	125
260XL025G	0.019	26.00	130
260XL037G	0.029	26.00	130
262XL025G	0.020	26.20	131
262XL037G	0.029	26.20	131
266XL025G*	0.020	26.60	133
266XL037G*	0.030	26.60	133
270XL025G	0.020	27.00	135
270XL037G	0.030	27.00	135
272XL025G*	0.020	27.20	136
272XL037G*	0.030	27.20	136
274XL025G*	0.020	27.40	137
274XL037G*	0.031	27.40	137
276XL025G	0.021	27.60	138
276XL037G	0.031	27.60	138
280XL025G	0.021	28.00	140
280XL037G	0.031	28.00	140
282XL025G*	0.021	28.20	141
282XL037G*	0.032	28.20	141
286XL025G*	0.021	28.60	143
286XL037G*	0.032	28.60	143
290XL025G	0.022	29.00	145
290XL037G	0.032	29.00	145

Belt No.	Wt. Δ (Approx.) Lbs.	Pitch Length (Inches)	No. of Teeth
296XL025G*	0.022	29.60	148
296XL037G*	0.033	29.60	148
300XL025G	0.022	30.00	150
300XL037G	0.034	30.00	150
306XL025G*	0.023	30.60	153
306XL037G*	0.034	30.60	153
310XL025G	0.023	31.00	155
310XL037G	0.035	31.00	155
314XL025G	0.023	31.40	157
314XL037G	0.035	31.40	157
316XL025G*	0.024	31.60	158
316XL037G*	0.035	31.60	158
320XL025G	0.024	32.00	160
320XL037G	0.036	32.00	160
322XL0251G*	0.024	32.20	161
322XL037G*	0.036	32.20	161
330XL025G	0.025	33.00	165
330XL037G	0.037	33.00	165
340XL025G	0.025	34.00	170
340XL037G	0.038	34.00	170
344XL025G	0.026	34.40	172
344XL037G	0.038	34.40	172
348XL025G	0.026	34.80	174
348XL037G	0.039	34.80	174
350XL025G*	0.026	35.00	175
350XL037G*	0.039	35.00	175
352XL025G	0.026	35.20	176
352XL037G	0.039	35.20	176
356XL025G	0.027	35.60	178
356XL037G	0.040	35.60	178
360XL025G	0.027	36.00	180
360XL037G	0.040	36.00	180
364XL025G	0.027	36.40	182
364XL037G	0.041	36.40	182
370XL025G	0.028	37.00	185
370XL037G	0.041	37.00	185
372XL025G*	0.028	37.20	186
372XL037G*	0.042	37.20	186
376XL025G	0.028	37.60	188
376XL037G	0.042	37.60	188
380XL025G	0.028	38.00	190
380XL037G	0.042	38.00	190
382XL025G	0.028	38.20	191
382XL037G	0.043	38.20	191
384XL025G	0.029	38.40	192
384XL037G	0.043	38.40	192
386XL025G*	0.029	38.60	193
386XL037G*	0.043	38.60	193
388XL025G*	0.029	38.80	194
388XL037G*	0.043	38.80	194
390XL025G	0.029	39.00	195
390XL037G	0.044	39.00	195
392XL025G*	0.029	39.20	196
392XL037G*	0.044	39.20	196
396XL025G	0.030	39.60	198
396XL037G	0.044	39.60	198
400XL025G	0.030	40.00	200
400XL037G	0.045	40.00	200
408XL025G	0.030	40.80	204
408XL037G	0.046	40.80	204
412XL025G	0.031	41.20	206
412XL037G	0.046	41.20	206
414XL025G*	0.031	41.40	207
414XL037G*	0.046	41.40	207
424XL025G	0.032	42.40	212
424XL037G	0.047	42.40	212
430XL025G	0.032	43.00	215
430XL037G	0.048	43.00	215
438XL025G*	0.033	43.80	219
438XL037G*	0.049	43.80	219

Δ Weights shown are approximate and in some cases may be calculated.

For intermediate sizes not shown, consult IDC-USA® for availability and price.

* Consult IDC-USA® for minimum sleeve (quantity) requirements.

A full range of Synchro-Link® belts are available in single and double-sided configurations in both neoprene and polyurethane construction, RMA and Metric sizes. Consult IDC-USA® for details on your specific requirement.

1/5 Inch Pitch (XL) for 1/4" and 3/8" Wide Belts (Continued)

Belt No.	Wt. Δ (Approx.) Lbs.	Pitch Length (Inches)	No. of Teeth
450XL025G	0.034	45.00	225
450XL037G	0.050	45.00	225
456XL025G	0.034	45.60	228
456XL037G	0.051	45.60	228
460XL025G	0.034	46.00	230
460XL037G	0.051	46.00	230
470XL025G*	0.035	47.00	235
470XL037G*	0.053	47.00	235
490XL025G	0.037	49.00	245
490XL037G	0.055	49.00	245
498XL025G*	0.037	49.80	249
498XL037G*	0.056	49.80	249
506XL025G*	0.038	50.60	253
506XL037G*	0.057	50.60	253
510XL025G	0.038	51.00	255
510XL037G	0.057	51.00	255
514XL025G*	0.038	51.40	257
514XL037G*	0.057	51.40	257
564XL025G	0.042	56.40	282
564XL037G	0.063	56.40	282
580XL025G*	0.043	58.00	290
580XL037G*	0.065	58.00	290
592XL025G	0.044	59.20	296
592XL037G	0.066	59.20	296

Belt No.	Wt. Δ (Approx.) Lbs.	Pitch Length (Inches)	No. of Teeth
608XL025G	0.045	60.80	304
608XL037G	0.068	60.80	304
630XL025G	0.047	63.00	315
630XL037G	0.070	63.00	315
638XL025G	0.048	63.80	319
638XL037G	0.071	63.80	319
828XL025G	0.062	82.80	414
828XL037G	0.092	82.80	414
860XL025G	0.064	86.00	430
860XL037G	0.096	86.00	430
888XL025G	0.066	88.80	444
888XL037G	0.099	88.80	444
900XL025G	0.067	90.00	450
900XL037G	0.101	90.00	450
912XL025G	0.068	91.20	456
912XL037G	0.102	91.20	456
914XL025G	0.068	91.40	457
914XL037G	0.102	91.40	457
926XL025G	0.069	92.60	463
926XL037G	0.103	92.60	463
1014XL025G*	0.076	101.40	507
1014XL037G*	0.113	101.40	507
1020XL025G	0.076	102.00	510
1020XL037G	0.114	102.00	510

* Consult IDC-USA® for minimum sleeve (quantity) requirements.

Δ Weights shown are approximate and in some cases may be calculated.

For intermediate sizes not shown, consult IDC-USA® for availability and price.

A full range of Synchro-Link® belts are available in single and double-sided configurations in both neoprene and polyurethane construction, RMA and Metric sizes. Consult IDC-USA® for details on your specific requirement.

TIMING BELTS SYNCHRO-LINK®



BANDO

Nominal Dimensions

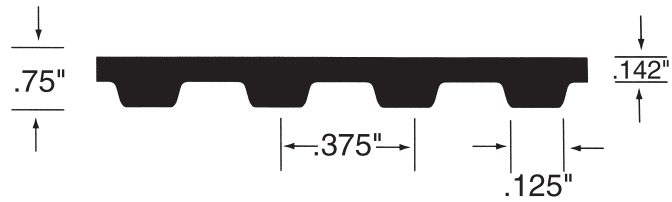

3/8 Inch Pitch (L) 1/2", 3/4" and 1.0" Wide Belts

Belt No.	Wt. Δ (Approx.) Lbs.	Pitch Length (Inches)	No. of Teeth
98L050G	0.023	9.75	26
98L075G	0.034	9.75	26
98L100G	0.046	9.75	26
124L050G	0.029	12.38	33
124L075G	0.044	12.38	33
124L100G	0.058	12.38	33
135L050G	0.032	13.50	36
135L075G	0.047	13.50	36
135L100G	0.063	13.50	36
150L050G	0.035	15.00	40
150L075G	0.053	15.00	40
150L100G	0.070	15.00	40
165L050G	0.039	16.50	44
165L075G	0.058	16.50	44
165L100G	0.077	16.50	44
169L050G	0.040	16.90	45
169L075G	0.059	16.90	45
169L100G	0.079	16.90	45
172L050G	0.040	17.20	46
172L075G	0.061	17.20	46
172L100G	0.081	17.20	46
187L050G	0.044	18.75	50
187L075G	0.066	18.75	50
187L100G	0.088	18.75	50
203L050G	0.048	20.30	54
203L075G	0.071	20.30	54
203L100G	0.095	20.30	54
210L050G	0.049	21.00	56
210L075G	0.074	21.00	56
210L100G	0.098	21.00	56
225L050G	0.053	22.50	60
225L075G	0.079	22.50	60
225L100G	0.111	22.50	60
236L050G*	0.055	23.60	63
236L075G*	0.083	23.60	63
236L100G*	0.111	23.60	63
240L050G	0.056	24.00	64
240L075G	0.084	24.00	64
240L100G	0.113	24.00	64
244L050G*	0.057	24.40	65
244L075G*	0.086	24.40	65
244L100G*	0.114	24.40	65
255L050G	0.060	25.50	68
255L075G	0.090	25.50	68
255L100G	0.120	25.50	68
263L050G	0.062	26.25	70
263L075G	0.093	26.25	70
263L100G	0.123	26.25	70
270L050G	0.063	27.00	72
270L075G	0.095	27.00	72

Belt No.	Wt. Δ (Approx.) Lbs.	Pitch Length (Inches)	No. of Teeth
270L100G	0.127	27.00	72
277L050G	0.065	27.75	74
277L075G	0.097	27.75	74
277L100G	0.130	27.75	74
285L050G	0.067	28.50	76
285L075G	0.100	28.50	76
285L100G	0.134	28.50	76
300L050G	0.070	30.00	80
300L075G	0.106	30.00	80
300L100G	0.141	30.00	80
304L050G	0.071	30.38	81
304L075G	0.107	30.38	81
304L100G	0.143	30.38	81
315L050G	0.074	31.50	84
315L075G	0.111	31.50	84
315L100G	0.148	31.50	84
320L050G	0.075	31.88	85
320L075G	0.113	31.88	85
320L100G	0.150	31.88	85
322L050G	0.076	32.25	86
322L075G	0.113	32.25	86
322L100G	0.151	32.25	86
334L050G	0.078	33.38	89
334L075G	0.117	33.38	89
334L100G	0.157	33.38	89
337L050G	0.079	33.75	90
337L075G	0.119	33.75	90
337L100G	0.158	33.75	90
345L050G	0.081	34.50	92
345L075G	0.121	34.50	92
345L100G	0.162	34.50	92
360L050G	0.084	36.00	96
360L075G	0.127	36.00	96
360L100G	0.169	36.00	96
367L050G	0.086	36.75	98
367L075G	0.129	36.75	98
367L100G	0.172	36.75	98
375L050G	0.088	37.50	100
375L075G	0.132	37.50	100
375L100G	0.176	37.50	100
382L050G	0.090	38.20	102
382L075G	0.134	38.20	102
382L100G	0.179	38.20	102
390L050G	0.091	39.00	104
390L075G	0.137	39.00	104
390L100G	0.183	39.00	104
394L050G	0.092	39.40	105
394L075G	0.139	39.40	105
394L100G	0.185	39.40	105
420L050G	0.098	42.00	112

* Consult IDC-USA for minimum sleeve (quantity) requirements.

Δ Weights shown are approximate and in some cases may be calculated.

For intermediate sizes not shown, consult IDC-USA® for availability and price.

A full range of Synchro-Link® belts are available in single and double-sided configurations in both neoprene and polyurethane construction, RMA and Metric sizes. Consult IDC-USA® for details on your specific requirement.

TIMING BELTS SYNCHRO-LINK®

3/8 Inch Pitch (L) 1/2", 3/4" and 1.0" Wide Belts (Continued)

Belt No.	Wt. Δ (Approx.) Lbs.	Pitch Length (Inches)	No. of Teeth
420L075G	0.148	42.00	112
420L100G	0.197	42.00	112
427L050G	0.100	42.70	114
427L075G	0.150	42.70	114
427L100G	0.200	42.70	114
436L050G	0.102	43.60	116
436L075G	0.153	43.60	116
436L100G	0.204	43.60	116
439L050G	0.103	43.90	117
439L075G	0.154	43.90	117
439L100G	0.206	43.90	117
446L050G	0.105	44.63	119
446L075G	0.157	44.63	119
446L100G	0.209	44.63	119
450L050G	0.106	45.00	120
450L075G	0.158	45.00	120
450L100G	0.211	45.00	120
454L050G*	0.106	45.38	121
454L075G*	0.160	45.38	121
454L100G*	0.213	45.38	121
465L050G	0.109	46.50	124
465L075G	0.164	46.50	124
465L100G	0.218	46.50	124
480L050G	0.113	48.00	128
480L075G	0.169	48.00	128
480L100G	0.225	48.00	128
510L050G	0.120	51.00	136
510L075G	0.179	51.00	136
510L100G	0.239	51.00	136
514L050G	0.121	51.38	137
514L075G	0.181	51.38	137
514L100G	0.241	51.38	137
525L050G	0.123	52.50	140
525L075G	0.185	52.50	140
525L100G	0.246	52.50	140
540L050G	0.127	54.00	144
540L075G	0.190	54.00	144
540L100G	0.253	54.00	144
548L050G	0.129	54.75	146
548L075G	0.193	54.75	146
548L100G	0.257	54.75	146
581L050G	0.136	58.13	155
581L075G	0.204	58.13	155
581L100G	0.272	58.13	155
600L050G	0.141	60.00	160
600L075G	0.211	60.00	160
600L100G	0.281	60.00	160
605L050G	0.142	60.38	161
605L075G	0.213	60.38	161
605L100G	0.284	60.38	161
619L050G	0.145	61.88	165
619L075G	0.218	61.88	165

Belt No.	Wt. Δ (Approx.) Lbs.	Pitch Length (Inches)	No. of Teeth
619L100G	0.290	61.88	165
640L050G	0.150	63.75	170
640L075G	0.225	63.75	170
640L100G	0.300	63.75	170
653L050G	0.153	65.25	174
653L075G	0.230	65.25	174
653L100G	0.306	65.25	174
660L050G	0.155	66.00	176
660L075G	0.232	66.00	176
660L100G	0.310	66.00	176
697L050G	0.163	69.75	186
697L075G	0.245	69.75	186
697L100G	0.327	69.75	186
728L050G	0.171	72.75	194
728L075G	0.256	72.75	194
728L100G	0.341	72.75	194
731L050G	0.171	73.13	195
731L075G	0.257	73.13	195
731L100G	0.343	73.13	195
767L050G	0.180	76.88	205
767L075G	0.270	76.88	205
767L100G	0.360	76.88	205
780L050G	0.183	78.00	208
780L075G	0.274	78.00	208
780L100G	0.366	78.00	208
788L050G	0.185	78.75	210
788L075G	0.277	78.75	210
788L100G	0.370	78.75	210
806L050G	0.189	80.63	215
806L075G	0.284	80.63	215
806L100G	0.378	80.63	215
855L050G	0.200	85.50	228
855L075G	0.301	85.50	228
855L100G	0.401	85.50	228
863L050G	0.202	86.25	230
863L075G	0.304	86.25	230
863L100G	0.405	86.25	230
881L050G	0.207	88.13	235
881L075G	0.310	88.13	235
881L100G	0.413	88.13	235
915L050G	0.215	91.50	244
915L075G	0.322	91.50	244
915L100G	0.429	91.50	244
919L050G	0.216	91.88	245
919L075G	0.323	91.88	245
919L100G	0.431	91.88	245
938L050G	0.220	93.75	250
938L075G	0.330	93.75	250
938L100G	0.440	93.75	250

* Consult IDC-USA® for minimum sleeve (quantity) requirements.

Δ Weights shown are approximate and in some cases may be calculated.

For intermediate sizes not shown, consult IDC-USA® for availability and price.

A full range of Synchro-Link® belts are available in single and double-sided configurations in both neoprene and polyurethane construction, RMA and Metric sizes. Consult IDC-USA® for details on your specific requirement.

TIMING BELTS SYNCHRO-LINK®



BANDO

Nominal Dimensions

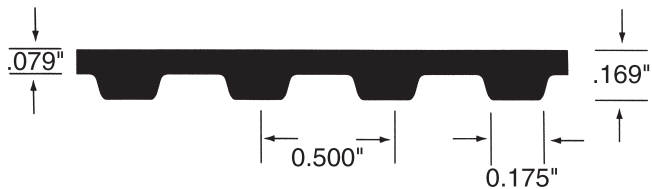

½ Inch Pitch (H) for 1.0", 1½", 2.0" and 3.0" Wide Belts

Belt No.	Wt. Δ (Approx.) Lbs.	Pitch Length (Inches)	No. of Teeth
185H100G	0.107	18.50	37
185H150G	0.161	18.50	37
185H200G	0.215	18.50	37
185H300G	0.322	18.50	37
230H100G	0.133	23.00	46
230H150G	0.200	23.00	46
230H200G	0.267	23.00	46
230H300G	0.400	23.00	46
240H100G	0.139	24.00	48
240H150G	0.209	24.00	48
240H200G	0.278	24.00	48
240H300G	0.418	24.00	48
245H100G	0.142	24.50	49
245H150G	0.213	24.50	49
245H200G	0.284	24.50	49
245H300G	0.426	24.50	49
255H100G	0.148	25.50	51
255H150G	0.222	25.50	51
255H200G	0.296	25.50	51
255H300G	0.444	25.50	51
270H100G	0.157	27.00	54
270H150G	0.235	27.00	54
270H200G	0.313	27.00	54
270H300G	0.470	27.00	54
280H100G	0.162	28.00	56
280H150G	0.244	28.00	56
280H200G	0.325	28.00	56
280H300G	0.487	28.00	56
300H100G	0.174	30.00	60
300H150G	0.261	30.00	60
300H200G	0.348	30.00	60
300H300G	0.522	30.00	60
310H100G	0.180	31.00	62
310H150G	0.270	31.00	62
310H200G	0.360	31.00	62
310H300G	0.539	31.00	62
315H100G	0.183	31.50	63
315H150G	0.274	31.50	63
315H200G	0.365	31.50	63
315H300G	0.548	31.50	63
320H100G	0.186	32.00	64
320H150G	0.278	32.00	64
320H200G	0.371	32.00	64
320H300G	0.557	32.00	64
330H100G	0.191	33.00	66
330H150G	0.287	33.00	66
330H200G	0.383	33.00	66
330H300G	0.574	33.00	66
335H100G*	0.194	33.50	67
335H150G*	0.292	33.50	67
335H200G*	0.389	33.50	67
335H300G*	0.583	33.50	67
340H100G	0.197	34.00	68
340H150G	0.296	34.00	68
340H200G	0.394	34.00	68
340H300G	0.592	34.00	68

Belt No.	Wt. Δ (Approx.) Lbs.	Pitch Length (Inches)	No. of Teeth
350H100G	0.203	35.00	70
350H150G	0.305	35.00	70
350H200G	0.406	35.00	70
350H300G	0.609	35.00	70
360H100G	0.209	36.00	72
360H150G	0.313	36.00	72
360H200G	0.418	36.00	72
360H300G	0.627	36.00	72
370H100G	0.215	37.00	74
370H150G	0.322	37.00	74
370H200G	0.429	37.00	74
370H300G	0.644	37.00	74
375H100G	0.218	37.50	75
375H150G	0.326	37.50	75
375H200G	0.435	37.50	75
375H300G	0.653	37.50	75
390H100G	0.226	39.00	78
390H150G	0.339	39.00	78
390H200G	0.452	39.00	78
390H300G	0.679	39.00	78
400H100G	0.232	40.00	80
400H150G	0.348	40.00	80
400H200G	0.464	40.00	80
400H300G	0.696	40.00	80
410H100G	0.238	41.00	82
410H150G	0.357	41.00	82
410H200G	0.476	41.00	82
410H300G	0.714	41.00	82
420H100G	0.244	42.00	84
420H150G	0.365	42.00	84
420H200G	0.487	42.00	84
420H300G	0.731	42.00	84
430H100G	0.249	43.00	86
430H150G	0.374	43.00	86
430H200G	0.499	43.00	86
430H300G	0.748	43.00	86
450H100G	0.261	45.00	90
450H150G	0.392	45.00	90
450H200G	0.522	45.00	90
450H300G	0.783	45.00	90
465H100G	0.270	46.50	93
465H150G	0.405	46.50	93
465H200G	0.539	46.50	93
465H300G	0.809	46.50	93
480H100G	0.278	48.00	96
480H150G	0.418	48.00	96
480H200G	0.557	48.00	96
480H300G	0.835	48.00	96
490H100G	0.284	49.00	98
490H150G	0.426	49.00	98
490H200G	0.568	49.00	98
490H300G	0.853	49.00	98
510H100G	0.296	51.00	102
510H150G	0.444	51.00	102
510H200G	0.592	51.00	102
510H300G	0.888	51.00	102

Δ Weights shown are approximate and in some cases may be calculated.

For intermediate sizes not shown, consult IDC-USA® for availability and price.

A full range of Synchro-Link® belts are available in single and double-sided configurations in both neoprene and polyurethane construction, RMA and Metric sizes. Consult IDC-USA® for details on your specific requirement.

* Consult IDC-USA® for minimum sleeve (quantity) requirements.

TIMING BELTS SYNCHRO-LINK®

½ Inch Pitch (H) for 1.0", 1½", 2.0" and 3.0" Wide Belts (Continued)

Belt No.	Wt. Δ (Approx.) Lbs.	Pitch Length (Inches)	No. of Teeth
530H100G	0.307	53.00	106
530H150G	0.461	53.00	106
530H200G	0.615	53.00	106
530H300G	0.922	53.00	106
540H100G	0.313	54.00	108
540H150G	0.470	54.00	108
540H200G	0.627	54.00	108
540H300G	0.940	54.00	108
560H100G	0.325	56.00	112
560H150G	0.487	56.00	112
560H200G	0.650	56.00	112
560H300G	0.975	56.00	112
570H100G	0.331	57.00	114
570H150G	0.496	57.00	114
570H200G	0.661	57.00	114
570H300G	0.992	57.00	114
580H100G	0.336	58.00	116
580H150G	0.505	58.00	116
580H200G	0.673	58.00	116
580H300G	1.009	58.00	116
600H100G	0.348	60.00	120
600H150G	0.522	60.00	120
600H200G	0.696	60.00	120
600H300G	1.044	60.00	120
605H100G	0.351	60.50	121
605H150G	0.526	60.50	121
605H200G	0.702	60.50	121
605H300G	1.053	60.50	121
630H100G	0.365	63.00	126
630H150G	0.548	63.00	126
630H200G	0.731	63.00	126
630H300G	1.096	63.00	126
650H100G	0.377	65.00	130
650H150G	0.566	65.00	130
650H200G	0.754	65.00	130
650H300G	1.131	65.00	130
660H100G	0.383	66.00	132
660H150G	0.574	66.00	132
660H200G	0.766	66.00	132
660H300G	1.149	66.00	132
680H100G	0.394	68.00	136
680H150G	0.592	68.00	136
680H200G	0.789	68.00	136
680H300G	1.183	68.00	136
700H100G	0.406	70.00	140
700H150G	0.609	70.00	140
700H200G	0.812	70.00	140
700H300G	1.218	70.00	140
730H100G	0.423	73.00	146
730H150G	0.635	73.00	146
730H200G	0.847	73.00	146
730H300G	1.270	73.00	146
750H100G	0.435	75.00	150
750H150G	0.653	75.00	150
750H200G	0.870	75.00	150
750H300G	1.305	75.00	150
760H100G	0.441	76.00	152
760H150G	0.661	76.00	152
760H200G	0.882	76.00	152
760H300G	1.323	76.00	152
770H100G	0.447	77.00	154
770H150G	0.670	77.00	154
770H200G	0.893	77.00	154
770H300G	1.340	77.00	154
800H100G	0.464	80.00	160
800H150G	0.696	80.00	160
800H200G	0.928	80.00	160
800H300G	1.392	80.00	160
810H100G	0.470	81.00	162
810H150G	0.705	81.00	162
810H200G	0.940	81.00	162
810H300G	1.410	81.00	162

Belt No.	Wt. Δ (Approx.) Lbs.	Pitch Length (Inches)	No. of Teeth
820H100G	0.476	82.00	164
820H150G	0.714	82.00	164
820H200G	0.951	82.00	164
820H300G	1.427	82.00	164
840H100G	0.487	84.00	168
840H150G	0.731	84.00	168
840H200G	0.975	84.00	168
840H300G	1.462	84.00	168
850H100G	0.493	85.00	170
850H150G	0.740	85.00	170
850H200G	0.986	85.00	170
850H300G	1.479	85.00	170
860H100G	0.499	86.00	172
860H150G	0.748	86.00	172
860H200G	0.998	86.00	172
860H300G	1.497	86.00	172
880H100G	0.510	88.00	176
880H150G	0.766	88.00	176
880H200G	1.021	88.00	176
880H300G	1.531	88.00	176
900H100G	0.522	90.00	180
900H150G	0.783	90.00	180
900H200G	1.044	90.00	180
900H300G	1.566	90.00	180
950H100G	0.551	95.00	190
950H150G	0.827	95.00	190
950H200G	1.102	95.00	190
950H300G	1.653	95.00	190
985H100G	0.571	98.50	197
985H150G	0.857	98.50	197
985H200G	1.143	98.50	197
985H300G	1.714	98.50	197
1000H100G	0.580	100.00	200
1000H150G	0.870	100.00	200
1000H200G	1.160	100.00	200
1000H300G	1.740	100.00	200
1020H100G	0.592	102.00	204
1020H150G	0.888	102.00	204
1020H200G	1.183	102.00	204
1020H300G	1.775	102.00	204
1050H100G	0.609	105.00	210
1050H150G	0.914	105.00	210
1050H200G	1.218	105.00	210
1050H300G	1.827	105.00	210
1100H100G	0.638	110.00	220
1100H150G	0.957	110.00	220
1100H200G	1.276	110.00	220
1100H300G	1.914	110.00	220
1140H100G	0.661	114.00	228
1140H150G	0.992	114.00	228
1140H200G	1.323	114.00	228
1140H300G	1.984	114.00	228
1250H100G	0.725	125.00	250
1250H150G	1.088	125.00	250
1250H200G	1.450	125.00	250
1250H300G	2.175	125.00	250
1325H100G*	0.769	132.50	265
1325H150G*	1.153	132.50	265
1325H200G*	1.537	132.50	265
1325H300G*	2.306	132.50	265
1350H100G	0.783	135.00	270
1350H150G	1.175	135.00	270
1350H200G	1.566	135.00	270
1350H300G	2.349	135.00	270
1400H100G	0.812	140.00	280
1400H150G	1.218	140.00	280
1400H200G	1.624	140.00	280
1400H300G	2.436	140.00	280
1700H100G	0.986	170.00	340
1700H150G	1.479	170.00	340
1700H200G	1.972	170.00	340
1700H300G	2.959	170.00	340

Δ Weights shown are approximate and in some cases may be calculated.

For intermediate sizes not shown, consult IDC-USA® for availability and price.

A full range of Synchro-Link® belts are available in single and double-sided configurations in both neoprene and polyurethane construction, RMA and Metric sizes. Consult IDC-USA® for details on your specific requirement.

* Consult IDC-USA® for minimum sleeve (quantity) requirements.

TIMING BELTS SYNCHRO-LINK® METRIC

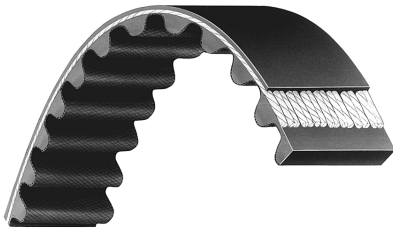

BANDO

Nominal Dimensions

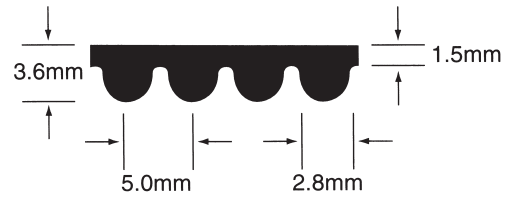

5MM Pitch (HT) for 9MM, 15MM and 25MM Wide Belts

Belt No.	Wt. Δ (Approx.) Lbs.	Pitch Length (MM)	No. of Teeth
265-5M-9 H	0.1700	265	53
265-5M-15 H	0.2830	265	53
265-5M-25 H	0.4720	265	53
295-5M-9 H	0.1890	295	59
295-5M-15 H	0.3150	295	59
295-5M-25 H	0.5250	295	59
300-5M-8 H	0.0192	300	60
300-5M-15 H	0.0320	300	60
1300-5M-25 H	0.0534	300	60
330-5M-9 H	0.0211	330	66
330-5M-15 H	0.0352	330	66
330-5M-25 H	0.0587	330	66
350-5M-9 H	0.0224	350	70
350-5M-15 H	0.0374	350	70
350-5M-25 H	0.0623	350	70
375-5M-9 H	0.0240	375	75
375-5M-15 H	0.0401	375	75
375-5M-25 H	0.0668	375	75
400-5M-9 H	0.0256	400	80
400-5M-15 H	0.0427	400	80
400-5M-25 H	0.0712	400	80
425-5M-9 H	0.0272	425	85
425-5M-15 H	0.0454	425	85
425-5M-25 H	0.0757	425	85
450-5M-9 H	0.0288	450	90
450-5M-15 H	0.0481	450	90
450-5M-25 H	0.0801	450	90
460-5M-9 H	0.0295	460	92
460-5M-15 H	0.0491	460	92
460-5M-25 H	0.0819	460	92
475-5M-9 H	0.0304	475	95
475-5M-15 H	0.0507	475	95
475-5M-25 H	0.0846	475	95
500-5M-9 H	0.0320	500	100
500-5M-15 H	0.0534	500	100
500-5M-25 H	0.0890	500	100
535-5M-9 H	0.0343	535	107
535-5M-15 H	0.0571	535	107
535-5M-25 H	0.0952	535	107
565-5M-9 H	0.0362	565	113
565-5M-15 H	0.0604	565	113
565-5M-25 H	0.1006	565	113
600-5M-9 H	0.0385	600	120
600-5M-15 H	0.0641	600	120
600-5M-25 H	0.1068	600	120
615-5M-9 H	0.0394	615	123
615-5M-15 H	0.0657	615	123
615-5M-25 H	0.1095	615	123
620-5M-9 H	0.0397	620	124
620-5M-15 H	0.0662	620	124

Belt No.	Wt. Δ (Approx.) Lbs.	Pitch Length (MM)	No. of Teeth
620-5M-25 H	0.1104	620	124
630-5M-9 H	0.0404	630	126
630-5M-15 H	0.0673	630	126
630-5M-25 H	0.1122	630	126
635-5M-9 H	0.0407	635	127
635-5M-15 H	0.0678	635	127
635-5M-25 H	0.1130	635	127
665-5M-9 H	0.0426	665	133
665-5M-15 H	0.0710	665	133
665-5M-25 H	0.1184	665	133
710-5M-9 H	0.0455	710	142
710-5M-15 H	0.0758	710	142
710-5M-25 H	0.1264	710	142
740-5M-9 H	0.0474	740	148
740-5M-15 H	0.0790	740	148
740-5M-25 H	0.1317	740	148
755-5M-9 H	0.0484	755	151
755-5M-15 H	0.0806	755	151
755-5M-25 H	0.1344	755	151
800-5M-9 H	0.0513	800	160
800-5M-15 H	0.0855	800	160
800-5M-25 H	0.1424	800	160
835-5M-9 H	0.0535	835	167
835-5M-15 H	0.0892	835	167
835-5M-25 H	0.1487	835	167
890-5M-9 H	0.0570	890	178
890-5M-15 H	0.0951	890	178
890-5M-25 H	0.1584	890	178
900-5M-9 H	0.0577	900	180
900-5M-15 H	0.0961	900	180
900-5M-25 H	0.1602	900	180
925-5M-9 H	0.0593	925	185
925-5M-15 H	0.0988	925	185
925-5M-25 H	0.1647	925	185
1000-5M-9 H	0.0641	1000	200
1000-5M-15 H	0.1068	1000	200
1000-5M-25 H	0.1780	1000	200
1050-5M-9 H	0.0673	1050	210
1050-5M-15 H	0.1122	1050	210
1050-5M-25 H	0.1869	1050	210
1125-5M-9 H	0.0721	1125	225
1125-5M-15 H	0.1202	1125	225
1125-5M-25 H	0.2003	1125	225
1270-5M-9 H	0.0814	1270	254
1270-5M-15 H	0.1357	1270	254
1270-5M-25 H	0.2261	1270	254
1500-5M-9 H	0.0961	1500	300
1500-5M-15 H	0.1602	1500	300
1500-5M-25 H	0.2670	1500	300

Δ Weights shown are approximate and in some cases may be calculated.
 For intermediate sizes not shown, consult IDC-USA® for availability and price.
 Some specific sizes of 5MM Synchro-Link® HT may require minimum order quantities.
 Consult IDC-USA® when ordering.

TIMING BELTS SYNCHRO-LINK® METRIC

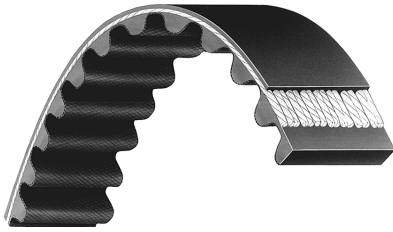

BANDO

Nominal Dimensions

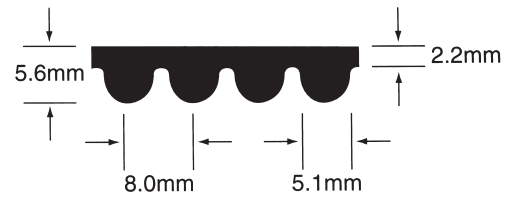

8MM Pitch (HT) for 20MM, 30MM, 50MM and 85MM Wide Belts

Belt No.	Wt. Δ (Approx.) Lbs.	Pitch Length (MM)	No. of Teeth
376-8M-20 H*	0.091	376	47
376-8M-30 H*	0.136	376	47
376-8M-50 H*	0.227	376	47
376-8M-85 H*	0.386	376	47
424-8M-20 H*	0.102	424	53
424-8M-30 H*	0.154	424	53
424-8M-50 H*	0.256	424	53
424-8M-85 H*	0.435	424	53
480-8M-20 H	0.116	480	60
480-8M-30 H	0.174	480	60
480-8M-50 H	0.290	480	60
480-8M-85 H	0.493	480	60
560-8M-20 H	0.135	560	70
560-8M-30 H	0.203	560	70
560-8M-50 H	0.338	560	70
560-8M-85 H	0.575	560	70
600-8M-20 H	0.145	600	75
600-8M-30 H	0.217	600	75
600-8M-50 H	0.362	600	75
600-8M-85 H	0.616	600	75
624-8M-20 H*	0.151	624	78
624-8M-30 H*	0.226	624	78
624-8M-50 H*	0.377	624	78
624-8M-85 H*	0.641	624	78
640-8M-20 H	0.155	640	80
640-8M-30 H	0.232	640	80
640-8M-50 H	0.387	640	80
640-8M-85 H	0.657	640	80
720-8M-20 H	0.174	720	90
720-8M-30 H	0.261	720	90
720-8M-50 H	0.435	720	90
720-8M-85 H	0.739	720	90
776-8M-20 H*	0.187	776	97
776-8M-30 H*	0.281	776	97
776-8M-50 H*	0.469	776	97
776-8M-85 H*	0.797	776	97
784-8M-20 H*	0.189	784	98
784-8M-30 H*	0.284	784	98
784-8M-50 H*	0.474	784	98
784-8M-85 H*	0.805	784	98
800-8M-20 H	0.193	800	100
800-8M-30 H	0.290	800	100
800-8M-50 H	0.483	800	100
800-8M-85 H	0.821	800	100
880-8M-20 H	0.213	880	110
880-8M-30 H	0.319	880	110
880-8M-50 H	0.532	880	110
880-8M-85 H	0.904	880	110
912-8M-20 H*	0.220	912	114
912-8M-30 H*	0.331	912	114
912-8M-50 H*	0.551	912	114
912-8M-85 H*	0.936	912	114
920-8M-20 H*	0.222	920	115
920-8M-30 H*	0.333	920	115
920-8M-50 H*	0.556	920	115

Belt No.	Wt. Δ (Approx.) Lbs.	Pitch Length (MM)	No. of Teeth
920-8M-85 H*	0.945	920	115
960-8M-20 H	0.232	960	120
960-8M-30 H	0.348	960	120
960-8M-50 H	0.580	960	120
960-8M-85 H	0.986	960	120
1040-8M-20 H	0.251	1040	130
1040-8M-30 H	0.377	1040	130
1040-8M-50 H	0.628	1040	130
1040-8M-85 H	1.068	1040	130
1120-8M-20 H	0.271	1120	140
1120-8M-30 H	0.406	1120	140
1120-8M-50 H	0.676	1120	140
1120-8M-85 H	1.150	1120	140
1200-8M-20 H	0.290	1200	150
1200-8M-30 H	0.435	1200	150
1200-8M-50 H	0.725	1200	150
1200-8M-85 H	1.232	1200	150
1280-8M-20 H	0.309	1280	160
1280-8M-30 H	0.464	1280	160
1280-8M-50 H	0.773	1280	160
1280-8M-85 H	1.314	1280	160
1304-8M-20 H*	0.315	1304	163
1304-8M-30 H*	0.483	1304	163
1304-8M-50 H*	0.788	1304	163
1304-8M-85 H*	1.339	1304	163
1360-8M-20 H*	0.329	1360	170
1360-8M-30 H*	0.493	1360	170
1360-8M-50 H*	0.821	1360	170
1360-8M-85 H*	1.396	1360	170
1424-8M-20 H*	0.344	1424	178
1424-8M-30 H*	0.516	1424	178
1424-8M-50 H*	0.860	1424	178
1424-8M-85 H*	1.462	1424	178
1440-8M-20 H	0.348	1440	180
1440-8M-30 H	0.522	1440	180
1440-8M-50 H	0.870	1440	180
1440-8M-85 H	1.479	1440	180
1600-8M-20 H	0.387	1600	200
1600-8M-30 H	0.580	1600	200
1600-8M-50 H	0.966	1600	200
1600-8M-85 H	1.643	1600	200
1760-8M-20 H	0.425	1760	220
1760-8M-30 H	0.638	1760	220
1760-8M-50 H	1.063	1760	220
1760-8M-85 H	1.807	1760	220
1800-8M-20 H	0.435	1800	225
1800-8M-30 H	0.652	1800	225
1800-8M-50 H	1.087	1800	225
1800-8M-85 H	1.848	1800	225
2000-8M-20 H	0.483	2000	250
2000-8M-30 H	0.725	2000	250
2000-8M-50 H	1.208	2000	250
2000-8M-85 H	2.054	2000	250
2248-8M-20 H*	0.543	2248	281
2248-8M-30 H*	0.815	2248	281

* Consult IDC-USA® for minimum sleeve (quantity) requirements.

Δ Weights shown are approximate and in some cases may be calculated.

For intermediate sizes not shown, consult IDC-USA® for availability and price.

A full range of Synchro-Link® belts are available in single and double-sided configurations in both neoprene and polyurethane construction, RMA and Metric sizes. Consult IDC-USA® for details on your specific requirement.

TIMING BELTS SYNCHRO-LINK® METRIC

8MM Pitch (HT) for 20MM, 30MM, 50MM and 85MM Wide Belts (Continued)

Belt No.	Wt. Δ (Approx.) Lbs.	Pitch Length (MM)	No. of Teeth
2248-8M-50 H*	1.358	2248	281
2248-8M-85 H*	2.308	2248	281
2400-8M-20 H	0.580	2400	300
2400-8M-30 H	0.870	2400	300
2400-8M-50 H	1.450	2400	300
2400-8M-85 H	2.464	2400	300
2600-8M-20 H	0.628	2600	325
2600-8M-30 H	0.942	2600	325
2600-8M-50 H	1.570	2600	325
2600-8M-85 H	2.670	2600	325
2800-8M-20 H	0.676	2800	350
2800-8M-30 H	1.015	2800	350
2800-8M-50 H	1.691	2800	350
2800-8M-85 H	2.875	2800	350
3048-8M-20 H*	0.736	3048	381

Belt No.	Wt. Δ (Approx.) Lbs.	Pitch Length (MM)	No. of Teeth
3048-8M-30 H*	1.105	3048	381
3048-8M-50 H*	1.841	3048	381
3048-8M-85 H*	3.130	3048	381
3280-8M-20 H*	0.792	3280	410
3280-8M-30 H*	1.189	3280	410
3280-8M-50 H*	1.981	3280	410
3280-8M-85 H*	3.368	3280	410
3600-8M-20 H*	0.870	3600	450
3600-8M-30 H*	1.305	3600	450
3600-8M-50 H*	2.174	3600	450
3600-8M-85 H*	3.696	3600	450
4400-8M-20 H*	1.063	4400	550
4400-8M-30 H*	1.595	4400	550
4400-8M-50 H*	2.658	4400	550
4400-8M-85 H*	4.518	4400	550

* Consult IDC-USA® for minimum sleeve (quantity) requirements.

Δ Weights shown are approximate and in some cases may be calculated.
For intermediate sizes not shown, consult IDC-USA® for availability and price.

In addition to the single sided HT belts shown on pages 74 through 76
Bando makes available the most popular sizes of double sided 3M, 5M and 8M.
Consult IDC-USA® for availability and price.